

HITACHI REGULATORS

LUV
Subaru

DESCRIPTION

The regulator system consists basically of a voltage regulator and a charge relay. The voltage regulator has two sets of contact points, a lower set and upper set, to control alternator voltage. An armature plate placed between the two sets of contacts moves upward, downward, or vibrates. The lower contacts, when closed, complete the field circuit direct to ground. The upper contacts, when closed, complete field circuit to ground through a resistance (field coil), and thereby produces alternator output. The charge relay is similar in construction to voltage regulator. When upper contacts are closed, ignition warning lamp goes on.

APPLICATION

Model	Hitachi No.
LUV	TLIZ-87
Subaru	TLIZ-94

TESTING

VOLTAGE REGULATOR

1) Connect voltmeter and ammeter as illustrated. Start and maintain engine speed at 2500 RPM for a few minutes, then check to make sure that reading of ammeter is 5 amps or less. If ammeter remains higher than 5 amps, disconnect battery in use and connect a battery known to be fully charged. Recheck to be sure reading of ammeter is lower than 5 amps.

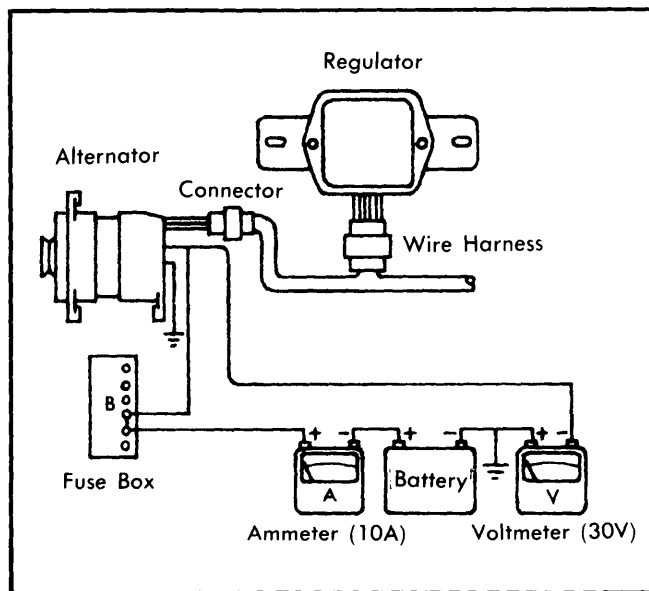

Fig. 1 Test Connections for Voltage Regulator

2) Lower engine speed to idle and again increase it gradually to 2500 RPM, then note voltmeter reading. Function of regulator is normal if measured value is within specified regulating voltage. If reading of voltmeter deviates from specified range, it indicates regulator is in need of adjustment.

ADJUSTMENT

NOTE — Charge relay is adjusted in same manner as voltage regulator.

1) Disconnect and remove voltage regulator from vehicle. If contact points are roughened, smooth with fine sand paper. Check and adjust gaps: core gap first, then point gap. **NOTE** — Adjustment of yoke gap is unnecessary on some models.

2) Adjust core gap by loosening screws attaching contact set to yoke. Move contact set upward or downward as required. Adjust point gap by loosening screw attaching upper contact. Move upper contact up or down as required to set gap to specification.

3) Adjust regulated voltage by means of adjusting screw. Turn screw in to increase regulated voltage or out to decrease voltage. When correct voltage adjustment is obtained, secure with lock nut. When adjustment procedure is complete, reinstall regulator and perform on car check.

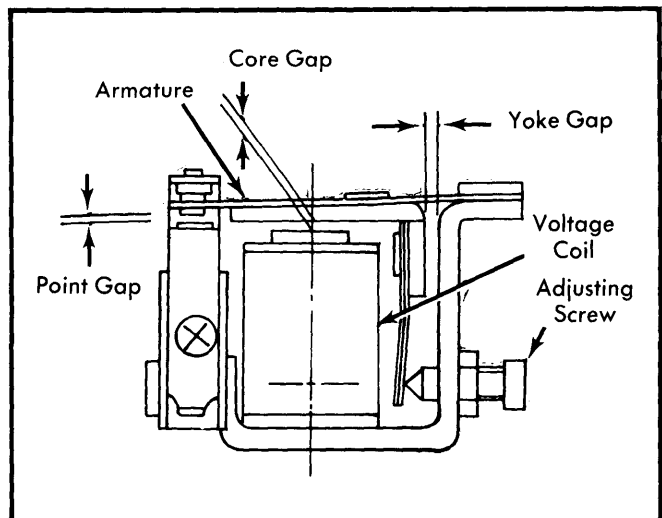

Fig. 2 Adjustment Points for Charge Relay

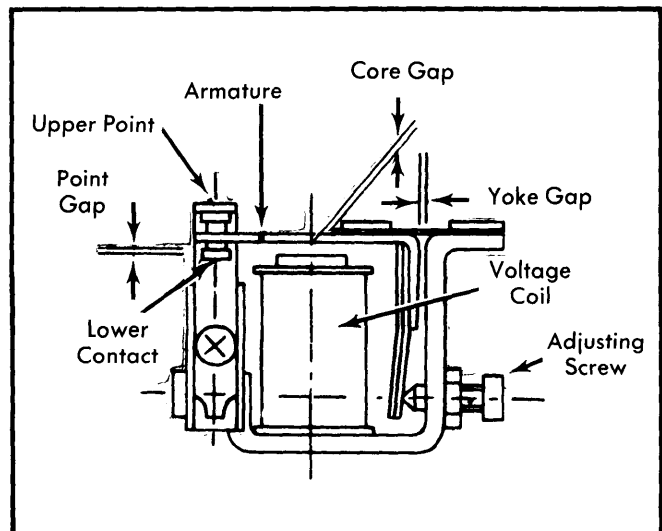

Fig. 3 Adjustment Points for Voltage Regulator

Alternators & Regulators

HITACHI REGULATORS (Cont.)

VOLTAGE REGULATOR SPECIFICATIONS						
Regulator	Battery Voltage	Regulated Voltage	Voltage Coil Resistance (Ohms)	Yoke Gap In. (mm)	Core Gap In. (mm)	Point Gap In. (mm)
TLIZ-87	12	13.8-14.8	10.3	①	.024-.039(.6-1.0)	.012-.016(.3-.4)
TLIZ-94	12	14.0-15.0	10.3	.035(.9)	.024-.039(.6-1.0)	.012-.016(.3-.4)

① — No yoke gap adjustment required.

VOLTAGE RELAY SPECIFICATIONS					
Regulator	Released Voltage	Voltage Coil Resistance (Ohms)	Yoke Gap In. (mm)	Core Gap In. (mm)	Point Gap In. (mm)
TLIZ-87	5②	31.9	①	.032-.039(.8-1.0)	.016-.024(.41-.61)
TLIZ-94	8-10	31.9	.035(.9)	.032-.039(.8-1.0)	.016-.024(.41-.61)

① — No yoke gap adjustment required.

② — Measured at "A" terminal.