

HITACHI & MITSUBISHI

Arrow
Colt
Datsun
Honda
LUV
Mazda
Opel

Mitsubishi

DESCRIPTION

Starter is a 12-volt, four-pole unit of conventional design. Magnetic switch assembly is mounted on gear case. Starters have a overrunning clutch connected by a shift lever to magnetic switch plunger. Brushes and springs are retained inside yoke assembly by holders.

APPLICATION

Hitachi

Model	Part No.
Datsun	
B210	
Man. Trans.	S114-160B
Auto. Trans.	S114-163B
F10	
Man. Trans.	S114-161B
Auto. Trans.	S114-208B
200SX, 710 & P/U 620	
Man. Trans.	S114-170B
Auto. Trans.	S114-180B
810, 280Z	
Man. Trans.	S114-173B
Auto. Trans.	S114-182B
LUV	
.....	S114-202
Honda	
Civic	31200 657 671
Opel	94204338

Model	Part No.
Arrow & Colt	
1600cc	
Man. Trans.	M3T12572
Auto. Trans.	M3T15772
2000cc	
Man. Trans.	M3T15772
Auto. Trans.	M4T14771
Mazda	
1300cc	0324 18 400A
1600cc	0426 18 400A
RX-3 Auto. Trans.	1883 18 400
All Others	
Man. Trans.	1757 18 400C
Auto. Trans.	1758 18 400C

TESTING

PERFORMANCE TESTS

No Load Tests – Connect starter in series with a 12 volt battery, being certain ammeter used is capable of 1000 ampere reading. Connect voltmeter to starter (see illustration). Compare readings with specifications.

Lock (Torque) Test – Mount starter in a test stand to allow starter torque measurement (follow manufacturers instructions). With voltage adjusted (see specifications), ammeter reading and starter torque should be within specifications.

STARTER PERFORMANCE SPECIFICATIONS

Model	No Load Test		Lock Test		
	Amps.	RPM	Amps.	Volts	Torque
HITACHI					
S114-160B	below 60	7000
S114-161B	below 60	7000
S114-163B	below 60	7000
S114-170B	below 60	7000
S114-173B	below 60	6000
S114-180B	below 60	6000
S114-182B	below 60	6000
S114-202B	below 60	6000	below 330	5.0	over 5.8 ft.lbs.
S114-208B	below 60	7000
31200-657-671 ^①	below 70	7000	below 380	4.9	over 5.4 ft.lbs.
94204338 ^②
MITSUBISHI					
M3T12572	below 53	5000	below 400	6.0	6.7 ft.lbs.
M3T15772	below 55	6500	below 560	6.0	10.8 ft.lbs.
M4T14771	below 62	4500	below 730	6.0	18.0 ft.lbs.
0324 18 400A	below 53	5000	below 400	6.0	6.7 ft.lbs.
0426 18 400A	below 53	5000	below 400	6.0	6.7 ft.lbs.
1757 18 400C	above 75	4900	below 780	5.0	8.0 ft.lbs.
1758 18 400C	below 100	7800	below 1100	5.0	17.4 ft.lbs.
1883 18 400C	below 100	7800	below 1100	5.0	17.4 ft.lbs.

① – Honda part number.
② – Buick part number.

HITACHI & MITSUBISHI (Cont.)

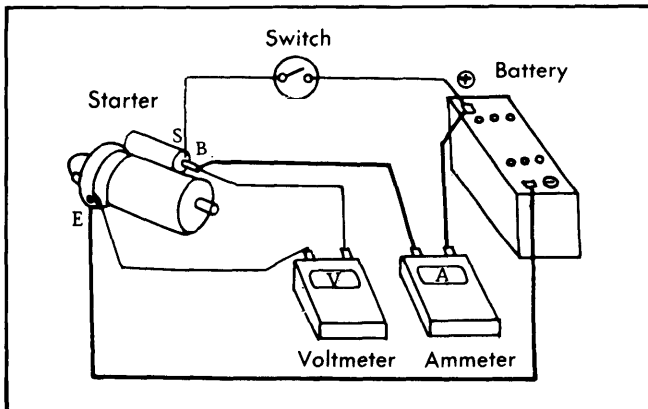

Fig. 1 Connections for No Load Test

OVERHAUL

DISASSEMBLY

- 1) Loosen nut securing connecting plate to magnetic switch "M" terminal, remove screws securing magnetic switch and remove switch assembly. Remove two through bolts and brush cover assembly, then tap yoke assembly with a wooden hammer and remove it. Remove armature assembly shift lever.
- 2) Remove pinion stop ring from end of armature shaft by pushing stop ring to the clutch side. Remove snap ring and then remove stop ring with overrunning clutch. Remove overrunning clutch assembly from armature shaft.

PARTS REPLACEMENT & TESTING

Brushes & Springs — Check brush spring tension using a suitable spring scale (see specifications). Check brush contact surface condition. If brush contact is loose, replace brush. If brush length is less than specified, replace brushes. Check lead clip and wire connection, check condition of brush holders and spring clip, repair or replace parts as necessary.

Brush Spring Tension

Application	Lbs. (Kg)
Arrow, Colt	3.3 (1.5)
Datsun	3.1-4.0 (1.4-1.8)
Honda, LUV, Mazda, Opel	3.5 (1.6)

Brush Length (Minimum)

Application	In. (mm)
Arrow, Colt, Mazda	.45 (11.5)
Datsun	.47 (12.0)
Honda	.16 (4.0)
LUV, Opel	.47 (12.0)

Armature — Check external condition of armature. Measure shaft for distortion or bending, using a dial indicator gauge. Replace armature shaft if bending exceeds .0031" on Datsun, .006" on Luv and .004" on all other models.

Commutator — Inspect commutator for roughness, if surface is pitted or grooved, it should be sanded lightly with no. 500 emery paper. Also check commutator for being out-of-round. If out-of-round is more than .0079", or insulating mica depth is less than .0079" from the commutator surface, turn commutator in a lathe until out-of-round is less than .002". Insulating mica should be undercut to depth of .0197-.0315". Wear limit of commutator diameter is .0787", if excessively worn, it must be replaced.

Field Coil — Check field coil continuity by connecting test probe of a circuit tester or a resistance counter to the field coil positive terminal and positive brush holder, if tester shows no continuity, field circuit or coil is open. Check for grounded field coils by placing one probe of a circuit tester on yoke and other probe to field coil positive terminal, if resistance is read, field coils are grounded.

Overrunning Clutch Assembly — Inspect pinion assembly and sleeve. Sleeve should slide freely along armature shaft spline and if damage or resistance is noted, replace assembly. Inspect pinion teeth for excessive rubbing, replace as necessary. Check flywheel ring gear for damage or wear.

Magnetic Switch Assembly — After checking starter motor, magnetic switch assembly should also be checked. Connect jumper cables between negative battery terminal and starting motor "M" terminal, and positive battery terminal and starting motor "S" terminal, connecting ignition switch in series (see illustration). With ignition switch on, measure distance between the pinion front edge and pinion stopper (see illustration). Clearance should be .012-.059" on Hitachi starters and .02-.08" on Mitsubishi starters. If not within specifications, adjust by changing washer between magnetic switch and gear case.

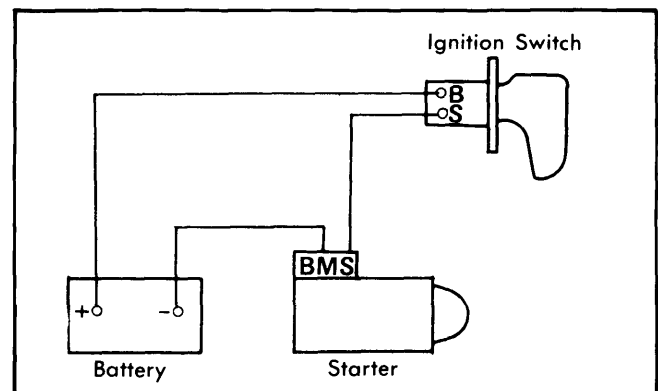

Fig. 2 Circuit for Testing Magnetic Switch Assembly

Pinion Case Bearing — Inspect bearing for wear and check side play. Clearance between bearing and armature shaft should not exceed .0079". If limit is exceeded, replace bearing. Clearance with new bearing installed should be .001-.004" on Hitachi starters and .002-.004" on Mitsubishi starters.

NOTE — Be sure bearing is installed so that end of bearing is flush with gear case end plane.

HITACHI & MITSUBISHI (Cont.)

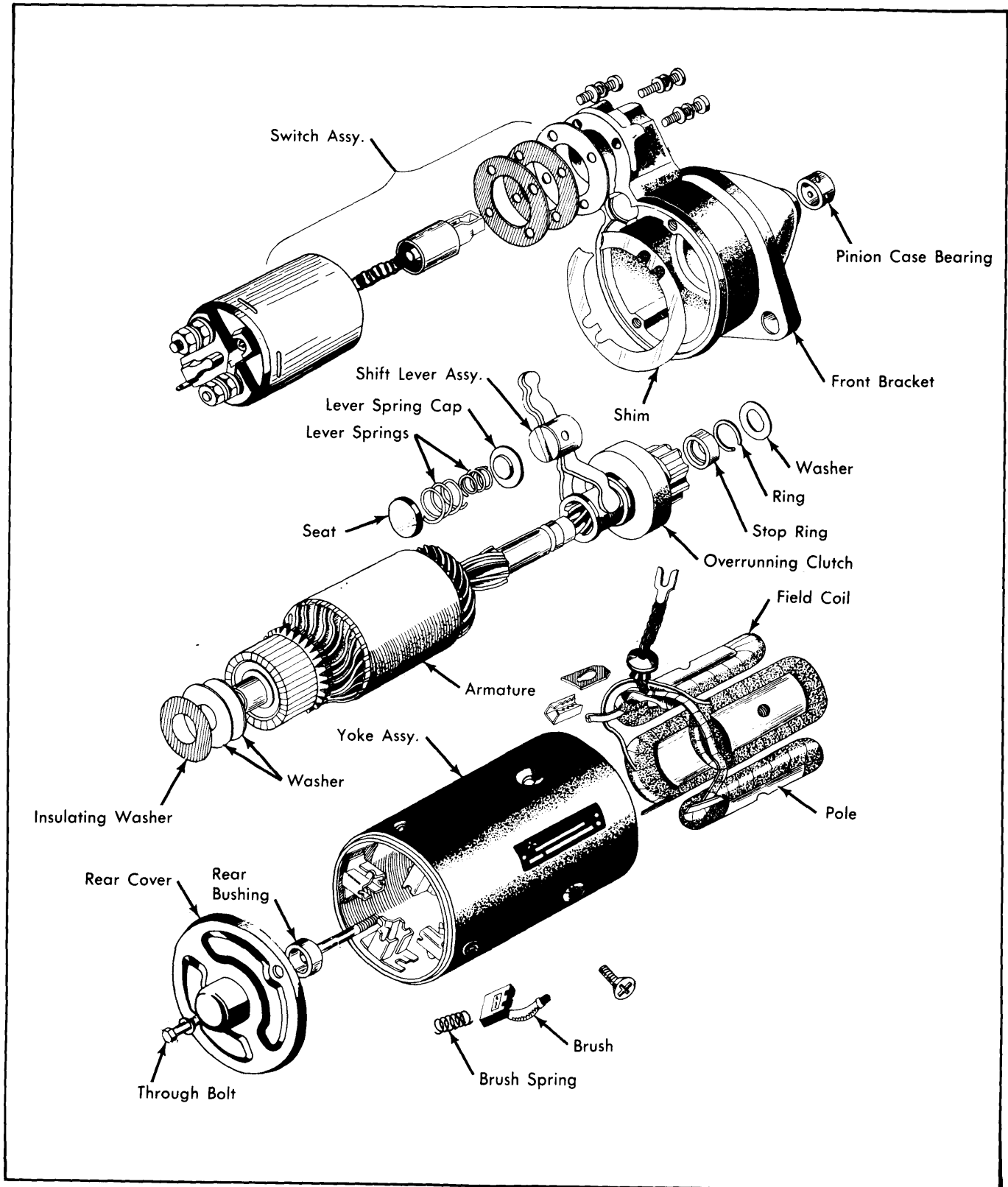

Fig. 3 Disassembled View of a Typical Mitsubishi Starter

Starters

HITACHI & MITSUBISHI (Cont.)

CLEANING & INSPECTION

Clean all disassembled parts, being careful not to use a grease dissolving solvent on overrunning clutch, armature assembly, magnetic switch assembly or field coils, as damage could result. Check all parts for damage or excessive wear, replace as required.

REASSEMBLY

To reassemble, reverse disassembly procedure and be certain to fill rear case with grease and to lightly oil rear cover metal bearing and pinion.

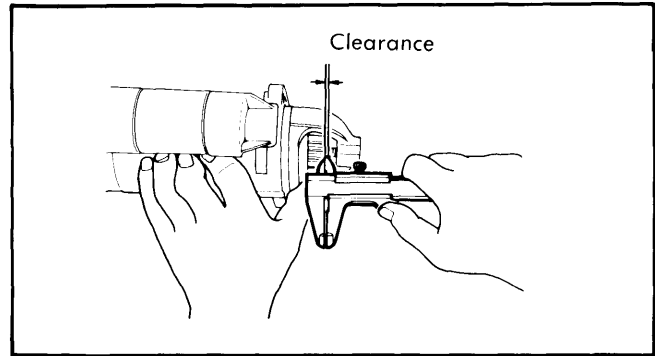

Fig. 4 Measuring Pinion Edge-to-Pinion Stopper Clearance

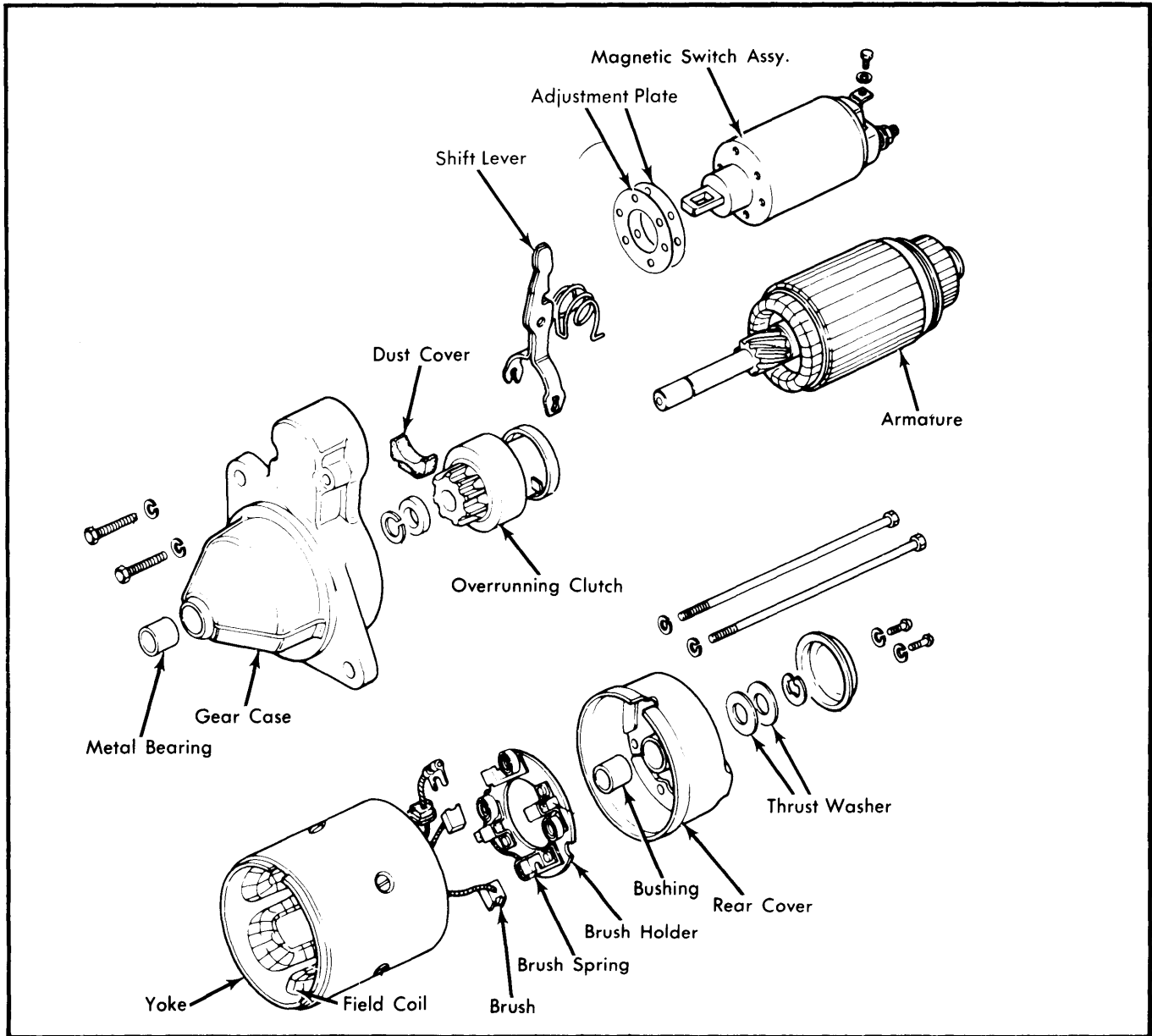

Fig. 5 Disassembled View of a Typical Hitachi Starter