

SEV MOTOROLA REGULATORS

Porsche

APPLICATION

► CHANGES, CAUTIONS, CORRECTIONS

► **SERVICE CAUTION** — When servicing alternator or regulator, note following precautions to avoid damage to components:

Field Terminal — Never ground field energizing terminal on alternator, regulator or connecting lead.

Voltage Regulator — Never operate voltage regulator without a good ground connection. Immediate damage will result.

Alternator — Do not ground output terminal. Always disconnect battery negative cable before removing wire from alternator output terminal. Do not attempt to polarize alternator as polarization is not required and any attempt to polarize will damage voltage regulator and wiring harness.

DESCRIPTION

SEV Motorola alternators use either an electronic or mechanical type voltage regulator. The electronic unit contains neither mechanical contacts or relays, and requires no adjustments or maintenance. It is sealed, and if found to be defective requires replacement. The mechanical voltage regulator has fixed upper and lower contacts and the center contact is moveable.

Model

Part No.

Porsche
911 & Carrera 911 603 90100

TESTING

ON CAR TEST

- 1) Connect alternator and regulator as shown in illustration. For an accurate test, drive vehicle or operate system (on bench) for about 45 minutes at 30 miles per hour or more. This will allow regulator to reach its normal operating temperature.
- 2) Run alternator at 5000 RPM (engine speed at 2500 RPM) for 15 seconds. Voltage with no load should be as shown in specifications.
- 3) Load alternator with 10-15 amperes (for example, high beam headlights). Record voltage reading. The voltage should also be as shown in specifications.
- 4) The following chart gives voltage values for other ambient temperatures. If voltage is outside tolerance limits, regulator must be replaced.

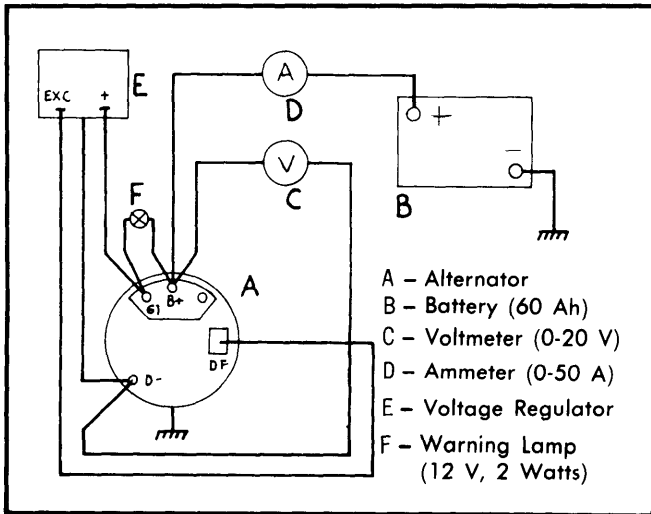

Fig. 1 Regulator Test Circuit

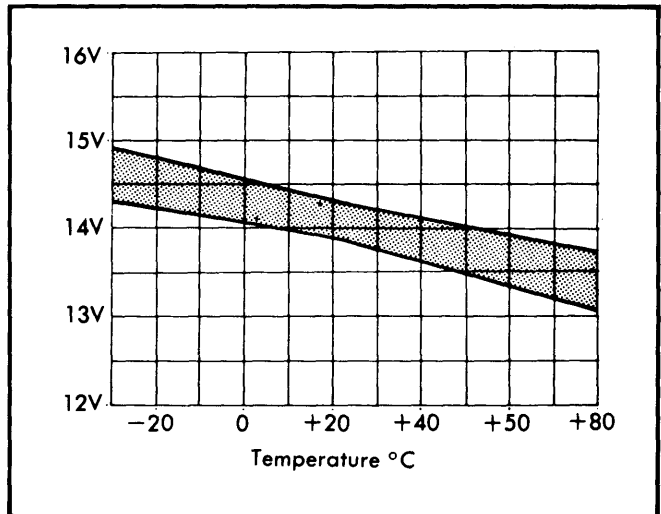

Fig. 2 Voltage-Temperature Variation with Regulator Warm.