

Alternators & Regulators

MITSUBISHI REGULATORS

Arrow
Colt
Courier
Mazda

ADJUSTMENT

Adjust voltage of the constant voltage relay by bending end of coil side plate up or down as shown in illustration. If plate is bent up, the adjusted value becomes higher. If it is bent down, value becomes lower. Adjust pilot lamp relay by same method.

DESCRIPTION

Regulator consists of two elements: constant-voltage relay and pilot lamp relay. Both relays consist of an electromagnet, contacts, frame, moving element and coil side plate. This regulator has a temperature compensation gradient as an improvement over the constant voltage charging system. It has functions for automatically compensating the adjusted value of the constant-voltage relay so that the adjusted value will be lower in summer and higher in winter.

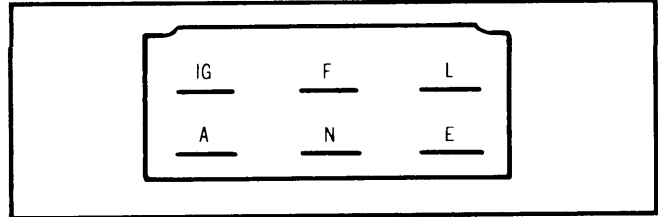

Fig. 1 Regulator Harness Connector

APPLICATION

| Model | Part No. |
|--------------------|--------------|
| Arrow & Colt | RQB-2D |
| Courier | D27Z-10316-A |
| Mazda | 0453 18 391 |

TESTING

To check adjusted value of constant voltage relay, connect a voltmeter between terminal "A" and "E" of the regulator. Place generator at no load by disconnecting one of the battery terminals during operation at idling speed, then increase alternator speed to approximately 4000 RPM (Approximately 2000 engine RPM). In this condition, satisfactory voltage is 14.5-15.8 volts.

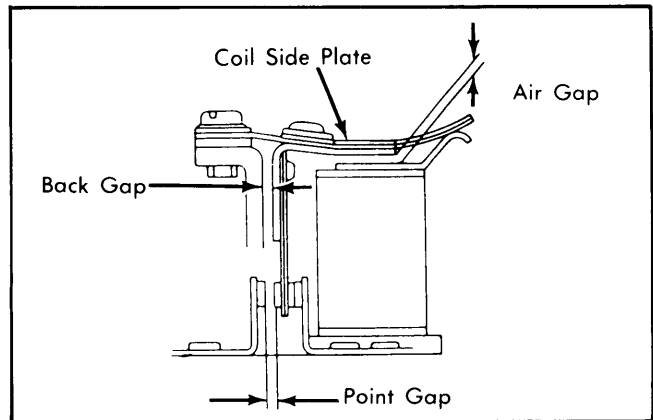

Fig. 2 Voltage Adjustment Point

MITSUBISHI ALTERNATOR REGULATOR SPECIFICATIONS

| Reg. No. | VOLTAGE REGULATOR | | | | PILOT LAMP RELAY | | |
|-----------|-------------------|------------------------|------------------------|------------------------|------------------------|------------------------|------------------------|
| | Output Volts | Air Gap in. (mm) | Back Gap in. (mm) | Point Gap in. (mm) | Air Gap in. (mm) | Back Gap in. (mm) | Point Gap in. (mm) |
| RQB-2D | 14.5-15.3 | .032-.047 (.81-1.2) | .032-.043 (.81-1.1) | .012-.016 (.31-.41) | .035-.047 (.89-1.2) | .030-.043 (.76-1.1) | .030-.043 (.76-1.1) |
| 045318391 | 13.5-14.5 | .028-.051 (.71-1.3) | .028-.059 (.71-1.5) | .012-.018 (.31-.45) | .039-.051 (.89-1.4) | .028-.059 (.71-1.5) | .020-.035 (.71-1.1) |
| D27Z-A | 14-15 | | | | | | |