

## COURIER

### INSTRUMENT CLUSTER

Disconnect battery ground cable. Remove four screws securing cluster to instrument panel. Pull cluster out sufficiently to gain access and disconnect speedometer cable and wiring. Remove cluster from vehicle.

### SPEEDOMETER & GAUGES

Speedometer and all gauges may be removed after first removing instrument cluster.

### HAZARD WARNING FLASHER

Flasher is located to the left of the steering column beneath instrument panel.

### TURN SIGNAL FLASHER

Flasher is located to the right of the steering column beneath instrument panel.

### IGNITION SWITCH

Disconnect battery ground cable. Reach behind instrument panel and disconnect wiring from switch. While holding switch from back, remove black retaining nut and remove switch.

### STOP LIGHT SWITCH

Mechanical type mounted on bracket at top of brake pedal.

## DATSUN

### INSTRUMENT CLUSTER

**B210** — 1) Disconnect battery ground cable and remove shell covers. **NOTE** — To facilitate removal of cluster, remove steering wheel and turn signal switch. Pull out ashtray and remove ashtray cover. Remove switch knobs and retaining rings.

2) Remove radio knobs and retaining knobs, if equipped. Remove nine screws securing cluster cover to dash (four on upper side, three under cover, one at ash tray outer case and one in glove box). Pull cluster cover out slightly and disconnect wiring. Remove cluster cover.

3) Remove four instrument cluster retaining screws and pull cluster out slightly. Disconnect wiring and speedometer cable. Remove instrument cluster assembly.

**610** — Remove steering column shrouds and cluster cover. Remove two retaining screws and pull cluster cover forward, disconnect all wiring and speedometer cable. Remove cluster cover from panel. Remove odometer knob, if equipped, remove attaching screws and instrument cluster.

**710** — 1) Disconnect battery and remove steering column shrouds. **NOTE** — To facilitate removal of cluster, remove steering wheel and turn signal switch. Remove wiper switch and light control switch knob and retaining rings, two retaining screws and remove lower center cover.

2) Remove ashtray and disconnect wiring to cluster. Remove ten screws from cluster cover (five on upper edge, three below cover, one on ashtray cover and one under lower center cover). Disconnect speedometer cable and fibre optics and remove cluster cover. Remove odometer knob and six screws securing cluster. Remove instrument cluster.

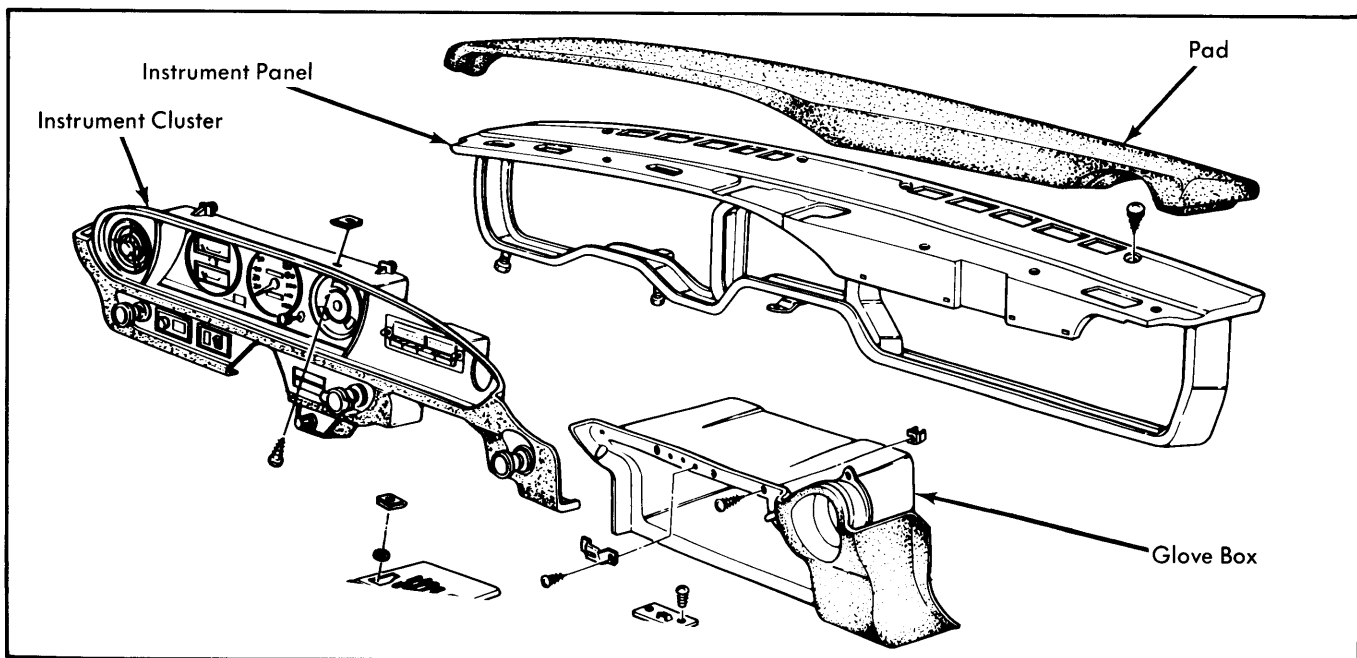

Fig. 4 Typical Datsun Instrument Cluster

## DATSUN (Cont.)

**620 Pickup** — Disconnect battery ground cable. Remove screws securing cluster to instrument panel and from under panel remove screw securing cluster to dash. Withdraw cluster slightly, then from behind cluster disconnect speedometer cable and wiring. Remove screws securing cluster cover to cluster and remove cluster assembly.

**F-10** — Disconnect battery, speedometer cable and remove ash tray. Disconnect heater control cables and all wire harness connectors.

**NOTE** — Tag wires for correct installation.

Remove steering column bracket bolts, loosen instrument panel upper attaching screws, remove side panel bolts and bolts attaching instrument panel to pedal bracket. Draw instrument panel out backwards. To install, reverse removal procedure.

**280Z** — 1) Disconnect battery. Remove steering wheel and screws securing garnish to panel. Remove garnish. Remove screws securing upper instrument to cowl top panel, finisher to instrument and detach finisher. Remove floor console, air control screws, floor tunnel screws, side ventilator control bracket screws and screws from each side of lower instrument panel.

2) Disconnect speedometer cable and instrument harness as follows:

- Junction Block
- Combination Switch
- Ignition Switch
- Stop Light Switch
- Flasher Units
- Door Switch

To install, reverse removal procedure.

### SPEEDOMETER & GAUGES

**All Exc. 280Z Models** — Speedometer and all gauges may be removed after removing instrument cluster.

**280Z Models** — Speedometer, tachometer and all gauges are removed individually from instrument panel. All units are secured at back with wing nuts. To remove center gauges, first remove center console trim.

### IGNITION SWITCH

**All Models** — Remove steering column shrouds and disconnect wiring. Remove switch retainer screw at bottom of lock and remove switch. To remove lock assembly, drill out shear bolts and remove assembly.

## FIAT

### INSTRUMENT CLUSTER

Disconnect battery. Remove five screws holding cluster to panel, slide cluster forward and disconnect electrical connectors and speedometer cable. Remove instrument cluster.

### SPEEDOMETER & GAUGES

Speedometer and all gauges may be removed after removing instrument cluster.

### IGNITION SWITCH

Ignition switch is keyed and has four positions. Key can be removed with engine running. Key can also be fitted with an anti-theft device which locks the steering shaft.

### STOP LIGHT SWITCH

Mechanical type mounted on brake pedal bracket.

## HONDA

### INSTRUMENT CLUSTER

Disconnect battery ground cable and remove three cluster mounting wing nuts from rear of cluster. Disconnect speedometer and tachometer (if equipped) drive cables from engine. Pull cluster away from panel and disconnect wiring, speedometer and tachometer (if equipped) drive cables from cluster. Remove cluster.

### SPEEDOMETER, TACHOMETER & GAUGES

Speedometer, tachometer (if equipped) and all other gauges may be removed after first removing instrument cluster.

### STOP LIGHT SWITCH

Mechanical type mounted on brake pedal bracket. Switch also serves as brake pedal stop. Adjust switch to give .039-.196" (1-5 mm) freeplay at center of brake pedal.

## JAGUAR

### INSTRUMENT CLUSTER

**Sedan Models** — Disconnect battery. Remove two knurled screws and hinge down instrument cluster. Disconnect voltage stabilizer and wiring, remove four setscrews and remove cluster. Individual instruments may now be removed from cluster.

### SPEEDOMETER & TACHOMETER

Speedometer and tachometer may be removed by disconnect wiring and speedometer drive cable and releasing securing clamps.