

NIPPONDENSO

DESCRIPTION

The starter solenoid is an electromagnetic switch, activating a plunger by means of a "pull-in" coil and a "hold-in" coil. The plunger is pulled in, which engages the starter, and then is held in, while the engine starts. When the hold-in coil is activated the pull-in coil is short circuited and only the hold-in coil remains effective. When the current flow to the starter is stopped, the hold-in force is lost and the plunger returns to its rest position.

TESTING

All tests should be performed with the starter assembled and the "F" (field) lead from the starter disconnected at the solenoid.

NOTE — If plunger and or sleeve are corroded, clean with fine sand paper and alcohol, and blow out with air before performing tests.

Pull-In Test — Apply 8 volts momentarily between the "50" terminal and the "F" terminal of the solenoid. If the plunger is pulled in strongly the pull-in coil is satisfactory.

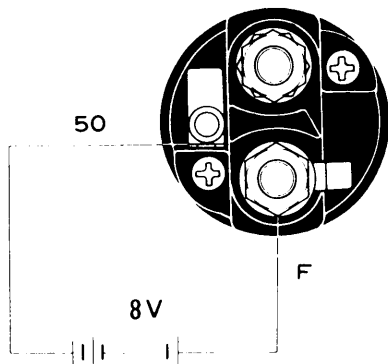

Fig. 1 Test Connections for Pull-In Coil

Hold-In Test — Connect leads from an 8 volt source onto the solenoid case and to the "F" terminal. Connect a jumper wire

between "F" terminal and the "50" terminal. This will pull-in the plunger. Disconnect the jumper wire from the "F" terminal and if the plunger remains held in, the hold-in coil is satisfactory.

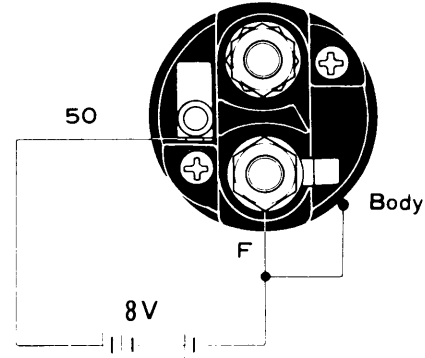

Fig. 2 Test Connections for Hold-In Coil

Plunger Return Test — Apply 12 volts between "F" terminal and solenoid case. Pull out starter pinion gear with fingers until it stops. If plunger returns to original position when pinion is released, solenoid is satisfactory.

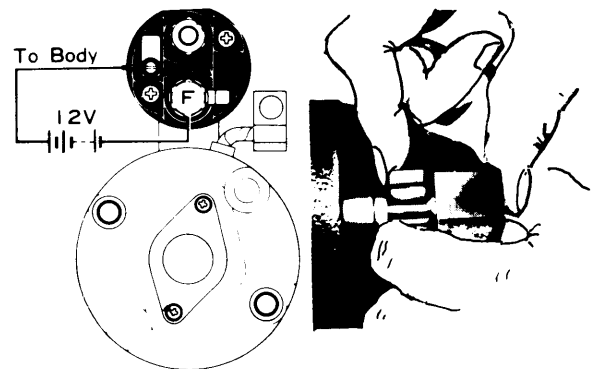

Fig. 3 Test Connections for Plunger Return.

Solenoid Resistance Values

Pull-In Coil — About 0.4 ohms
 Hold-In Coil — About 1.1 ohms