

SEV MOTOROLA ALTERNATORS

Porsche

SPECIFICATIONS

► CHANGES, CAUTIONS, CORRECTIONS

► **BATTERY INSTALLATION & OTHER ELECTRICAL REPAIRS**
CAUTION — Reversed polarity or excessive voltage will result in extensive damage to alternator system. Note the following to prevent damage:

Battery Installation — Negative battery terminal must be connected to ground (negative ground system) and positive terminal must be connected to starter. **DO NOT** reverse battery leads.

Battery Charging — If a Quick Charger is used, both battery cables must be disconnected from the battery. **DO NOT** use a Quick Charger to provide starting voltage.

Circuit Interruption — The battery must **NEVER** be disconnected while alternator is running.

Alternator Removal — Always disconnect battery ground before replacement of alternator.

High Voltage — **DO NOT** use a high voltage source to test diodes.

Booster Battery (For Engine Start) — Booster battery must be connected with negative lead to negative battery terminal and positive lead to positive battery terminal. **DO NOT** reverse battery leads.

Field Terminal — **NEVER** ground field energizing terminal on alternator, regulator, or connecting lead.

Voltage Regulator — **NEVER** operate voltage regulator without a good ground connection or immediate damage will result.

DESCRIPTION

SEV Motorola alternators are conventional three-phase, self-rectifying type alternators. Six silicon diodes (three positive and three negative) are used to rectify AC current.

APPLICATION

| Model | Rating | Part No. |
|--------------------------------|---------------|-----------------|
| Porsche 911 & Carrera | 70 Amps | ⓐ911 603 120 00 |

ⓐ — Porsche part number.

Nominal Output

| Application | Voltage |
|---------------|---------|
| Porsche | 14 |

TESTING

ON CAR TEST

Connect alternator as shown in Fig. 1. Check that current through field winding (rotor) is 3.0-3.5 amperes. If current is not within specifications, check field winding condition and brush holder. Run engine speed to 1500 RPM. Alternator should then produce the specified current. Measure voltage at terminal "B+" and at terminal "61". Voltage should be .8-.9 volts more at terminal "61". If not, isolation diodes are faulty and should be replaced.

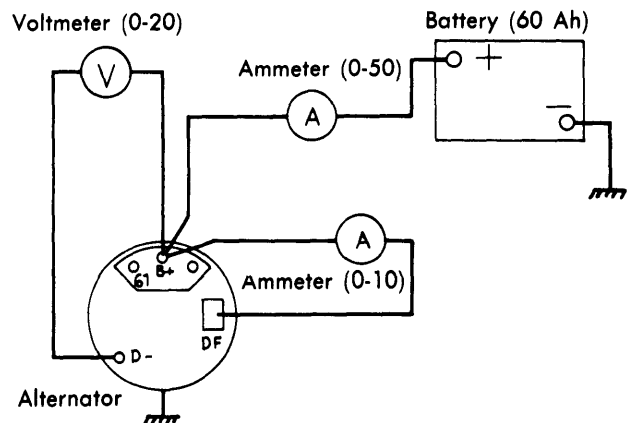

Fig. 1 Test Connections for Alternator

OVERHAUL

DISASSEMBLY

- 1) Remove two screws holding brush holder and remove isolation plate (if equipped). Carefully lift out brush holder.
- 2) Hold pulley with belt in a vise with soft jaws, and remove the nut and washer. Lift off pulley, fan, key and spacer washer.
- 3) Remove nuts and washers on terminal 61 and the corresponding terminal on other side of isolation diode. Mark drive shield, stator and slip ring end shield for correct reassembly position.

SEV MOTOROLA ALTERNATORS (Cont.)

- 4) Remove four attaching screws. Remove rotor and drive end shield with help of two screwdrivers, which are inserted in two sockets between stator and drive end shield. **CAUTION** — The screwdrivers may not be inserted deeper than $\frac{1}{16}$ " (2 mm); otherwise stator may be damaged.
- 5) Release three screws holding support plate of drive end bearing. Release bearing by knocking end of shaft against a piece of wood.
- 6) Remove nuts and washers for the diode holder for negative diodes. Remove stator and diode holders for slip ring end shield.

TESTING

Stator — Check stator for short-circuiting. If one or more of the coils are burned, there must be a short-circuit in stator. Connect test lamp (12 volt, 2-5 watt) between stator plates and a terminal on stator (see illustration). If lamp lights, isolation between stator winding and stator plates must be burned, in which case stator should be replaced. **NOTE** — Use only test lamp as specified. **DO NOT** use a 110-volt or 220-volt test lamp on this or any alternator test procedure.

Diodes — Check diodes with a diode tester. If any of the rectified diodes are shorted or open, the diode holder must be replaced. If any isolation diode is faulty, replace holder, complete with isolation diodes. If diode tester is not available, diodes should be unsoldered and tested with an ohmmeter. Diodes should show high resistance in reverse direction and low resistance in flow direction.

Rotor — Check to make sure slip rings are not dirty or burned. Check winding for breakage or damaged isolation. Measure resistance between slip rings. It should be as specified. If winding is faulty, rotor must be replaced. **NOTE** — It is recommended that bearings be replaced whenever alternator is disassembled.

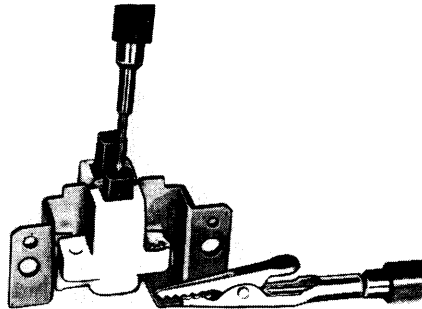

Fig. 2 Checking the Brush Holder

Brush Holder — Connect a test lamp between the brushes. Lamp should not light. Next connect test lamp between "DF" terminal and the "+" brush. Lamp should give steady light even if brush or terminal cable is moved (see illustration). Connect test lamp between brush holder frame and "-" brush. Lamp should give steady light. If test results are not satisfactory or brush length is less than $\frac{3}{16}$ " (5 mm), replace brush holder. **NOTE** — Brush length is measured between brush contact surface and holder, with brush resting against spring.

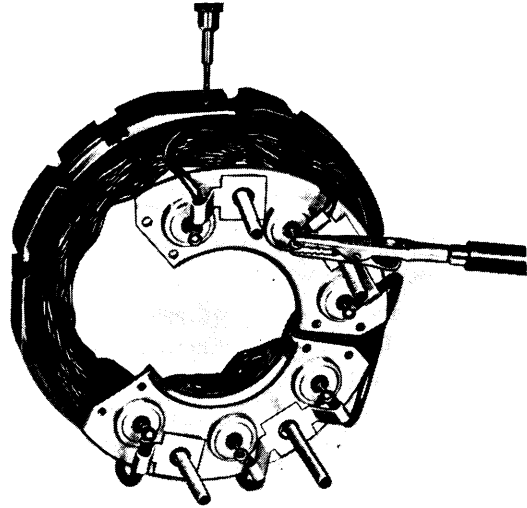

Fig. 3 Checking the Stator

PARTS REPLACEMENT

Diodes — Mark leads connecting stator to diodes, then unsolder leads. Place new diode holder in exact position of holder being replaced. Solder new leads, holding with pliers (this is to conduct heat from soldering point, to avoid damaging new diode). Use a minimum 100-watt, well-heated soldering iron. Never change places of diode holders. Positive holder is isolated from frame by means of isolation washers and sleeves and its diodes are marked in red. Negative diode holder is not isolated and its diodes are marked in black.

REASSEMBLY

Alternator is reassembled by reversing disassembly procedures while noting the following: Rotor must be pressed into drive end shield. Connect a test lamp between "B+" terminal and alternator frame, then reverse connections. Lamp should light only in one direction. After completion of reassembly, test run alternator on bench, using same procedure as described for On Car Testing.

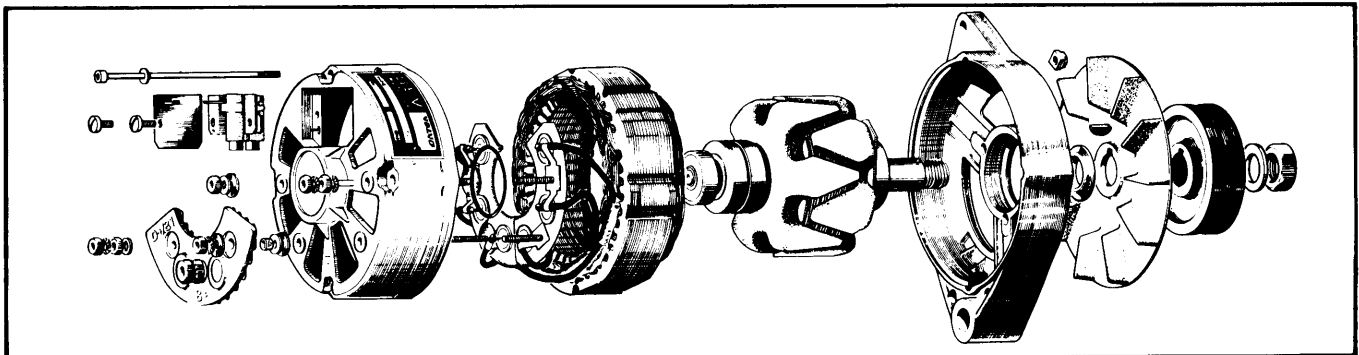

Fig. 4 Disassembled View of S.E.V. Motorola Alternator