

NIPPONDENSO REGULATORS

VOLTAGE RELAY

Honda
Opel Isuzu
Toyota

DESCRIPTION

Nippondenso regulators are of two designs: a single element type and a two element type. Two element types consists of a voltage regulator and voltage relay. The single element type has a voltage regulator only.

APPLICATION

Model	Part No.
Honda	
Accord	31100-671-004
Civic 4 Cyl.	31400-634-671
CVCC	31400-657-671
Opel Isuzu	
All Models	①94208462
Toyota	
2F Engine	
FJ40	27700-60090
FJ55	27700-24010
20R Engine	
HiLux	27700-38050
All Others	27700-38010
2TC & 4M Engines	27700-38010

① - Buick part number.

TESTING

VOLTAGE REGULATOR

Connect tests meters to voltage regulator circuit as shown in illustrations. Vary alternator RPM and check voltmeter reading. Increase alternator RPM and check voltage when ammeter registers 1/2 of maximum rated alternator output. Voltage should be 13.8-14.8 volts. Adjust alternator speed to 3,000 RPM, voltage output should again be 13.8-14.8 volts. If voltage is not within specified range, adjust voltage regulator by bending arm to obtain correct setting.

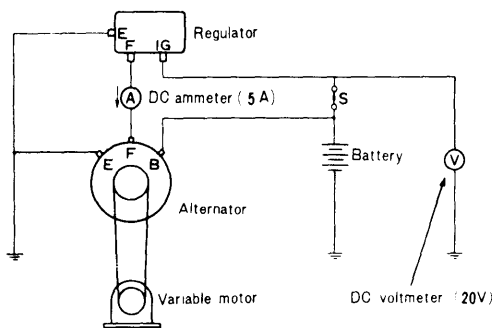

Fig. 1 Test Circuit for Single Element Type

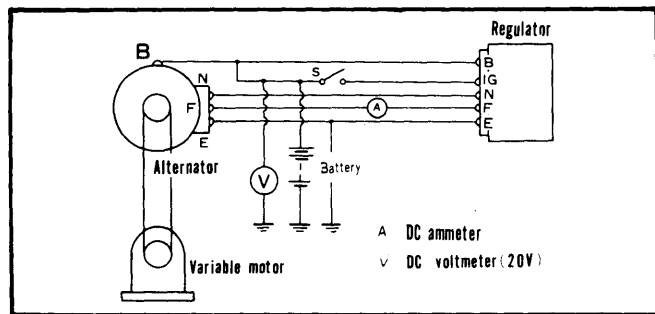

Fig. 2 Test Circuit for Two Element Type

Charge Warning Lamp Type - Connect test meters as shown in Fig. 3 thru 6. Increase alternator RPM gradually and note voltage when charge warning lamp goes out. Cut-in voltage should be 4.0-5.8 volts (Toyota 4M and 20R engines) or 4.5-5.8 volts (all others). If voltage is not as specified, bend voltage relay adjusting arm to obtain correct setting.

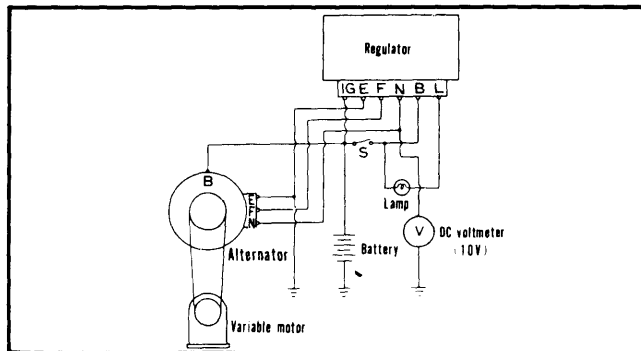

Fig. 3 Test Circuit for Relay-Warning Lamp Type

Ammeter Type - Connect test meters as shown in Fig. 4 thru 6. Increase alternator RPM gradually and note voltage. Voltage should be 4.5-5.8 volts. If necessary, adjust voltage by bending adjusting arm.

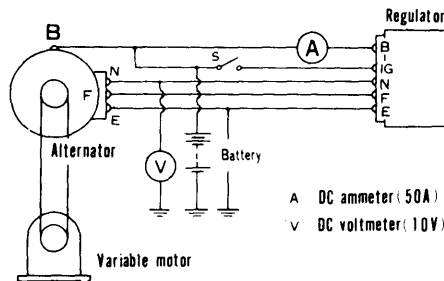

Fig. 4 Test Circuit for Relay-Ammeter Type

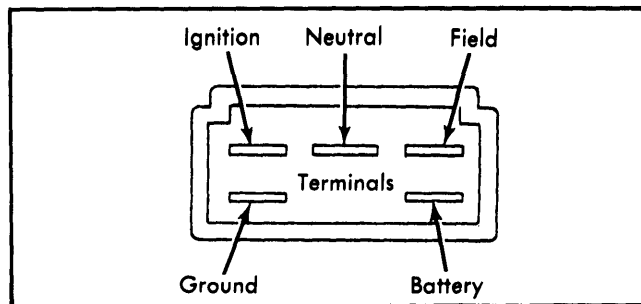

Fig. 5 Terminal Position for Two Element Type Regulator Wiring Connector

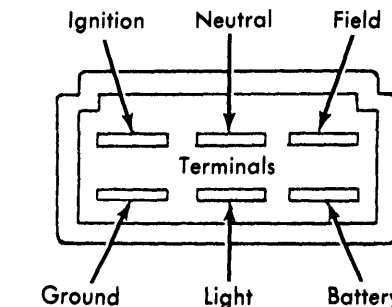

Fig. 6 Terminal Position for Two Element Regulator with Warning Lamp Circuit

NIPPONDENSO REGULATORS (Cont.)

ADJUSTMENT

NOTE — Adjustments are not applicable to sealed units. If points are slightly oxidized or pitted, dress contacts with suitable emery cloth (about 400 grit). If points are oxidized or pitted excessively, replace regulator assembly.

VOLTAGE RELAY

Contact Spring Deflection — Press on armature and use a feeler gauge to check clearance between armature and point spring. Clearance should be .008-.024" (.20-.60 mm) on Toyota 4M and 2TC engines and Honda CVCC. Clearance should be .008-.018" (.20-.45 mm) on all other models. Adjust by bending point holder "A" on relay unit.

Point Gap — Check point gap with a feeler gauge. Clearance should be .016-.024" (.41-.60 mm) on Toyota 4M engines. Clearance should be .016-.047" (.4-1.2 mm) on all other models. If necessary, adjust by bending point holder "B".

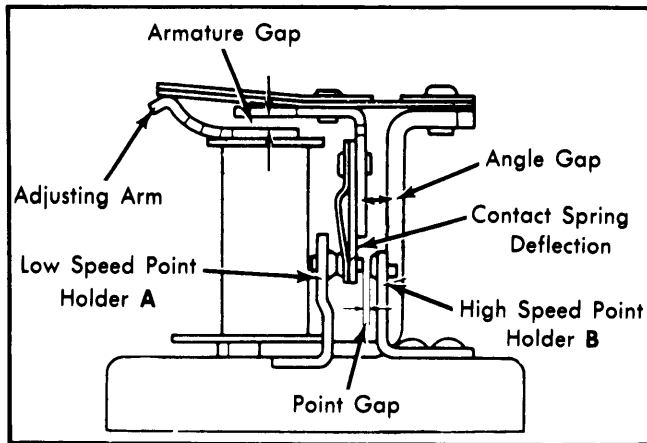

Fig. 7 Adjustments for Voltage Relay

VOLTAGE REGULATOR

Armature Gap — Check with a feeler gauge. Clearance should be .012" (.3 mm) on Toyota 4M and 2TC engines. Clearance should be .024-.032" (.6-.8 mm) on all other models. Adjust by bending point holder "A".

Point Gap — Check with a feeler gauge. Clearance should be .012-.018" (.30-.45 mm) on Toyota 4M and 2TC engines. Clearance should be .010-.018" (.25-.45 mm) on all other models. Adjust gap by bending spring holder "B".

Contact Spring Deflection — With armature depressed, check spring deflection with a feeler gauge. Specified deflection should be .008-.024" (.2-.6 mm). If deflection is not as specified, replace regulator assembly.

Angle Gap — With armature depressed, check gap with a feeler gauge (see illustration). Specified gap is .008" (.20 mm).

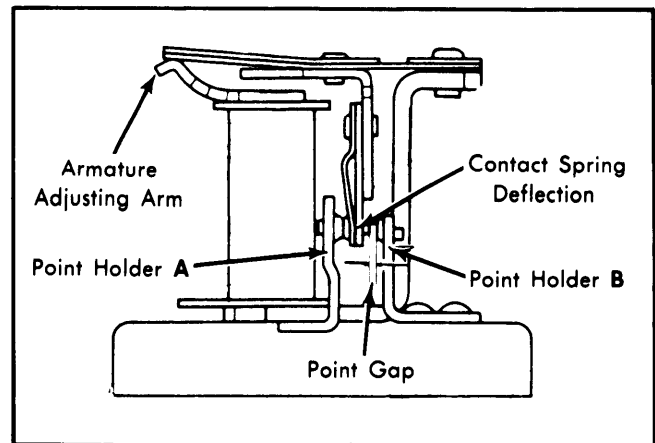

Fig. 8 Adjustments for Voltage Regulator