

Alternators & Regulators

NIPPONDENSO ALTERNATORS

Honda
Opel
Toyota

► CHANGES, CAUTIONS, CORRECTIONS

► **BATTERY INSTALLATION & OTHER ELECTRICAL SYSTEM REPAIR CAUTIONS** — Reversed polarity or excessive voltage will result in extensive damage to alternator system. Note the following to prevent damage:

Battery Installation — Negative battery terminal must be connected to ground (negative ground systems) and positive terminal must be connected to starter. DO NOT reverse battery leads.

Battery Charging — If a Quick Charger is used, both battery cables must be disconnected from battery. DO NOT use a Quick Charger to provide starting voltage.

Circuit Interruption — Battery must NEVER be disconnected while alternator is running.

Alternator Removal — Always disconnect battery ground before replacement of alternator.

High Voltage — DO NOT use a high voltage source to test diodes.

Booster Battery (For Engine Start) — Booster battery must be connected with negative lead to negative terminal of battery and positive lead to positive battery terminal. DO NOT reverse battery leads.

DESCRIPTION

Nippondenso alternators are conventional, three-phase, self-rectifying type alternators. Six diodes (three positive and three negative) are used to rectify current.

APPLICATION

Model	Amps ^①	Part No.
Honda		
Accord	50	31400-6-671
Civic	40	38760 634 811
CVCC	35	31100 634 004
Opel		
.....	40 ②
Toyota		
2TC Engine	40	36071
2F Engine		
Standard	40	60010, 60071
.....	50	60020
Heavy Duty	50	60030, 60040
W/Vac. Pump	50	60080
4M Engine	45	41032
20R Engine	40	38010
.....	45	34030

① — Rated output at 14 volts at 3000 RPM (Toyota), 2000 RPM (Honda) or 1400 RPM (Opel).

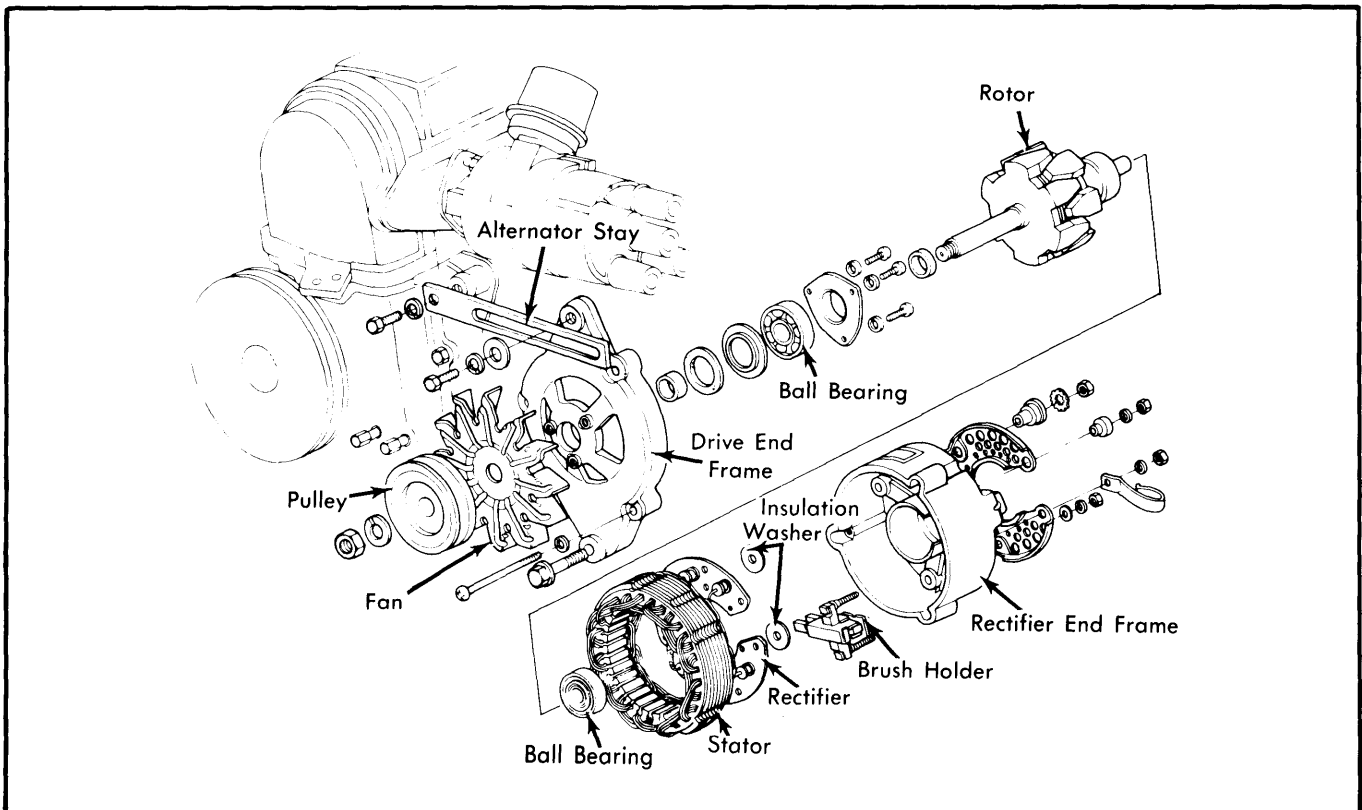

Fig. 1 Disassembled View of Nippondenso Alternator

NIPPONDENSO ALTERNATORS (Cont.)

SPECIFICATIONS

Coil Resistance (Ohms)

Application	Rotor
All Models	4.1-4.3

Minimum Brush Length

Application	In. (mm)
All Models22 (5.5)

TESTING

ON CAR TEST

Preliminary Inspection – Check alternator mounting and belt tension. Inspect turn signal fuse and gauge fuse. Check alternator and regulator wire connections for tightness.

No Load Test – 1) Connect a suitable test meter (09081-00010 alternator tester for models with special connector from regulator, or a common regulator tester) as shown in illustrations. Start engine and increase speed gradually to 2000-2300 RPM. Read "B" terminal voltage. Voltage should be 13.5-14.8 with a current draw of not more than 10 amps. If current is over specifications, battery is discharged or internally shorted.

2) If voltage reading is not steady, it indicates regulator points are dirty, or defective connection exists at "F" terminal.

3) If voltage reading is too high, it indicates the following problems: Regulator low speed gap is too wide. High speed point gap is too wide. High speed point resistance is too high. Open circuit regulator coil or voltage relay coil. Open circuited regulator coil or voltage relay coil. Open circuited regulator "N" terminal or "B" terminal. Low speed point contact tension too heavy. Loose regulator ground connection.

"F" Terminal Voltage Test – 1) With regulator tester, stop engine, disconnect alternator wiring connector, turn ignition switch to "ON" and measure voltage between "F" and "E" terminals of connector. Voltage should be 12 volts. If voltage is zero or very low, note the following possible causes; blown fuse, regulator "IG" terminal open, or regulator high speed points are burned.

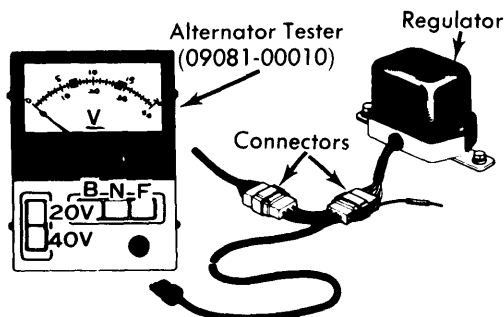

Fig. 2 Connections for Testing Alternator Using Tester 09081-00010

2) With alternator tester (09081-00010) connected and engine idling, press switch "F" on tester. Gradually increase engine speed to 2300 RPM. Needle on tester should deflect in small steps from 12-7 volts, 6-4 volts and 3-1 volts. If voltage does not drop as specified, regulator is defective or out of adjustment.

Regulator Circuit Resistance – Disconnect regulator connector plug and check resistance between regulator "IG" and "F" terminals with an ohmmeter. If there is any resistance, the low speed contact in regulator is defective.

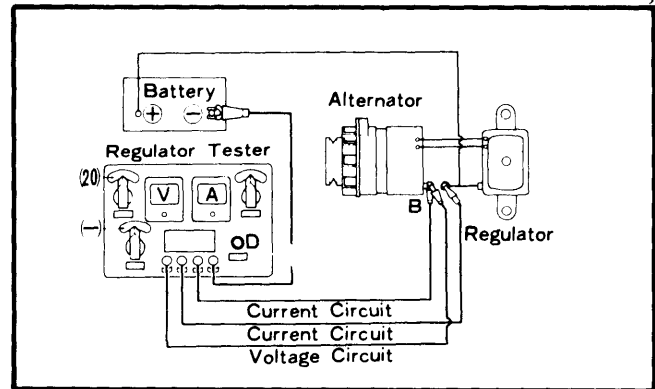

Fig. 3 Connections for Testing Regulator

Load Test – With regulator tester connected as shown in illustration, start engine and turn on all lights and accessories. Run engine at 1100 RPM. Read amperage and voltage. It should be as specified. If battery is fully charged and reading is low, discharge battery by cranking engine (without spark) for about 15 seconds. Now if amperage is low, the rectifiers are open, shorted, or stator coil is open or shorted.

OVERHAUL

DISASSEMBLY

1) Remove three retaining screws and insert screwdrivers into notches in drive end frame, pry with screwdrivers to separate drive end frame from stator. If necessary, tap lightly on drive end frame with a mallet.

2) Secure rotor core in padded vise, remove pulley attaching nut, and withdraw pulley, fan, and spacer. Remove rotor from drive end frame, utilizing a press. Remove bearing retainer from drive end frame, then remove bearing, felt cover and felt ring.

3) Remove four rectifier holder securing nuts and two brush holder securing screws; separate stator with rectifier holders and brush holders from rectifier end frame. Remove brush lead terminal and stator coil "N" terminal from brush holder, utilizing a small screwdriver. **CAUTION** – When removing brush holder assembly, do not remove it by cutting "N" terminal lead or melting the solder.

TESTING

Rotor – Check rotor for open field windings by connecting an ohmmeter across the slip rings. Coil resistance should be approximately as specified. Next check bearing and replace if necessary. Check slip rings for rough condition.

NIPPONDENSO ALTERNATORS (Cont.)

Stator — Use ohmmeter to check stator coil for ground. To check stator for open circuit, stator leads must be disconnected from diode leads. To disconnect leads from diodes, unsolder as quickly as possible and with a low-watt iron. Check four leads of stator coil for conduction between each lead. If ohmmeter shows no conduction, stator coil is open and must be replaced. Resistance should be zero.

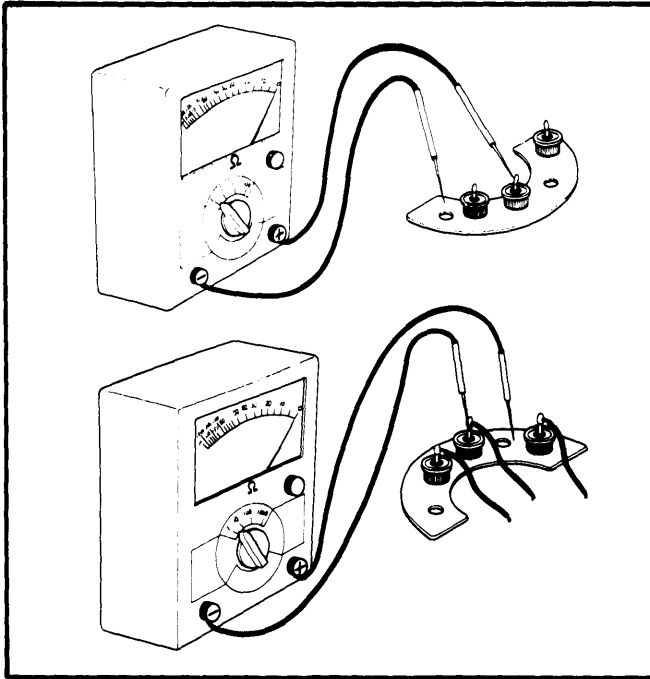

Fig. 4 Testing the Diodes

Diode Test — With diode assembly on bench, make test connections as illustrated, using an ohmmeter. Contact diode plate with one probe and contact each of the three diode leads with other probe. Note ohmmeter reading, then reverse probes and repeat test. Check both positive and negative diodes in this manner. All diodes should show a low reading in one direction and no reading in opposite direction. If any one rectifier is defective, always replace positive or negative holder assembly.

PARTS REPLACEMENT

Brushes — Check for cracks and wear. If brushes are worn beyond specifications, replace. Brushes should slide smoothly. Install new brush spring when replacing brush. Solder brush lead wire keeping protruded length to .51" (13 mm).

REASSEMBLY

Reassemble alternator by reversing disassembly procedure, noting the following points:

- 1) Press brushes, against spring tension, into brush holder. Insert a wire through access hole in rectifier and frame, and into hole in brush holder. This will prevent brushes from falling. Remove wire after assembly to end frame is completed.
- 2) Pack multipurpose grease into rear bearing and press bearing onto rotor shaft.
- 3) Install felt ring and felt cover so that convex surface of cover will face toward pulley side onto drive end frame. Next pack multipurpose grease into bearing and install bearing.