

## LUCAS ALTERNATOR WITH INTEGRAL REGULATOR

Jaguar  
MG  
Triumph

### ► CHANGES, CAUTIONS, CORRECTIONS

► **BATTERY INSTALLATION & OTHER ELECTRICAL SYSTEM REPAIR CAUTIONS** — Reverse polarity or excessive voltage will result in extensive damage to alternator system. Note the following to prevent damage:

**Battery Installation** — Negative battery terminal must be connected to ground (if negative ground system) and positive terminal to starter. DO NOT reverse battery leads.

**Battery Charging** — If a Quick Charger is used, both battery cables must be disconnected from the battery. DO NOT use a Quick Charger to provide starting voltage.

**Circuit Interruption** — Battery must NEVER be disconnected while alternator is running.

**Alternator Removal** — Always disconnect battery ground before replacement of alternator.

**High Voltage** — DO NOT use a high voltage source to test diodes.

**Booster Battery (For Engine Start)** — Booster battery must be connected with negative lead to negative terminal of battery and positive lead to positive terminal of battery. DO NOT reverse battery leads.

### DESCRIPTION

Lucas "ACR" model alternators have an integral voltage regulator mounted in the slip ring end bracket. The stator consists of star-connected, three phase windings on a ring end

cover and drive end bracket. The rotor is either an eight or twelve pole type with the field windings connected to two face-type slip rings, and is supported in drive-end bracket by a ball bearing and in the end cover by needle roller bearings. One positive and one negative carbon brush ride against concentric brass slip rings. The heatsink-rectifier, terminal block assembly incorporate six silicon diodes, forming a full wave rectifier bridge circuit, and three diodes which supply current to the rotor windings. **NOTE** — Up to a ten milliamp battery drain is normal, even with the ignition in the "OFF" position.

### APPLICATION

Model	Type No.
Jaguar	
XJ-6 Without Air Cond. ....	18 ACR
XJ-6 With Air Cond. ....	20 ACR
XJ-12, XJS .....	20 ACR
MG .....	16 ACR
Triumph	
Spitfire 1500 .....	16 ACR
TR-6 .....	18 ACR
TR-7 .....	20 ACR

### SPECIFICATIONS

#### Nominal Output

Alternator	Amps @ RPM	Voltage
16 ACR .....	34 @ 6000 .....	12
18 ACR .....	43 @ 6000 .....	12
20 ACR .....	66 @ 6000 .....	12

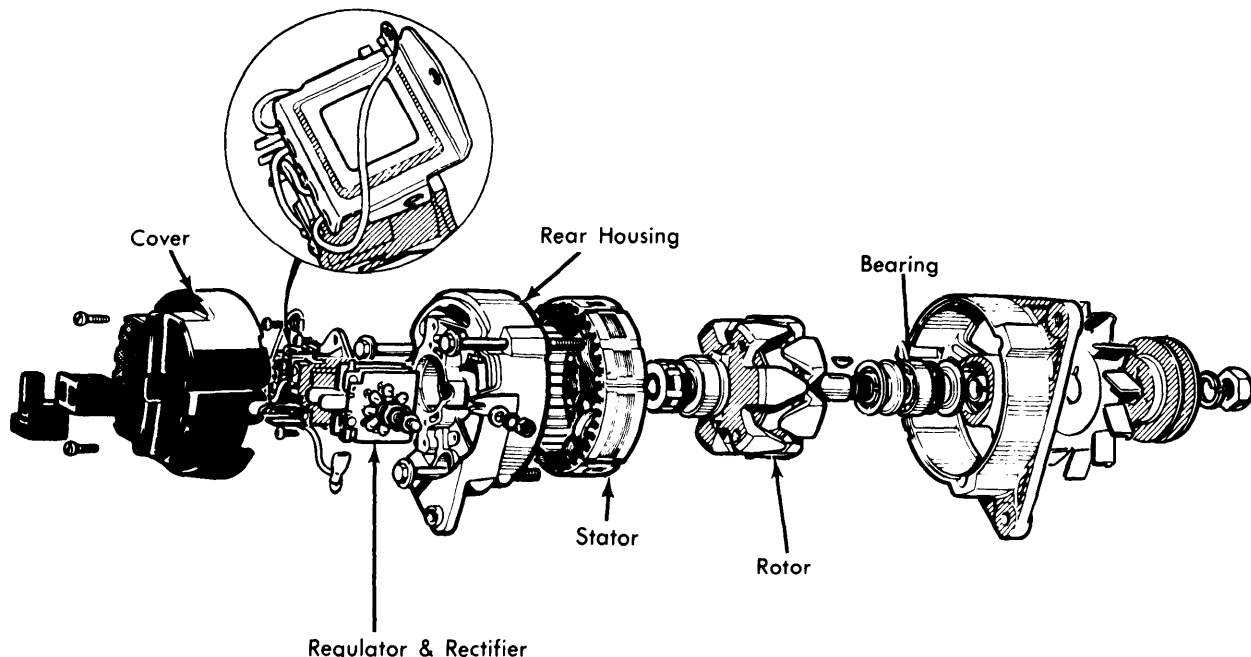

Fig. 1 Disassembled View of Lucas Integral Regulator Alternator Assembly

## LUCAS ALTERNATOR WITH INTEGRAL REGULATOR (Cont.)

### TESTING

#### ON CAR TESTING

##### Testing Alternator Output With Regulator Inoperative -

1) Disconnect alternator harness connector. Unscrew molded cover from rear of alternator. Link together regulator negative terminal and "F" terminal. Connect an external test circuit as shown in lower half of illustration. **CAUTION** - Be aware of proper connections to avoid reversed polarity.

2) **NOTE** - Variable resistor across battery terminals must not be left connected any longer than necessary to complete the test. Start engine and run at 800 RPM (1500 alternator RPM). The test circuit bulb should now be out.

3) Increase engine speed to 3200 RPM (6000 alternator RPM) and adjust variable resistance until voltmeter reads 14 volts. Ammeter reading should then be approximately specified rated output. If obvious variance from specifications is encountered, alternator necessitates removal and overhaul or replacement.

**Regulator Test** - **NOTE** - The following test assumes alternator is satisfactory. - 1) Disconnect variable resistor and remove link bridging regulator negative and "F" terminals. With remainder of test circuit still connected, start engine and run up to 3200 RPM (6000 alternator RPM), until ammeter registers output current of less than 10 amps. Voltmeter should then read 13.6-14.4 volts. Any variation necessitates regulator replacement.

2) If regulator is still shown to be satisfactory, disconnect entire external test circuit and reconnect alternator harness connector. Attach a low-range voltmeter between either positive alternator terminal and positive battery terminal.

3) Turn on headlights, start engine and increase engine speed to 3200 RPM. Record voltmeter reading. Transfer voltmeter connection to alternator frame and negative battery terminal. Record reading. If reading exceeds 0.5 volt on positive side or 0.25 volt on negative side, there is a high resistance in charging circuit which must be traced and corrected. See further testing on Overhaul procedure.

### OVERHAUL

#### DISASSEMBLY

1) Unscrew cover retaining screws and remove cover. Unsolder three stator connections from rectifier pack, noting positions. Remove two brush molding securing screws, loosen rectifier pack retaining nuts, and withdraw brush molding and rectifier pack.

2) Remove three through bolts. Remove bearing, by slipping a tube over slip ring molding until it is even with outer track of slip ring end bearing, then drive bearing from its housing. Remove shaft nut, pulley, and shaft key. Press rotor from drive end bracket. Remove circlip retaining the drive end bearing and remove bearing. Unsolder field connections from slip ring assembly and withdraw assembly from rotor shaft. Remove slip ring end bearing.

**Regulator Removal** - Disconnect colored tag lead connectors from brush box and detach ground lead after removing lower mounting screw or brush box retaining screw. Remove other retaining screw and withdraw regulator.

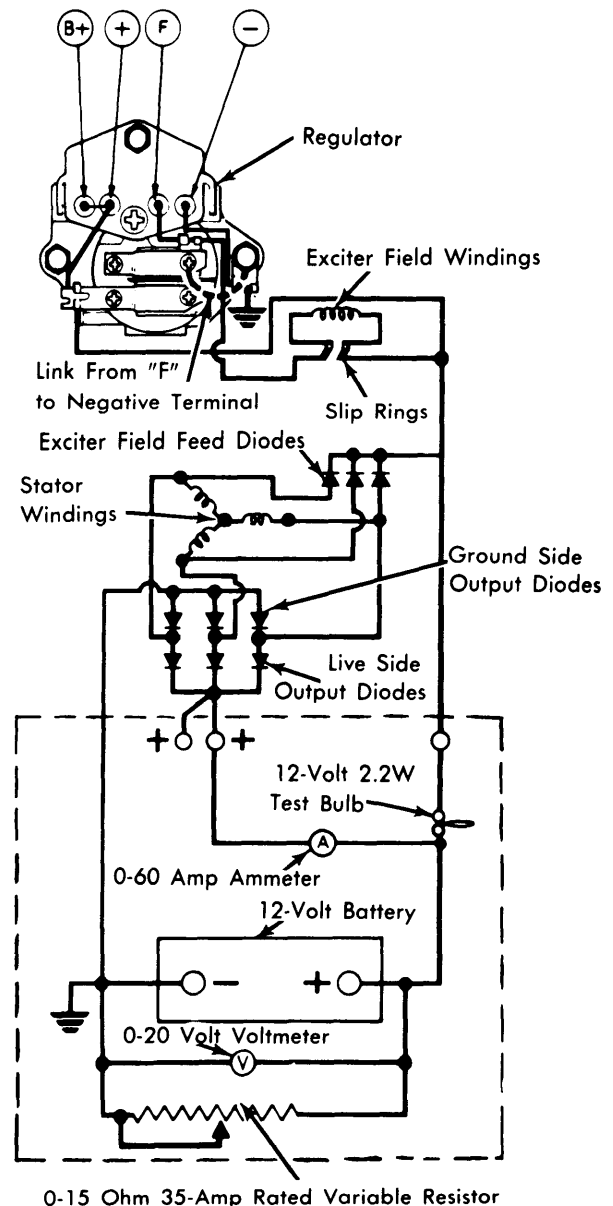

Fig. 2 Alternator Output Test Circuit

---

## LUCAS ALTERNATOR WITH INTEGRAL REGULATOR (Cont.)

### TESTING

**Rotor** – Connect an ohmmeter and read resistance of field coil (across slip rings). Using a 110-volt A.C. supply and 15-watt test lamp, check for insulation between one of the slip rings and any rotor pole. If lamp lights, rotor is shorted.

**Stator** – Connect 12-volt battery and 36-watt test lamp to two of the stator connections. Then repeat test using any other combination of two of the three connections. If lamp fails to light in either test, stator has an open coil. Using a 110-volt A.C. supply and a 15-watt test lamp, check for insulation between any one of the three stator connections and stator laminations. If lamp lights, stator should be replaced.

**Diodes** – Connect a 12-volt battery and a 1.5-watt test lamp in turn to each of the nine diode pins and its corresponding heat sink on the rectifier pack, then reverse the connections. Lamp should light (with current flow) in one direction only. If lamp lights in both directions or fails in either, rectifier pack must be renewed.

### PARTS REPLACEMENT

**Diodes** – If a defective diode is detected, the rectifier pack must be replaced as a unit.

**Brushes** – If length of brush protruding beyond brush box molding is .2" (5 mm) or less, the brush must be replaced. Check brush spring pressure, using a push type spring gauge. Gauge should register 9-13 oz. when brush is pushed back flush with housing. If reading is outside limits, place brush assembly.

### REASSEMBLY

Reverse disassembly procedure, noting the following: When installing slip ring end bearing, ensure it is fitted with open side facing rotor and that it is seated fully. When replacing rotor to drive end bracket, support inner track of bearing with suitable piece of tubing. DO NOT use drive end bracket as the only support for bearing when fitting rotor.