

NIPPONDENSO REDUCTION GEAR

Honda
Toyota

DESCRIPTION

Starter is a 12 volt, four brush, solenoid actuated, gear reduction type and is equipped with an overrunning clutch. Brushes are held in place by coiled springs of the brush holder located in the switch assembly housing. Starters used on the Toyota 2T-C engines have two ratings, 1 kilowatt and 1.4 kilowatt. Testing and service is the same on all starters.

APPLICATION

Model	Part No.
Honda	
CVCC Engine	31200-657-004
Toyota	
2T-C Engine	
1KW Calif.	26060, 26061, 26062
1KW Fed.	26040, 26041, 26042
1.4KW All	26050, 26051, 26052
20R Engine	34041, 34042
	34043, 34044
4M Engine	45022, 45030
	45031, 45032

TESTING

PERFORMANCE TESTS

No Load Tests – With starter motor connected to a 12 volt battery, connect an ammeter in series (Fig. 1) with starter. Connect voltmeter in parallel with battery. Compare readings with specifications.

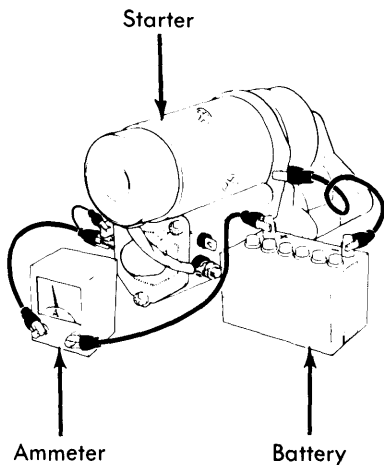

Fig. 1 Ammeter Hook-Up for No Load Test (Toyota Shown)

Cranking Test (Honda Only) – With starter in vehicle, disconnect battery ground cable and connect one ammeter connector to negative battery post and the other ammeter connector to the ground cable. Connect one voltmeter connector to the ground cable and the other connector to the battery positive post. Crank engine and observe readings. Readings should be a maximum of 160 amps at 9.6 volts.

No Load Specifications

Application	RPM	Amps@Voltage
Honda		80 @ 11.5
Toyota		
2T-C		
1KW	3500	90 @ 11.5
1.4KW	4000	90 @ 11.5
20R	3500	80 @ 11.5
4M	3500	80 @ 11.5

OVERHAUL

DISASSEMBLY

1) With starter removed from vehicle, disconnect wire(s) to magnetic switch. Remove bolts and remove field frame with armature from magnetic switch. Remove "O" ring and felt seal.

2) Remove screws and then remove starter gear housing from magnetic switch. Pull out clutch assembly and gears. Remove ball from clutch shaft hole or from magnetic switch. Remove brushes from brush holder then pull armature out of field frame.

PARTS REPLACEMENT & TESTING

Brushes & Springs – Measure brush length and replace if less than specified. Check brush spring tension with suitable spring scale and replace if tension is less than 2.6 lbs. (1.2 kg) or more than 4.3 lbs. (1.96 kg). Check insulation between the plus and minus brush holders, repair or replace if continuity is shown. Check condition of brush holders and spring clip, repair or replace parts as necessary.

Brush Length

Application	In. (mm)
Honda394-.571 (10-14.5)
Toyota394-.571 (10-14.5)

Commutator – Inspect commutator for roughness, if surface is pitted or grooved, it should be sanded lightly with a no. 500 emery paper. Also check commutator for being out-of-round. If out-of-round is more than .002" (.05 mm), turn commutator in a lathe until out-of-round is less than .002" (.05 mm). Insulating mica should be undercut to a depth of .024-.035" (.6-.9 mm) if it is less than .008" (.2 mm). Wear or cutting limit of commutator is 1.14" (29 mm).

Armature Coil – Check commutator and armature coil core for continuity, if continuity exists, replace armature. Check armature with an armature tester (growler) for shorts, if shorts exist, replace armature. Check for continuity between segments on commutator, if no continuity exists replace armature.

Field Coil – Check field coil for open circuits. There should be continuity between lead wire and field coil brush lead, if not, replace field coil. Check for no continuity between field coil end and end frame, if continuity exists, replace field coil.

Overrunning Clutch Assembly – Inspect gear teeth for wear and damage. Replace gears if damaged. Also, if gears are damaged, check flywheel ring gear. Rotate pinion. Pinion should rotate freely in a clockwise direction and lock up in a counterclockwise direction.

Starters

NIPPONDENSO REDUCTION GEAR (Cont.)

Bearings – Turn each bearing by hand, replace bearings if they stick or have a high resistance to turning.

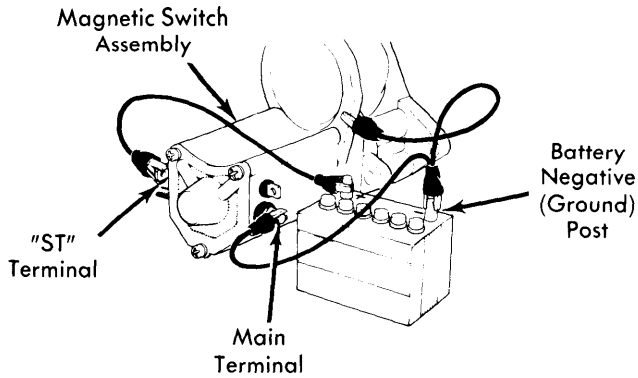

Fig. 2 Magnetic Switch Pull-In Coil Hook-Up

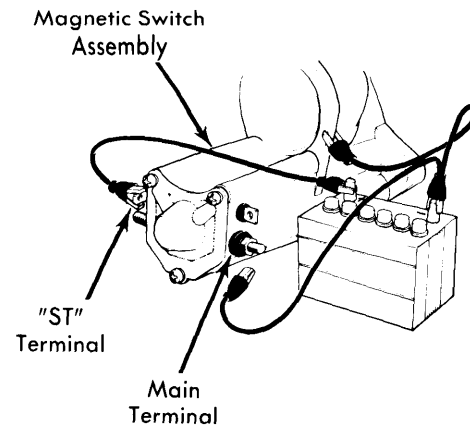

Fig. 3 Magnetic Switch Hold-In Test Hook-Up

Magnetic Switch Assembly – Connect a 12 volt battery to magnetic switch "ST" terminal, main terminal and ground (Fig. 2). Plunger should extend firmly, if not, replace magnetic switch. Next disconnect battery from main terminal. (Fig. 3) Plunger should remain extended, if not, replace magnetic switch.

REASSEMBLY

To reassembly, reverse disassembly procedure and note the following: Use a high temperature grease on bearings, gears and clutch assembly. **NOTE** – Apply grease to clutch shaft hole and insert ball.

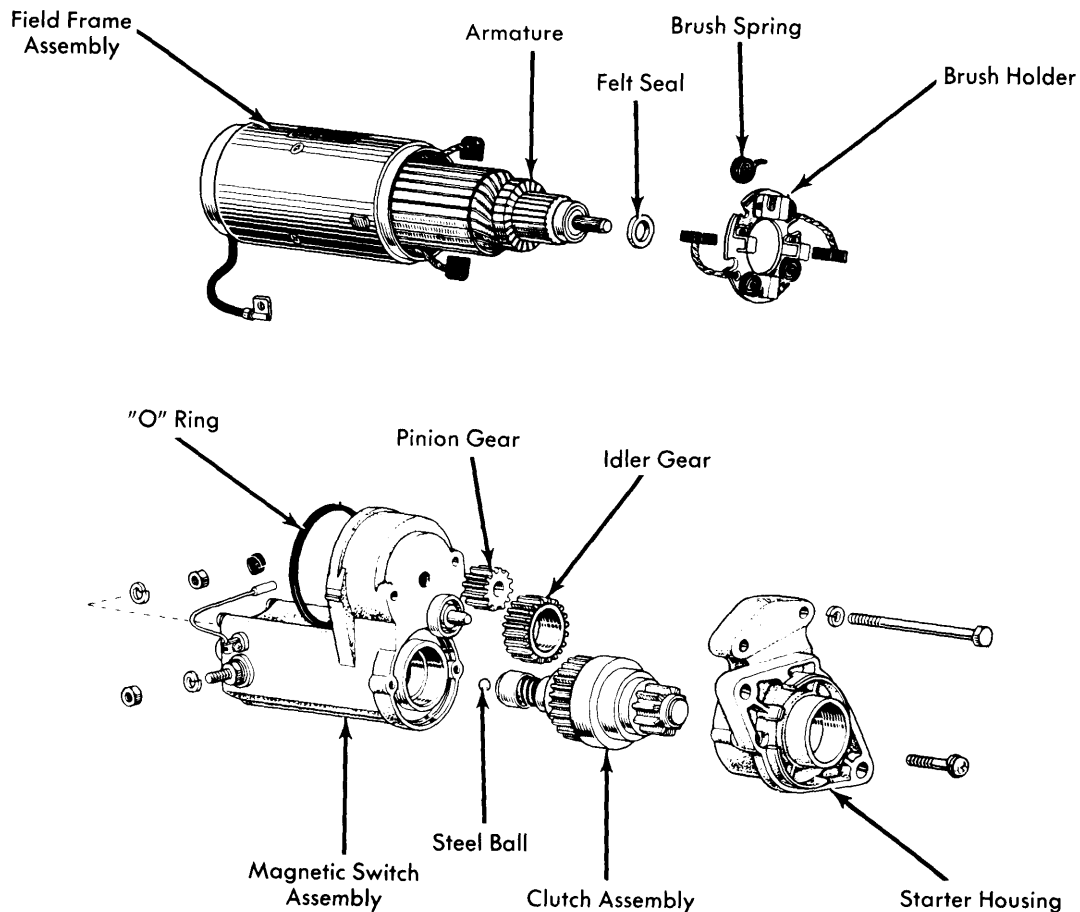

Fig. 4 Exploded View of Nippondenso Reduction Gear Starter (Toyota Model for 20R Engine Shown, Others Similar)