

NIPPONDENSO DIRECT DRIVE

Ford Courier
Subaru
Toyota

DESCRIPTION

The Nippondenso starter has four pole pieces and four sets of field coils. Four commutator brushes are installed; two are grounded, and two are insulated and are connected to the ends of field coils. Field coil is connected with armature coil through brushes and commutator segments in series. Starter clutch is engaged to armature shaft with helical splines. The turning of the pinion is due to these helical splines which result in a smooth engagement of pinion and flywheel.

APPLICATION

Model	Part No.
Ford Courier	ⓐD37Z-A
Subaru	
Man. Trans.	2970
Auto. Trans.	4210
Toyota	
4M Engine	41020
F Engine	60060
2F Engine	60061
20R Engine	
Federal	36050
Calif.	33020

ⓐ — Ford part number.

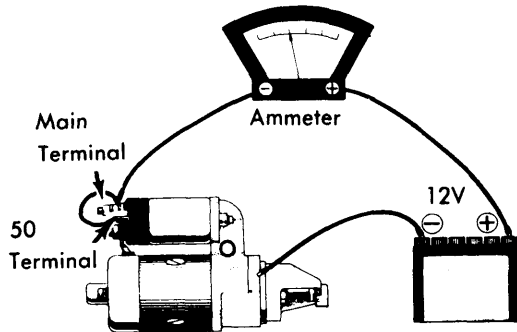

Fig. 1 Circuit for No Load Test

TESTING

PERFORMANCE TESTS

No Load Test — With starter on bench, and using a fully charged 12-volt battery, make connections as shown. The starter should rotate smoothly. See specification chart for RPM, voltage, and current draw.

Lock Test — To perform lock test follow instructions and procedures outlined in instruction manual furnished with tester. With starter locked in test stand, and voltage adjusted to specified figure, ammeter reading and starter torque should be within limits (see specifications).

OVERHAUL

DISASSEMBLY

- 1) Disconnect field coil wire from starter solenoid main terminal and remove the two solenoid attaching bolts. Remove solenoid by moving it up and down to unhook unit from drive lever.
- 2) Remove bearing cover and pull out armature shaft lock plate, washer, seal and spring.
- 3) Remove through bolts, commutator end frame, brush holder and yoke.
- 4) Remove drive lever set bolt, rubber piece, plate, armature and drive lever from housing.
- 5) Remove pinion stop collar from armature shaft end, and remove starter clutch.

PARTS REPLACEMENT & TESTING

Armature — Check armature for open, shorted or grounded circuits. Inspect armature shaft for bend; if bend is excessive replace armature. *NOTE* — Do not attempt to straighten a bent shaft. Inspect armature shaft to bushing clearance. If clearance exceeds .008", replace bushing.

Commutator — If condition warrants, carefully polish commutator with a strip of fine glass paper. If surface is scored, rough or burnt, dress with lathe just enough to remove defective area. If out-of-round exceeds .012", commutator must be turned. After turning, out-of-round must not exceed .004". Check mica depth and file off mica if depth is less than .008". Correct depth is .020-.032".

STARTER PERFORMANCE SPECIFICATIONS					
Model	No Load Test ⓐ		Lock Test		
	Amps.	RPM	Amps.	Volts	Torque
Ford Courier Subaru Toyota	below 50 below 50	5000+ 5000+ below 470 7.7 over 9.4 ft. lbs.
4M Engine F Engine 2F Engine 20R Engine	below 50 below 45 below 50 below 50	5000+ 3500+ 5000+ 5000+	below 550 below 430	7.0 7.3	over 10 ft. lbs over 10.5 ft. lbs

ⓐ — At 11 volts.

Starters

NIPPONDENSO DIRECT DRIVE (Cont.)

Brushes & Springs - 1) Check brush holder insulation. Connect one lead of ammeter to brush holder positive side and other lead to negative side of brush holder. If tester needle moves, the brush holder is shorted due to defective insulator. Replace brush holder.

2) Check brush length and if less than .51" (Toyota 2F engine) or .47" (all others), replace brushes. Be sure brushes move freely in holders and if movement is sluggish, clean brushes and holders.

3) Check brush spring tension and if less than 21 ozs. replace springs. New brush springs should have a tension of 37-48 ozs.

Starter Solenoid - Test pull-in motion of solenoid by connecting test leads to the "50" terminal and the main "F" terminal. Apply 8 volts. Plunger should be pulled in. If switch does not pull in, it is defective. Disconnect the "F" terminal lead only. If plunger remains pulled in, then switch is satisfactory. Test plunger returning movement by connecting the battery positive lead to the "F" terminal and the negative lead to the switch body. Depress plunger by hand and release it. If plunger returns to its original position with 12 volts, switch is satisfactory.

Field Coils - Check field coils for open circuit using a circuit tester. Connect one test prod to field coil lead and the other prod to soldered portion of brush lead. If meter does not

register, field coil is open. Repair or replace as necessary. Check field for ground by connecting one test prod to field coil and other lead to starter housing. If meter registers, coil is grounded. Remove field coil and repair or replace as necessary.

REASSEMBLY

Clean all parts and coat the sliding surface of armature shaft splines, starter clutch bushing, drive lever and moving stud with multipurpose grease. Reassemble in the reverse order of disassembly while noting the following: After completing reassembly, operate starter under a no load condition and check clearance between pinion gear and pinion stop collar. If clearance is not within specifications, adjust length of solenoid plunger shaft. Standard length of shaft is 1.34". To increase clearance, lengthen plunger. To decrease clearance, shorten plunger length.

Pinion Gear Clearance

Application	Clearance
Ford Courier08-.16"
Subaru04-.20"
Toyota	
F Engine04-.12"
4M Engine01-.16"
2F & 20R Engines008-.16"

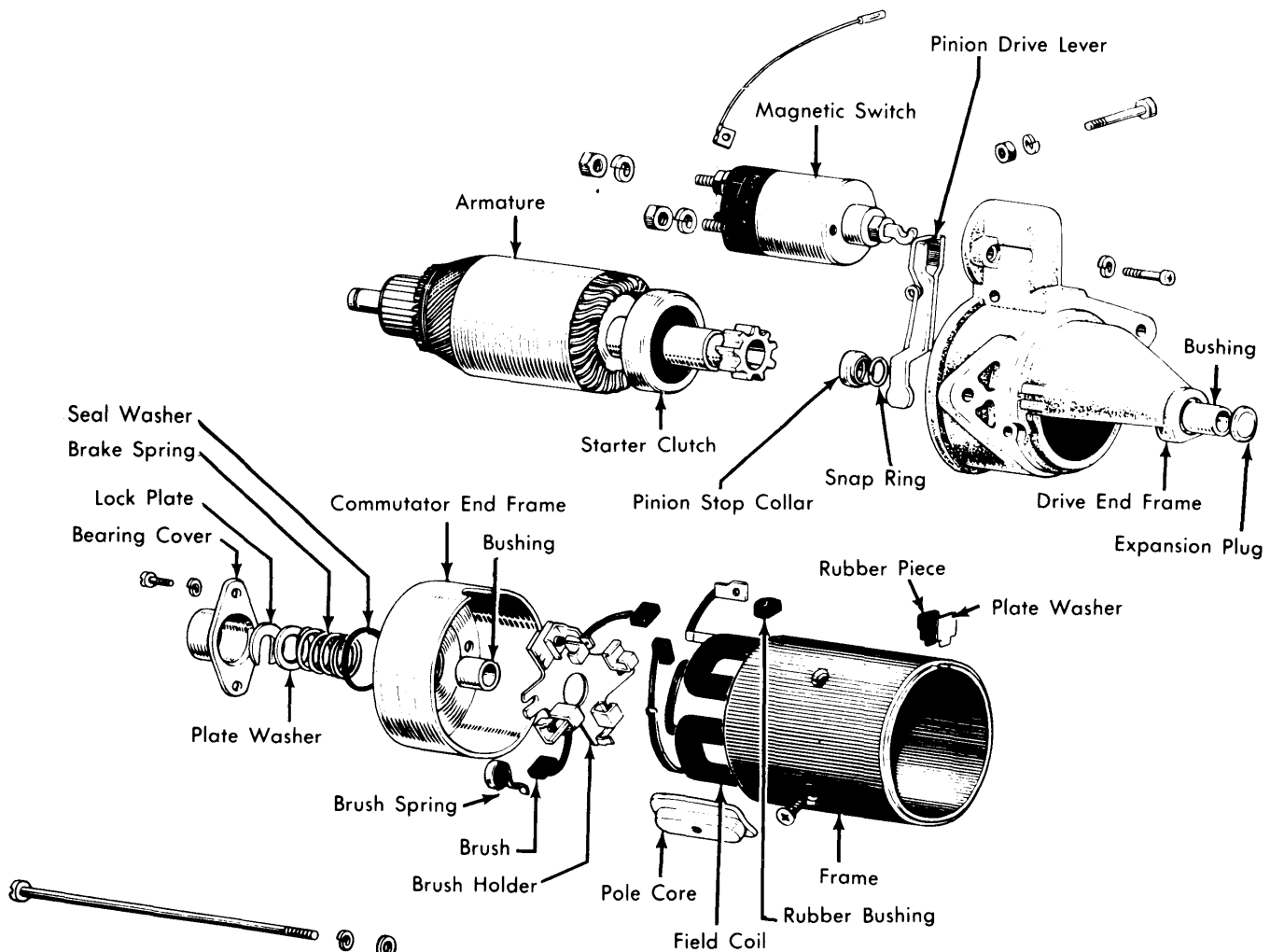

Fig. 2 Disassembled View of Starter Motor