

Starters

FIAT

Fiat, All Models

DESCRIPTION

Fiat starter is a 12 volt system with four poles and field windings are in series. Overrunning clutch pinion drive mounted directly on armature shaft. Pinion drive and battery connection to starter motor are controlled by a solenoid mounted on starter frame.

Starter Application

Model Application	Fiat No.
128 & X1/9 Models	E 84-0.8/12
124 & 131 Models	E 100-1.3/12

TESTING

PERFORMANCE TESTS

Cranking Amperage Draw — Mount starter on starter test stand. Make wiring connections as shown in illustration. Starter test stand should have a ring gear and a brake dynamometer. Ring gear should have minimum pinion/ring ratio of 1.0-10. If test stand is not equipped with correct pinion/ring ratio, follow manufacturers instructions in use of test stand. Test should be made with ambient temperature of 77°F. Observe amperage draw, voltage reading, and delivered torque while operating starter and check against specifications.

No Load Test — With starter mounted on test stand so pinion cannot contact ring gear, operate starter. Amperage draw, voltage reading and armature RPM should be within specifications.

Stall (Lock) Test — With starter mounted in test stand and ring gear locked, adjust test stand rheostat to values specified (see specifications) and observe torque on dial indicator.

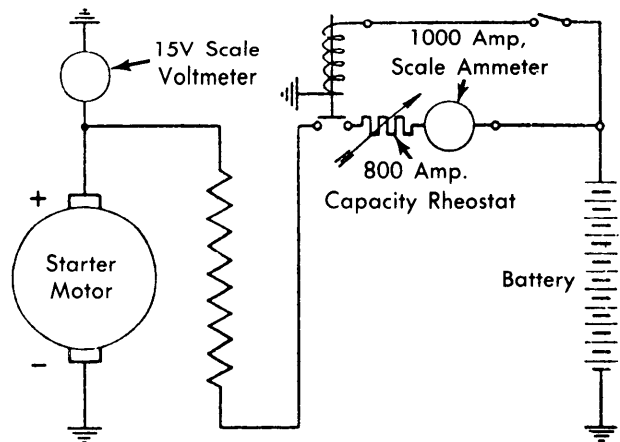

Fig. 1 Performance Test Wiring Diagram

Cranking Amperage Draw

Starter No.	Amps @ RPM	Torque (Ft. Lbs.)
E 84-0.8/12	170@1950±100①	2.89±.14
E 100-1.3/12	280@1600±100②	5.87±.14

① — At 10.3 volts.

② — At 9.5 volts.

Brush Spring Tension — E 84-0.8/12 — 2.5-2.9 lbs. (1.15-1.3 kg); E 100-1.3/12 — 2.2±.2 lbs. (1±0.1 kg).

Rotation (Pinion End) — Clockwise.

Armature End Play — E 84-0.8/12 — .0039-.0197" (0.1-0.5 mm); E 100-1.3/12 — .003-.027" (0.07-0.70 mm).

STARTER PERFORMANCE SPECIFICATIONS					
Model	No Load Test ①		Lock Test		
	Amps.	RPM	Amps.	Volts	Torque (Ft. Lbs.)
E 84-0.8/12 E 100-1.3/12	Below 35 Below 28	7000±500 5200±500	370 530	8.3±0.3 7±0.3	7.9±.36 12.58±.7

① — At 12 volts.

OVERHAUL

DISASSEMBLY

The starter motor can be disassembled into the following components: Solenoid, commutator end plate, frame (containing field coils and pole pieces), armature, overrunning clutch and pinion drive gear, and pinion end housing.

1) With the metal band (brush cover) removed from starter frame, disconnect lead from solenoid terminal and remove nuts from rod attaching solenoid to pinion end head of the motor and remove solenoid.

2) Disconnect positive brush holder (insulated). Lift brushes and arrange ends of brush springs against sides of brushes to hold them off commutator.

FIAT (Cont.)

3) Remove nuts on tie-rods of the two supports, and remove brush holder bracket. Be careful not to lose thrust washers (one fibre, and one steel) on the pin.

4) Slide frame off pinion end. Take out split pin from engaging lever pivot and remove pivot.

5) The armature and thrust washers can be taken out with drive and fork lever. Remove the snap ring from armature shaft and remove drive parts in their proper order.

CLEANING

Do not immerse starter components in solvent. Use compressed air to blow dirt and worn brush dust from field coils and armature. Use cleaning brush dipped in solvent to clean drive unit, then blow dry with air.

PARTS REPLACEMENT

Field Coils — Mount starter frame in press-type screwdriver stand and remove pole piece attaching screws. Remove pole pieces and field coils. Prior to installing new coils, heat windings to 122°F in order to obtain added flexibility and facilitate seating the coils under pole shoes. Use press-type screwdriver stand to completely tighten attaching screws. After installation is completed, measure pole shoes inner diameter. To assure proper air gap between pole shoes and armature,

inner diameter must be between 2.175-2.182" (55.25-55.42 mm) on starter No. E 84-0.8/12 and between 2.675-2.677" (67.95-68.00 mm) on starter No. E 100-1.3/12. Do not bore out inner diameter to obtain specified diameter. If diameter is not within tolerance, coils and shoes have been improperly installed.

REASSEMBLY

Lubricate inner splined face of drive assembly with SAE 10 motor oil before installing drive on armature shaft. Reverse disassembly procedure to complete overhaul.

TROUBLE SHOOTING & DIAGNOSIS

Starter Inoperative — Battery terminals corroded. Starter switch or battery terminals loose. Battery discharged or defective. Worn brushes (not contacting commutator). Starter switch (solenoid) contacts burned or worn. Commutator segment dislodged by centrifugal force.

Starter Operation Sluggish — Worn brushes. Part of field or armature windings shorted. Poor battery cable connections. Battery charge low, or defective cell.

Starter Motor Noisy — Worn armature shaft bushing. Pinion gear disengagement exceptionally late (worn or defective overrunning clutch).

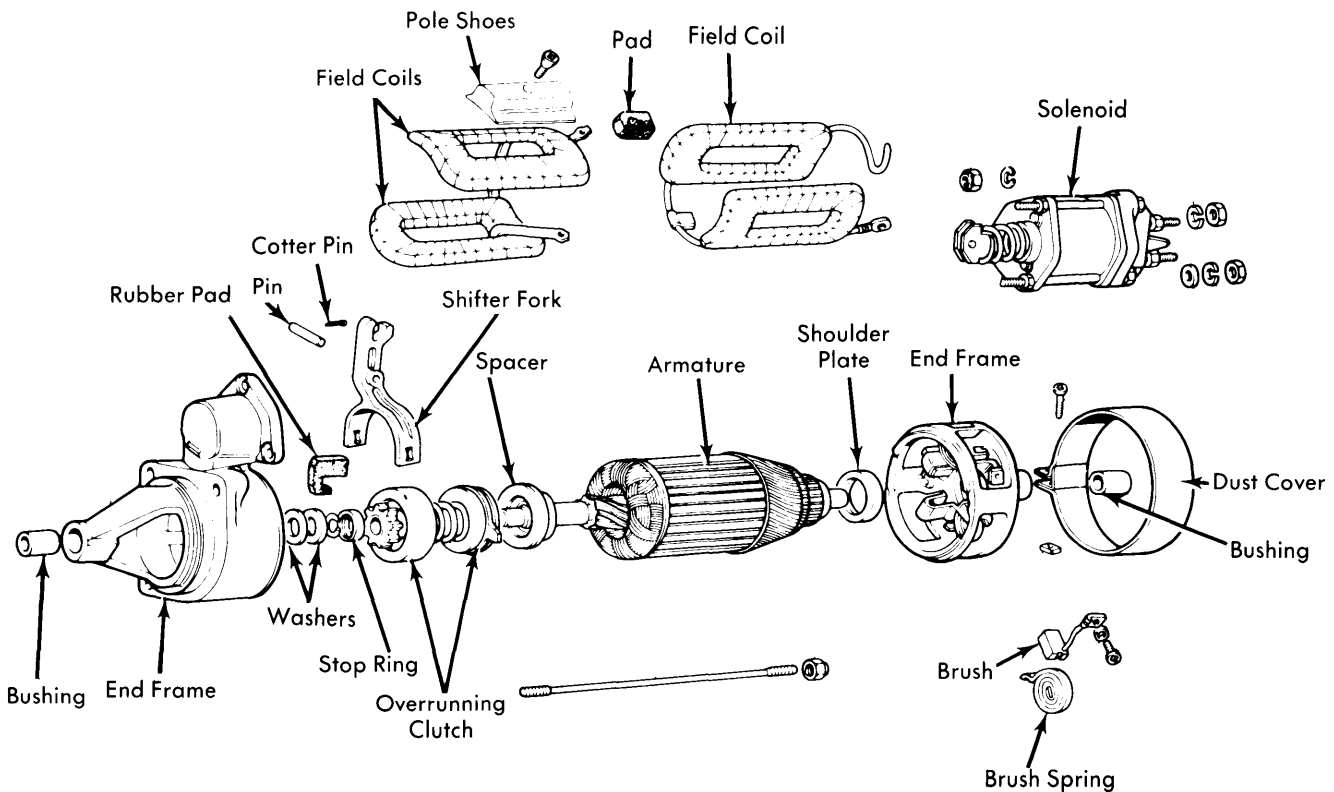

Fig. 2 Disassembled View of Fiat Starter Motor