

MARELLI

Fiat
All Models

APPLICATION

► CHANGES, CAUTIONS, CORRECTIONS

► **ELECTRICAL SYSTEM REPAIRING CAUTION** — Reversed polarity or excessive voltage will result in extensive damage to alternator system. Note the following to prevent damage:

Battery Installation — Negative battery terminal must be connected to ground (negative ground systems only), and positive terminal connected to starter. DO NOT reverse battery leads.

Battery Charging — If a Quick Charger is used, both battery cables must be disconnected from battery. DO NOT use a Quick Charger to provide starting voltage.

Circuit Interruption — The battery must never be disconnected while alternator is running.

Alternator Removal — Always disconnect battery ground before alternator removal and replacement.

High Voltage — DO NOT use a high voltage source to test diodes.

Booster Battery (For Engine Start) — Booster battery must be connected with negative lead to negative terminal and positive lead to positive terminal. DO NOT reverse battery leads.

DESCRIPTION

Marelli alternators are conventional three-phase, self-rectifying type alternators. Six silicone rectifier diodes are connected to form a full-wave, three phase rectifying bridge. The three negative rectifier diodes are pressed directly in the end frame. Three positive diodes are located in a heat sink which is insulated from the end frame. The 60 amp. alternator models also have three energizing diodes pressed into a support assembly.

Model	Fiat No.
124	A 12M 124/12/42M
128	A124/14V/60A
131 & X1/9	
W/O Air Conditioning	A 124/14V/44A
W/Air Conditioning	A 124/14V/60A

TROUBLE SHOOTING

INDICATOR LIGHT ON WITH IGNITION SWITCH IN OFF POSITION

Output current and voltage will be slightly lower than specifications. One or more positive diodes are shorted.

INDICATOR LIGHT ON AT LOW RPM

Stator winding has a phase open.

NO OUTPUT VOLTAGE

Rotor winding is open.

INDICATOR LIGHT ON WITH ENGINE RUNNING

One or more negative and energizing diodes shorted.

HIGH OUTPUT VOLTAGE

One energizing diode open. Improper operation of voltage regulator.

INDICATOR LIGHT GLOWS DIMLY WITH KEY ON OR ENGINE RUNNING

Faulty connection in ignition system. Brushes stuck in housing or worn excessively.

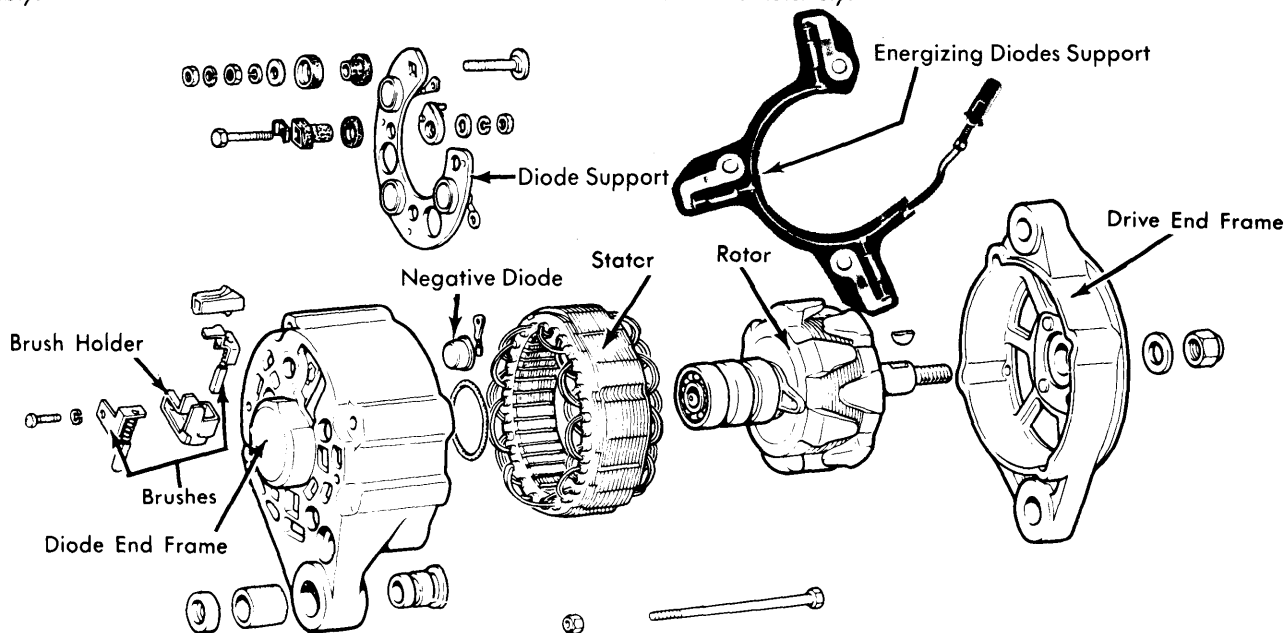

Fig. 1 Disassembled View of Marelli Alternator (the A 124/14V/60A type is shown)

MARELLI (Cont.)

TESTING

BENCH TESTING

Rotor Field Winding Resistance – Connect ohmmeter leads to terminal 67 of alternator and to a good ground. If resistance is not within specifications, rotor field winding is open.

Stator Phase Winding Resistance (A 124/14V/44A only) – Use an ohmmeter to check the resistance across each phase of armature winding. Resistance should be almost zero. If resistance is high, an open exists in one of the windings.

Diode Checks – 1) Connect leads of an ohmmeter to terminal 30 and stator winding connector. Check resistance, then reverse leads and recheck. Both readings should show high resistance with one reading being slightly higher than the other. If both readings are low, a positive diode is bad.

2) Check resistance between ground and stator winding connector. Reverse leads and check reading. If both readings are low, a negative diode is bad.

3) Check resistance between energizing diode plug and stator winding connector. Reverse leads and check reading. If both readings are low, an energizing diode is bad.



Fig. 2 MARELLI Alternator Test Points

OVERHAUL

DISASSEMBLY

- 1) Remove drive and ventilation components from rotor shaft. Remove brush holder (with brushes) by backing out its mounting screw on diode end head. Remove Woodruff key on shaft.
- 2) Unscrew nuts of the four through bolts, remove drive end frame and rotor. Before removing stator, unscrew from inside (of housing), three nuts securing stator winding phase ends to diode ends. Remove stator.
- 3) To disassemble diode end frame, unscrew the nut of terminal "30". The frame with negative diodes and the support with positive diodes will thus be separated.

TESTING

Stator Winding Resistance – With stator disassembled from alternator and leads disconnected, connect ohmmeter probes between each pair of stator leads. Ohmmeter must show equal readings for each pair of stator leads. Replace stator if readings are not equal.

Rotor Winding Resistance – Rotor resistance can be checked with an ohmmeter. Connect leads across slip rings at 68°F (see specifications).

Brushes – The spring pressure on slip ring brushes should be about one pound (0.43 kg), with new brushes in operation position.

PARTS REPLACEMENT

Brushes – To ensure best results, brushes should be replaced with a new brush holder as a complete assembly. Before installing holder assembly, clean all parts of grease and carbon dust, lubricate bearings with suitable grease (Fiat MR 3).

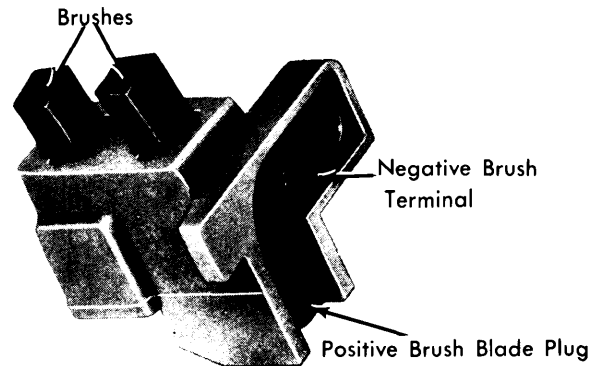

Fig. 3 Brush Holder Assembly

REASSEMBLY

The alternator is reassembled by reversing the order of disassembly procedure.

SPECIFICATIONS

Application	Test Data
Cut-In Speed @12V (68°F)	1000±50 RPM
Current Output @14V	
A 124/14V/60A	60 amps. min.
All Others	44 amps. min.
Maximum Output Current	
A 124/14V/60A	70 amps.
All Others	53 amps.
Maximum Continuous Alt. RPM	13,000
Field Winding Resistance @68°F	
A 124/14V/60A	2.6±.05 ohms
All Others	4.3±.2 ohms