

HITACHI

Datsun
Chevrolet LUV
Subaru

SPECIFICATIONS

Output@2500 Alternator RPM

Alternator	Amps ^①	Volts
LT135-13B	28	14
LT135-19B	28	14
LT135-26	28	14
LT150-13	37.5	14
LT150-19	37.5	14
LT150-21	40	14
LT160-23	42	14

① - Minimum.

Nominal Output

LT135-13B	35	12
LT135-19B	35	12
LT135-26	35	12
LT150-13	50	12
LT150-19	50	12
LT150-21	50	12
LT160-23	60	12

Resistance Values (Ohms)

Alternator	Stator Coil	Rotor Coil
LT135-13B	0.17	4.4
LT135-19B	0.17	4.4
LT135-26	0.13	4.3
LT150-13	0.17	4.4
LT150-19	0.17	4.4
LT150-21		
LT160-23	0.17	4.4

TESTING

NOTE - Some testing is described as part of Overhaul procedure in this article. The following testing is performed with alternator on the vehicle.

ALTERNATOR SPEED TEST

Datsun Models - Ensure battery has a full charge, then connect a 30-volt voltmeter as shown in illustration, and test as follows:

1) Detach connectors at alternator. Connect a test probe from voltmeter positive terminal to "N" or "BAT" terminal. Connect other test probe to ground. Check that voltmeter registers battery voltage.

► CHANGES, CAUTIONS, CORRECTIONS

► **BATTERY INSTALLATION, BATTERY CHARGING, OR USING A BOOSTER BATTERY FOR ENGINE START** - Reversed polarity or excessive voltage will result in extensive damage to alternator system. Note the following to prevent damage:

Battery Installation - Negative battery terminal must be connected to ground. Positive terminal must be connected to starter lead. DO NOT reverse battery leads.

Battery Charging - If a Quick Charger is used, both battery cables must be disconnected from the battery. DO NOT use a Quick Charger to provide starting voltage.

Booster Battery (For Engine Start) - Booster battery must be connected with negative lead to negative battery terminal and positive lead to positive battery terminal. DO NOT reverse battery leads.

DESCRIPTION

Hitachi alternators are conventional three-phase, self-rectifying type alternators. Six diodes (three positive and three negative) are used to rectify current.

APPLICATION

Model	Hitachi No.
Datsun	
B210	LT150-19
610 & 710	LT150-13
280Z	LT160-23
620 Pickup	
W/O Air Conditioning	LT135-13B
W/Air Conditioning	LT135-19B
Chevrolet LUV	LT135-26
Subaru	LT150-21

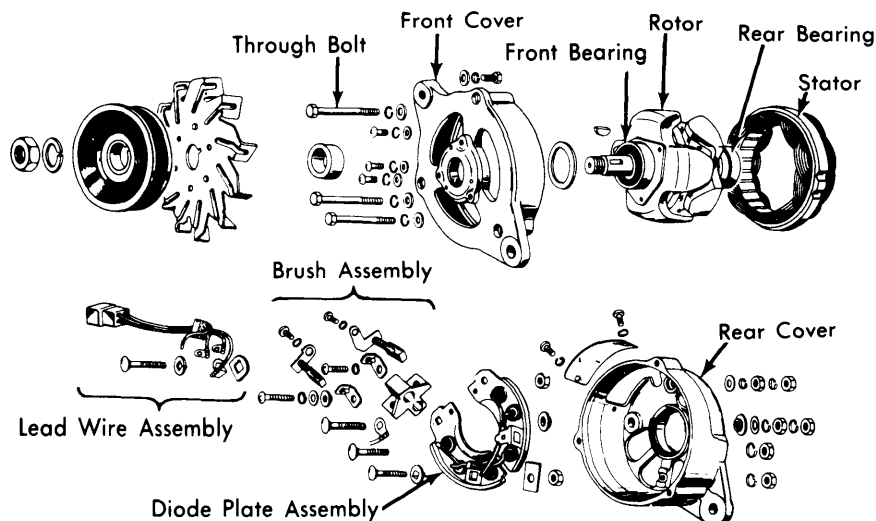

Fig. 1 Disassembled View of Hitachi Alternator

HITACHI (Cont.)

2) Turn on headlights to high beam. Start engine and increase speed to approximately 1000 RPM and observe voltmeter. If voltmeter registers below 12.5 volts, alternator is defective. If above 12.5 volts, alternator is good.

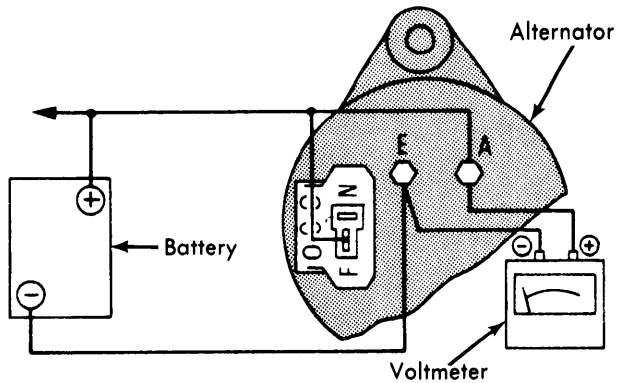

Fig. 2 Alternator Testing Connections for Datsun

Subaru Models – 1) Connect a voltmeter and leads to battery as shown in Fig. 3. Operate the alternator and turn off the switch "SW" when alternator speed reaches approximately 800 RPM. Increase speed in small increments while watching voltmeter deflection and read alternator speed when at 14 volts. Speed should be approximately 1000 RPM.

2) Make test connections using a 30-50 ampere variable resistor, battery, ammeter, and voltmeter as shown in Fig. 4. Operate alternator with switch "SW-1" closed. When alternator speed reaches approximately 800 RPM, set the variable resistor to maximum and turn on switch "SW-2". Increase alternator speed while maintaining a constant 14 volts by adjusting resistance. Read current at 2500 RPM and 5000 RPM. Readings should be 37-43 amperes at 2500 RPM and 48-54 at 5000 RPM.

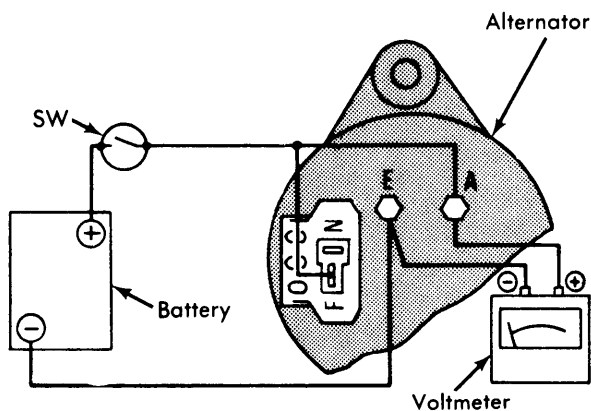

Fig. 3 Alternator Testing Connections for Subaru

RESISTANCE & CONTINUITY TESTING

All Models – 1) Measure resistance, using an ohmmeter, across "F" and "E" terminals for rotor coil resistance. Rotor coil circuit is normal if resistance is 4-5 ohms. If resistance is high, there is poor contact between brushes and commutator. If no continuity exists between "F" and "E" terminals, there is either an open rotor coil circuit, brush sticking or a broken lead wire. If resistance is low, it indicates a rotor coil layer short or grounded circuit.

2) **NOTE** – The following test will not indicate a open state of the diodes. Tester will indicate a continuity regardless of diode conditions if tester leads are connected to the terminals with polarities reversed. Connect positive lead of tester to alternator "N" terminal and tester negative lead to alternator "A" terminal. If continuity is observed on the tester, there exists one or more shorted positive diodes.

3) Next, connect tester positive lead to alternator "E" terminal and tester negative lead to alternator "N" terminal. If continuity is present, it indicates that one or more of the negative diodes are shorted.

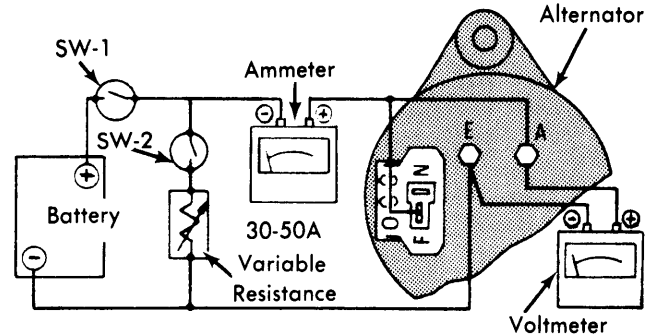

Fig. 4 Alternator Output Test Connections for Subaru

OVERHAUL

DISASSEMBLY

1) Remove nut and take out pulley, fan, and washers. Pull out spacer. Remove screws securing brush holder and brush holder cover. Withdraw brush and brush holder. **NOTE** – Leave "N" lead wire connected to stator coil lead.

2) Unscrew through bolts and separate front and rear housings. Remove three set screws from bearing retainer and separate rotor from front cover. Pull rear bearing from rotor assembly, if replacement is necessary.

3) Remove diode cover and disconnect stator coil lead wire from diode terminal, using a soldering iron. Remove the diode assembly by unscrewing the terminal nut and diode-setting nuts. Remove stator from rear cover.

INSPECTION & REPAIR

Rotor – Apply tester probes to slip rings of rotor. If ohm reading is within specifications, rotor conduction is satisfactory. If not, a disconnection of field coil may exist. Next, apply probes to slip ring and rotor core, to check ground. If conduction exists, replace rotor assembly.

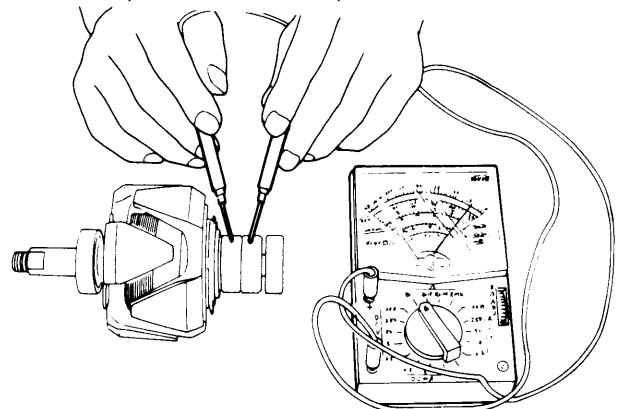

Fig. 5 Rotor Field Coil Conduction Test

HITACHI (Cont.)

Stator— The stator is normal when there is conduction between individual stator coil terminals. When there is no conduction between terminals, cable is broken; replace stator assembly. If each lead wire of stator coil (including neutral wire) is not conductive with stator core, condition is satisfactory. If conduction exists, stator is grounded and must be replaced.

Diodes — 1) Perform a conduction test on all diodes, in both directions, using an ohmmeter. Test the conduction between each terminal and plate. Diode installed on "+" plate is a positive diode which allows current to flow from terminal to "+" plate only; current does not flow from "+" plate to the terminal. A diode installed on the "-" plate is a negative diode and allows current to flow from the "-" plate to the terminal only; current does not flow from the terminal to the "-" plate.

2) If current flows in both directions, the diode is short-circuited. If current does not flow in either direction, the diode is open. If any diode is defective, replace the entire diode assembly (individual diodes are not serviceable).

Brushes & Brush Springs — Inspect movement of brushes for smoothness. Clean brush holder if necessary. Check brushes for cracks and wear. Replace if beyond limits shown. Check brush spring for corrosion and damage. Determine if springs exhibit proper tension. Test brush holder for continuity between each holder; replace if continuity exists.

Brush & Spring Data

Alternator	Brush Wear Limit	Spring Pressure
LT135-13B	.31"(7.5 mm)	9-12.2 oz.
LT135-19B	.31"(7.5 mm)	9-12.2 oz.
LT135-26	.28"(7.0 mm)	9-12.2 oz.
LT150-13	.31"(7.5 mm)	9-12.2 oz.
LT150-19	.31"(7.5 mm)	9-12.2 oz.
LT150-21	.28"(7.0 mm)	9-12.2 oz.
LT160-23	.31"(7.5 mm)	9-12.2 oz.

⊙ — Measure with .08" (2 mm) protrusion from brush holder.

Brush Wear Limit Lines

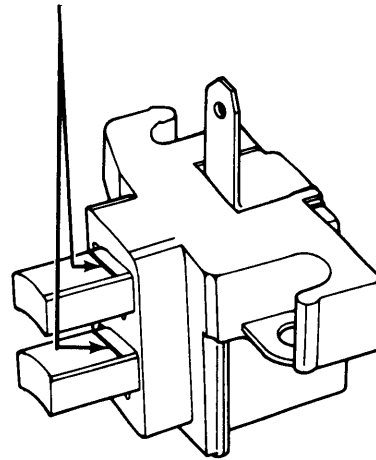

Fig. 6 View of Assembled Brushes

REASSEMBLY

Reinstall diode assembly and stator to rear cover. Connect lead wires of stator coil to terminals of diode assembly. **NOTE** — Solder quickly to avoid damage to diodes. Reinstall diode cover. Reinstall rotor to front cover. Place assembly in vise and replace pulley and components. Insert and tighten housing through bolts. Assemble brushes to brush holder and insert holder into alternator. Perform, as previously described.