

Starter Controls

HITACHI & MITSUBISHI

DESCRIPTION

The starter solenoid is mounted directly to the starter yoke (gear case). Current flows through "Series" (Pull-in) and "Shunt" (Hold-in) coils to excite the solenoid. A plunger, inside the solenoid is pulled into the solenoid, in turn pulling the shift lever that engages the starter pinion gear with the engine flywheel ring gear. When the contacts of the solenoid close, the starter cranks the engine and the pull-in coil is cut out. The magnetic force of the hold-in coil holds the plunger in until the engine starts. When the ignition is switched from START to ON, the starting current is broken and the pull-in coil demagnetizes the hold-in coil and the plunger returns to its original position.

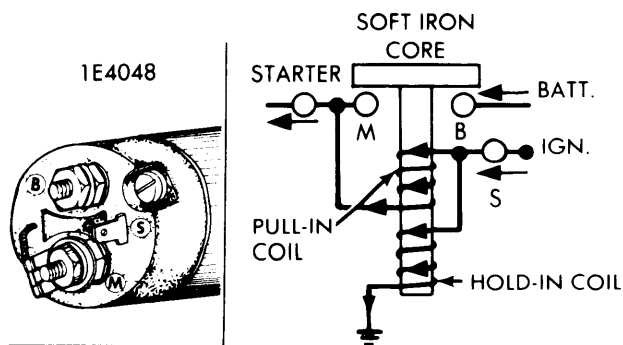

STARTING CIRCUIT DIAGRAM
AND SOLENOID TERMINALS

TESTING

Clean solenoid plunger and sleeve with fine sand paper and alcohol and blow off with air before performing tests.

NOTE — Make tests with solenoid removed from starter, or remove starter to solenoid lead before testing.

Pull-in Coil Test — Using a 12 volt battery, connect a jumper wire between the negative battery post and the "S" terminal. Connect a second jumper to the positive battery post, and just touch the "M" (MT) terminal. Plunger should pull-in immediately.

Hold-in Coil Test — Connect a ground lead between the "M" (MT) terminal and the solenoid case. Apply 8 volts to the "S" terminal, this will pull-in the plunger. Disconnect lead to "M" (MT) terminal and the plunger should remain held in.

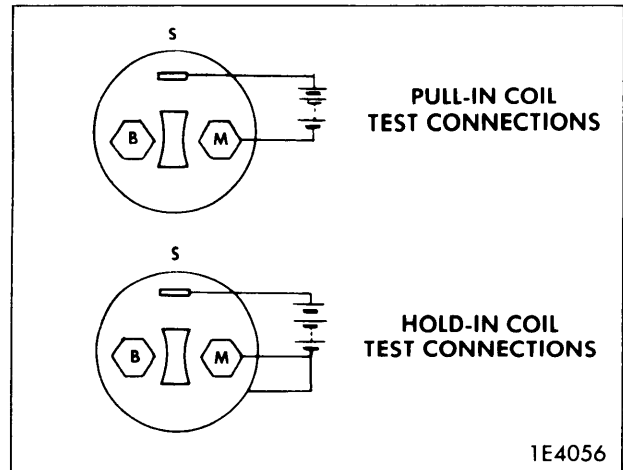

Return Test — Push plunger into solenoid by hand. Apply 12 volts between the "M" (MT) terminal and the solenoid case. If solenoid case is short circuited the plunger will be attracted. If nothing happens, the solenoid is satisfactory.

Pinion Gear Clearance — The clearance between the pinion gear and stop collar should be .012-.059" on Hitachi and .02-.08" on Mitsubishi. This is adjusted by placing shims between solenoid and starter yoke except on Hitachi starter S 114 87L. On starter S 114 87L, depress switch plunger and measure distance between adjusting nut and solenoid switch cover. If not within specifications (1.248-1.272"), adjust by loosening nut and turning plunger until measurement is within specifications.