

## BOSCH

Volkswagen

### DESCRIPTION

A two-unit regulator is used consisting of a voltage regulator and a cutout relay. The voltage regulator consists of a two stage unit operating on a double set of contacts. A regulating element of semi-conductive material, called a "variode", is incorporated in the unit. This variode senses temperature variations arising from the intensity of the charging current and ambient temperature.

**CAUTION** — Before putting generator and regulator into operation, they must be polarized. To polarize generator, momentarily contact lead from positive post of battery to "D+" terminal on regulator (with belt removed). Never polarize by connecting terminal "B+" (on regulator) to terminal "D+" on regulator. Damage may result to regulator, cutout and generator.

### APPLICATION

<b>Car Model</b>	<b>Bosch No.</b>
'The Thing'.....	0 190 350 068

### TESTING

#### CUTOUT RELAY

**CAUTION** — "D+" terminals on regulator and generator must not be disconnected with engine running as field windings on generator will burn out.

1) Disconnect "D+" lead from generator. Connect a 15-0-15 amp ammeter between lead and "D+" terminal. Connect ammeter positive terminal to generator and negative terminal to disconnected lead.

2) Start engine and allow to run at fast idle. Reduce idle until ammeter moves to negative range (see specifications). Turn engine off. Ammeter must jump back to zero before engine comes to a complete stop. If ammeter does not return to zero, cutout relay is defective and regulator must be replaced or adjusted.

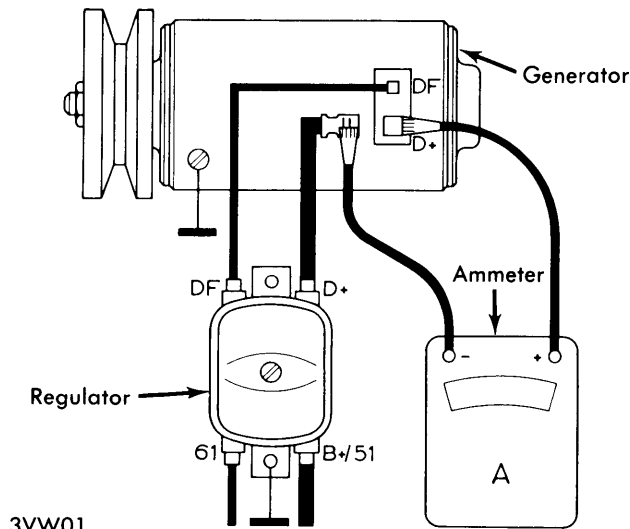

3VW01

CUTOUT RELAY TEST HOOKUP

#### VOLTAGE REGULATOR

This test requires the use of 0-30 volt voltmeter, a 10-0-50 amp ammeter and a rheostat than can be loaded to 50 amps. Use a minimum of 9 AWG wire for test connections.

- 1) Connect leads to regulator terminal "B+/51" and connect voltmeter, ammeter and rheostat as shown in illustration.
- 2) Start engine and increase speed to about 3000 RPM. Adjust rheostat to proper load setting (see specifications). Read regulating voltage and compare to specifications. Adjust or replaced regulator if voltage is not to specifications.

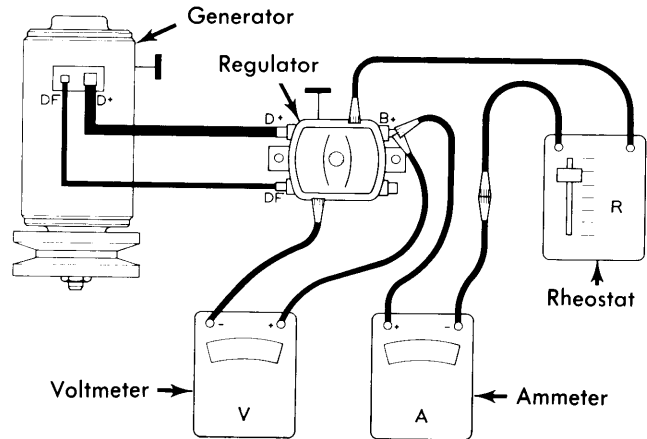

3VW02

VOLTAGE REGULATOR TEST HOOKUP

### ADJUSTMENTS

#### CUTOUT RELAY

1) With armature in cut-in position, adjust bending of spring to "a", .008-.020" (.20-.51 mm), by bending bracket "C". See illustration.

2) With armature in cut-out position, adjust gap "b" to .015-.047" (.38-1.19 mm) by bending "B" (stationary relay point). The necessary pressure "c" for closing the points has to be 4.22 oz. (119.6 gm). See illustration.

3) Adjust the cut-in voltage by bending bracket "C". If further adjustment is needed, bend stop "D". To increase the reverse current, decrease clearance "a" by bending "B" and vice versa.

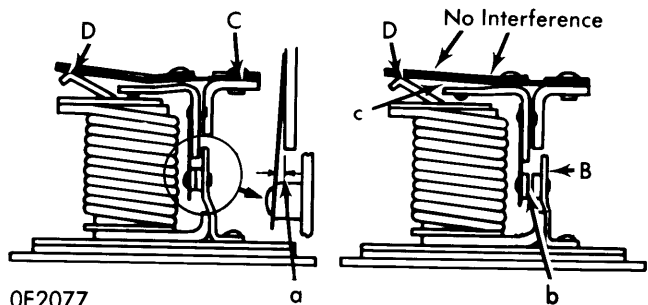

0E2077

CUTOUT RELAY ADJUSTMENT

## BOSCH

### VOLTAGE REGULATOR

1) With armature in cut-out position, bend "C" for clearance "a", .031-.051" (.79-1.30 mm). Bend "B" (upper stationary contact) for clearance "b" of .010-.015" (.25-.38mm). See illustration.

2) With armature in cut-in position, check clearance "c". It should be .012" (.31 mm) minimum. Clearance "d" is .008" (.20 mm) minimum. Spring "e" should bend .008-.023" (.20-.58 mm).

3) Adjust regulating voltage at idle by bending up stop "D" to achieve a higher reading and down to achieve a lower reading.

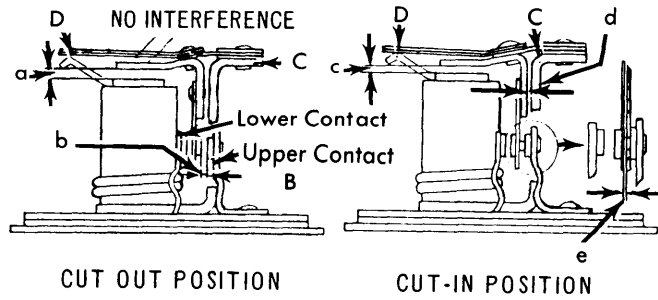

VOLTAGE REGULATOR ADJUSTMENT

OE2080

REGULATOR SPECIFICATIONS					
Part Number	Cutout Relay		Regulating Voltage	Current Regulator Setting	
	Cut-In Voltage	Reverse Current Amps.	At Idle Volts	Cold Amps.	Hot Amps.
0 190 350 068	12.4-13.1	2.0-7.5	12.8-13.8	.....	45