

## HONDA

Honda Civic (1973)

### DESCRIPTION

Starter is a 12-volt, four pole, series wound unit. Magnetic switch assembly is mounted on gear case. Starters have an overrunning clutch connected by a shift lever to magnetic switch plunger. Brushes and springs are retained inside yoke assembly by a holder.

### APPLICATION

**Model**

Honda Civic (1973).....

**Honda Part No.**

31200-634-670

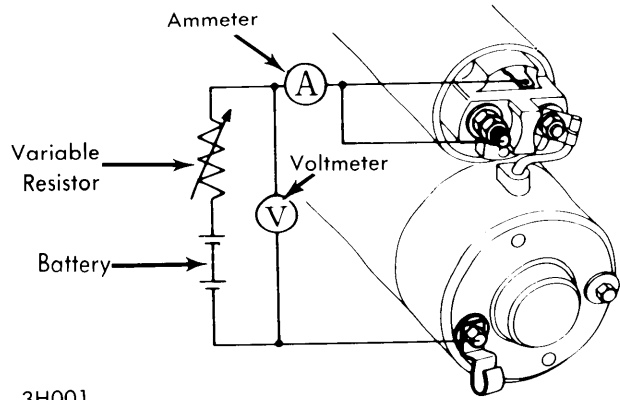

**NO LOAD TEST HOOK-UP  
OVERHAUL**

### TESTING

#### PERFORMANCE TESTS

**No Load Test** — Using a fully charged 12-volt battery, connect voltmeter and ammeter as shown. Compare readings with specifications.

**Lock (Torque) Test** — Mount starter in a test stand to allow starter torque measurement (follow manufacturers instructions). With voltage adjusted (see specifications), ammeter reading and starter torque should be within specifications.

#### DISASSEMBLY

- 1) Remove magnetic switch by loosening attaching bolts. Remove rear dust cover with a screwdriver and remove "E" clip and thrust washer. Remove brush holder plate retaining screws.
- 2) Remove through bolts. Lightly tap rear cover with a mallet and remove cover. Remove gear case. Remove bushes from commutator and remove armature. Remove brushes from holders and separate holders from yoke. Remove pinion gear from armature by pulling clutch stop collar toward pinion and then removing stop clip.

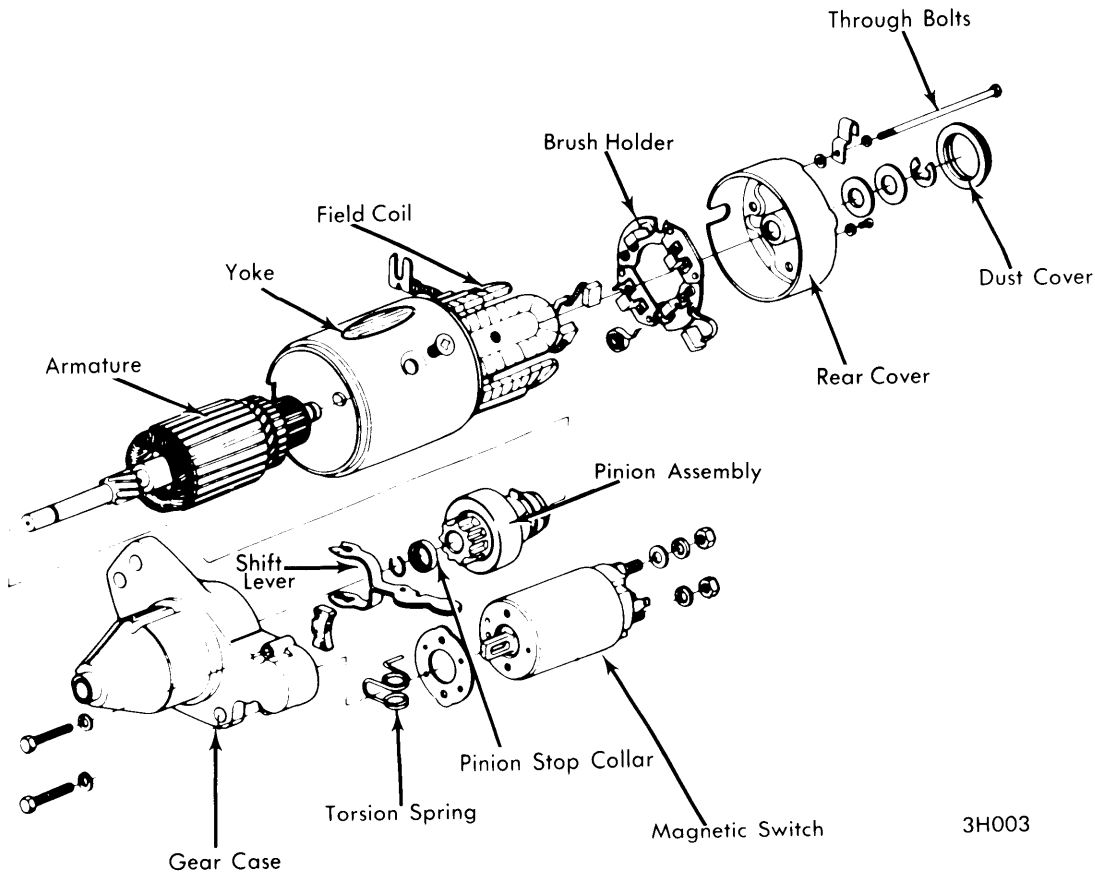

3H003

### HONDA STARTER

## HONDA (Cont.)

## PARTS REPLACEMENT &amp; TESTING

**Brushes & Springs** — Using a suitable spring scale, measure pull on brush spring. If tension is below specifications, replace spring. Measure brush length. Replace brush if worn beyond specifications. When installing a new brush, polish it with #500 or #600 emery paper. Also check brush holder for a short circuit.

**Brush Spring Tension** — 3.52 lbs. (1.6 kg).

**Brush Length** — .1575" (4 mm).

**Armature** — Using an ohmmeter, check for continuity between commutator and armature shaft. If continuity exists, replace armature. Place armature on a growler and rotate it slowly while holding a steel strip over armature. If strip vibrates, replace armature.

**Commutator** — Check commutator surface for contamination or wear. If surface is dirty, clean with #500 or #600 emery paper. If wear is within specifications, undercut mica, if necessary, with a hacksaw blade to specifications.

**Minimum Commutator Diameter** — 1.26" (32 mm).

**Mica Undercut** — .008" (.2 mm).

**Field Coil** — Using an ohmmeter, check for continuity between field coil terminals and coil brushes. If no continuity exists, replace coils. Next check for continuity between one terminal of coil and the yoke. If continuity exists, replace coil.

**Overrunning Clutch Assembly** — Move clutch along shaft. If there is any sign of binding, or if clutch slips when armature is rotated and pinion gear held, replace pinion. Also check pinion gear teeth for wear or damage and replace if necessary.

**Magnetic Switch Assembly** — Using an ohmmeter, make sure continuity exists between switch terminal "S" and coil case. Replace switch if an open circuit is indicated. Also test for continuity between switch terminal "S" and "M". If no continuity exists, replace switch.

## REASSEMBLY

To reassemble, reverse disassembly procedure. Use new clips during reassembly and make sure shift lever is installed in proper direction. After reassembly, check pinion-to-stopper clearance with pinion moved out by magnetic switch. If clearance is not to specifications, adjust by changing thickness plate which comes in two sizes, .016" (.4 mm) and .031" (.8 mm).

**Pinion-to-Stopper Clearance** — .012-.059" (.3-1.5 mm).

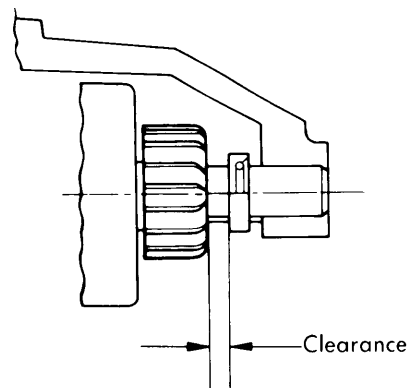

3H002

PINION-TO-STOPPER CLEARANCE

STARTER PERFORMANCE SPECIFICATIONS					
Model	No Load Test		Lock Test		
	Amps.	RPM	Amps.	Volts	Torque
31200-634-670	below 70	7000	below 380	4.9	over 5.42 ft. lbs.