

## NIPPONDENSO

Toyota (1965-73)

### DESCRIPTION

Toyota uses two types of regulators, a single element type and a two element type. Two element types consists of a voltage regulator and voltage relay. Single element type has a voltage regulator only.

### APPLICATION

Engine	Part No.
KC (1969-70)	22010
3K-C (1970-73)	22010
2T-C (1971-73)	22010
8R-C (1969-71)	33010
18R-C (1972-73)	33010
3R-B (1965-67)	
1900 Sedan	31011
Crown	
Prior to Eng. 3R 479894	40020
After Eng. 3R 479894	40021
Corona	
Prior to Eng. 3R 479894	31010
After Eng. 3R 479894	31011
3R-C (1968-70)	
Prior to 10/68	31011
After 10/68	31010
M (1965-68)	40021
2M (1968-71)	
Prior to 11-68	41010
After 11/68	41011
4M	
1971-72	41012
1973	33010
F (1965-73)	
FJ 40 (1965-72) ②	40010
FJ 55 (1970-72)	33010
All 1973 Models	40011

- ① - All part numbers start with 27700 prefix.
- ② - Eng. numbers F224280 thru F279664 use part number 27700 40011.

### TESTING

#### VOLTAGE REGULATOR

Connect tests meters to voltage regulator circuit as shown in illustrations. Vary alternator RPM and check voltmeter reading. Increase alternator RPM and check voltage when ammeter registers 1/2 of maximum rated alternator output. Voltage should be 13.8-14.8 volts. Adjust alternator speed to 3,000 RPM, voltage output should again be 13.8-14.8 volts. If voltage is not within specified range, adjust voltage regulator by bending arm to obtain correct setting.

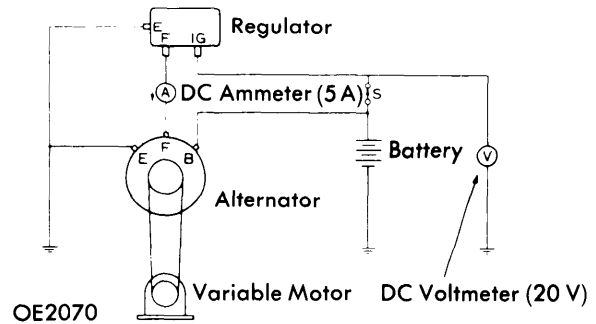

SINGLE ELEMENT TYPE TEST CIRCUIT

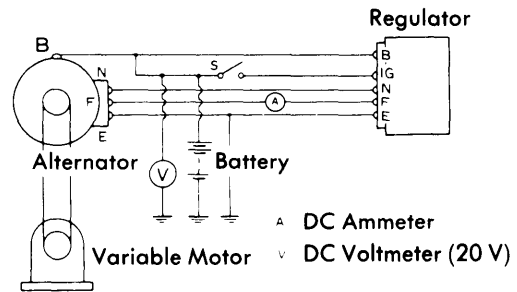

TWO ELEMENT TYPE TEST CIRCUIT

#### VOLTAGE RELAY

**Charge Warning Lamp Type** - Connect tests meters as shown in illustration. Increase alternator RPM gradually and note voltage when charge warning lamp goes out. Cut-in voltage should be 4.5-5.8 volts. If voltage is not as specified, bend voltage relay adjusting arm to obtain correct setting.

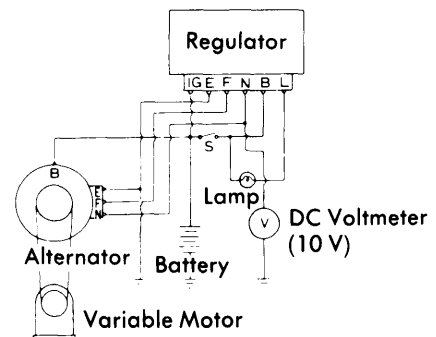

OE2071

#### RELAY - WARNING LAMP TYPE TEST CIRCUIT

**Ammeter Type** - Connect tests meters as shown in illustration. Increase alternator RPM gradually and note voltage. Voltage should be 4.5-5.8 volts, if necessary, adjust voltage by bending adjusting arm.

## NIPPONDENSO (Cont.)

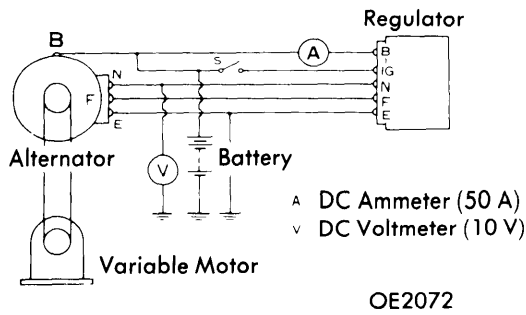

OE2072

### RELAY - AMMETER TYPE TEST CIRCUIT

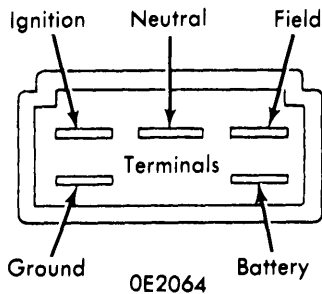

OE2064

### TERMINAL POSITION FOR TWO ELEMENT TYPE REGULATOR WIRING CONNECTOR

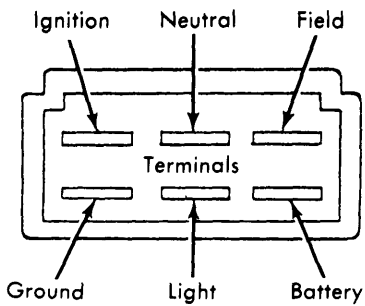

OE2065

### TERMINAL POSITION FOR TWO ELEMENT REGULATOR WITH WARNING LAMP CIRCUIT

### ADJUSTMENT

*NOTE - Adjustments are not applicable to sealed units. If points are slightly oxidized or pitted, dress contacts with suitable emery cloth (about 400 grit). If points are oxidized or pitted excessively, replace regulator assembly.*

### VOLTAGE RELAY

**Contact Spring Deflection** - Press on armature and use a feeler gauge to check clearance between armature and point spring. Clearance should be .008-.018" (.20-45 mm). Adjust by bending point holder "A" on relay unit.

**Point Gap** - Check point gap with a feeler gauge. Specified point gap is .016-.047" (.4-1.2 mm), if necessary, adjust by bending point holder "B".

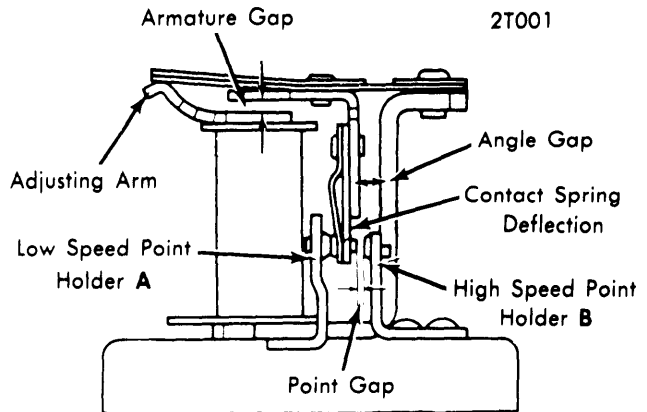

VOLTAGE REGULATOR

### VOLTAGE REGULATOR

**Armature Gap** - Check with a feeler gauge, specified clearance is .024-.032" (.6-8 mm). adjust by bending point holder "A".

**Point Gap** - Specified point gap is .010-.018" (.25-.45 mm). Adjust gap by bending spring holder "B".

**Contact Spring Deflection** - With armature depressed, check spring deflection with a feeler gauge. Specified deflection should be .008-.024" (.2-6 mm). If deflection is not as specified, replace regulator assembly.

**Angle Gap** - With armature depressed, check gap with a feeler gauge (see illustration). Specified gap is .008" (.20 mm).

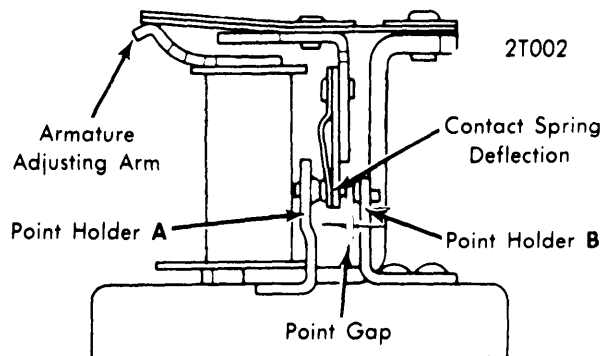

VOLTAGE RELAY