

## HITACHI (HONDA)

Honda (1971-72)

Application	Hitachi Part No.
AN600 Sedan.....	LD 130-03 (USA)
AN600B Sedan.....	LD 130-03 (USA)
AZ600 Coupe.....	LD 130-03 (USA)

### ► CHANGES, CAUTIONS & CORRECTIONS

► **BATTERY INSTALLATION, BATTERY CHARGING, OR USING A BOOSTER BATTERY TO START ENGINE CAUTION** – Reversed polarity or excessive voltage will result in extensive damage to alternator system. **NOTE** the following to prevent damage:

**Battery Installation** – Negative battery terminal must be connected to **ground**. Positive terminal must be connected to starter lead. *Do not reverse battery leads.*

**Battery Charging** – If a “Fast Charger” is used, both of the car’s battery cables must be disconnected from battery. *Do not use “Fast Charger” to provide starting voltage.*

**Booster Battery (Used To Start Engine)** – Booster Battery must be connected with negative lead to negative terminal of battery and positive lead to positive terminal of battery. *Do not reverse battery leads.*

### DESCRIPTION

The alternator is installed on the right side of the engine. The alternator rotor unit is a part of the flywheel and ring gear assembly which is mounted on the right end of the crankshaft. The alternator stator is installed in the flywheel housing. A separate rectifier, using silicon diodes, is installed at the right front bumper support and connected to alternator with lead wires.

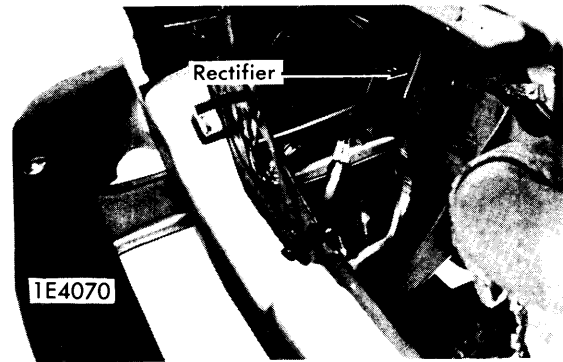

RECTIFIER LOCATION

### SPECIFICATIONS

#### Alternator

Type.....	LD 130-03 (USA)
Operating Speed.....	1,200-7,500 RPM
Rated Speed.....	5,000 RPM
14V Speed (Normal Temp.).....	1,200 RPM (or Less)
Output Speed.....	5,000 RPM
Output Voltage.....	14V
Output Current.....	35A (or More)

#### Rectifier

Type.....	SB 6B-8A (USA)
Output.....	12V, 40A
Connection.....	3-Phase, Bridge

**Stator Coil Resistance**..... 0.115 Ohms

**Rotor Coil Resistance**..... 4.05 Ohms

**Minimum Brush Length**..... .276" (7.0 mm)

**Brush Spring Tension**..... .56 lb. (0.255 mm) min.  
 .76 lb. (0.345 mm) max.

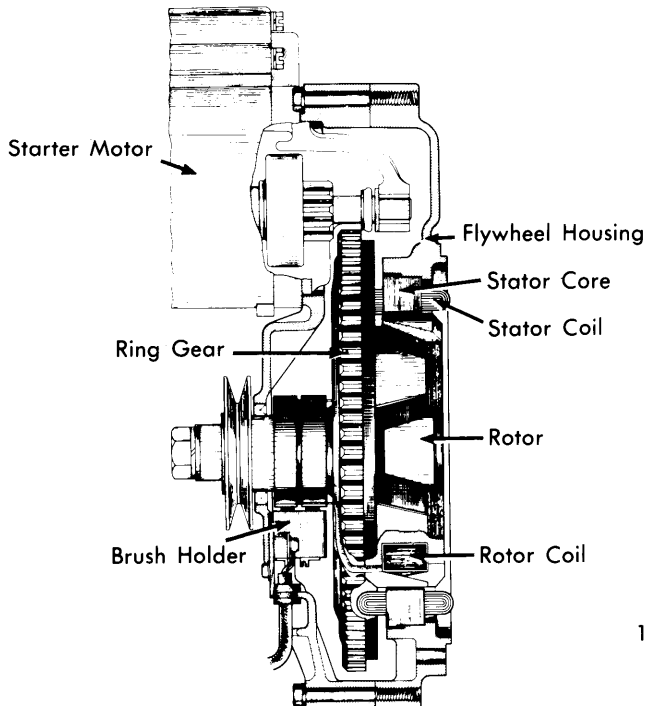

1E4071

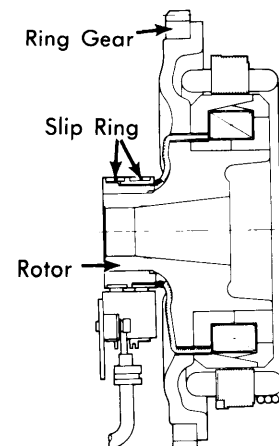

### HITACHI (HONDA) ALTERNATOR (TYPICAL)

# Alternators

## HITACHI (HONDA) (Cont.)

### REMOVAL

1) Disconnect battery ground cable. Identify (for reassembly) and disconnect white lead wires from rectifier, then disconnect the white with red stripe lead from black lead. Remove starter assembly. Remove fan belt from crankshaft pulley, then remove pulley.

2) Remove brush holder assembly. Remove flywheel housing cover bolts, then remove cover. To remove rotor, install a rotor holder (special tool) to keep rotor from turning. Then fully thread in a rotor remover (special tool), and tap rotor out, while lightly hammering head of rotor remover. *NOTE - Rotor is a taper fit to crankshaft.*

3) Stator is installed in flywheel housing. To remove, separate flywheel housing from engine after removing four bolts. Stator then may be lifted out after removing the three bolts and nuts holding it in place.

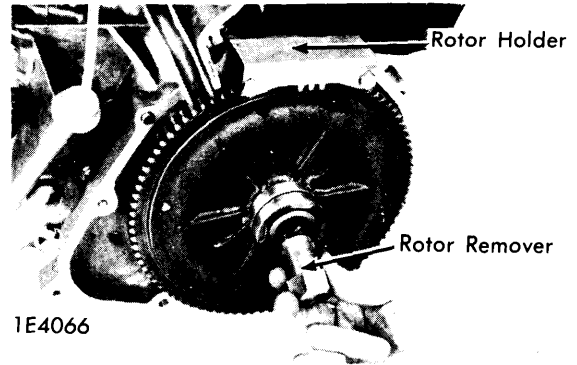

REMOVING ROTOR

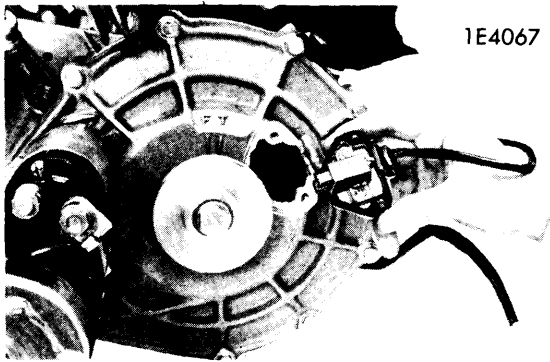

REMOVING BRUSH HOLDER

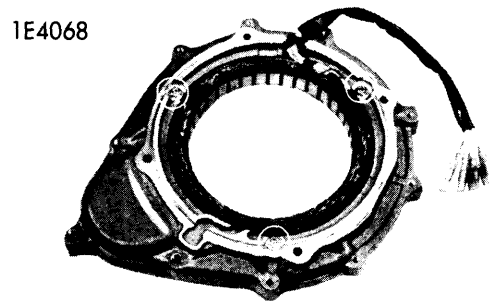

STATOR ASSEMBLY

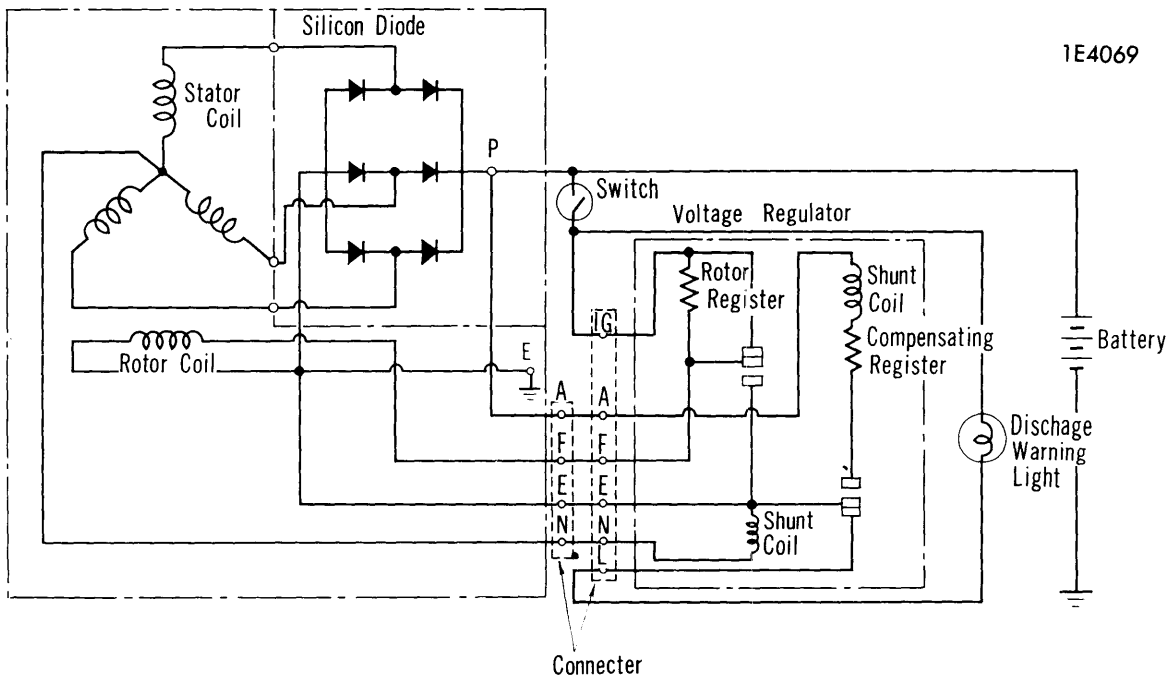

ALTERNATOR CIRCUIT (TYPICAL)

## HITACHI (HONDA) (Cont.)

### INSPECTION

1) Check rotor coil for disconnection and condition of insulation. Inspect continuity between the two slip rings using a suitable tester. No continuity indicates rotor coil is disconnected, and should be replaced. If continuity exists between slip rings and shaft, or core, the coil or slip rings are grounded, and should be replaced as required.

2) Alternator brush wear is normally minimal, however, if wear has reduced brush to minimum length specified, replace brush.

3) Using a suitable tester, check stator coil for insulation and disconnection. If no continuity exists between terminals, coil is disconnected and should be replaced. If there is continuity between stator coil terminals and flywheel housing or core, coil is grounded and should be replaced.

4) Inspect condition of brush and brush spring, and check also to see that brush slides smoothly in holder. To measure tension of brush spring, push in brush to depth corresponding to amount of brush wear plus .08" (2 mm). Check brush spring tension with suitable scale and compare reading with specification. *NOTE* — Length of new brush is .57" (14.5 mm).

5) Inspect rotor slip ring surface. If surface is stained or rough, refinish slip ring.

### INSTALLATION

Reinstall in reverse order of removal and note the following: When installing the flywheel housing cover, make sure that the two hollow pins (dowel pins) are installed in the housing. When installing the pulley, align pulley shaft pawl with the end notch of the crankshaft.

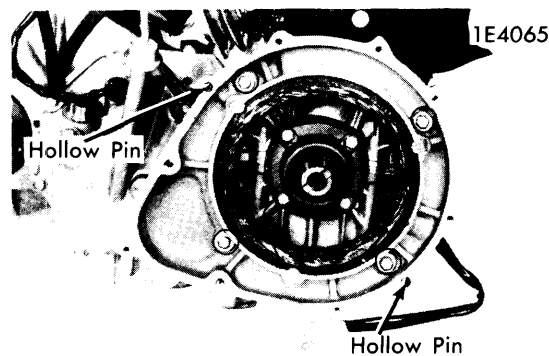

**DOWEL PIN LOCATION**