

BOSCH

Alfa Romeo (1969-73)
 Audi (1970-73)
 BMW (1963-73)
 Capri (1971-73)
 Fiat (1971-73)
 Mercedes Benz (1963-73)
 Opel (1966-73)
 Porsche (1966-73)
 Saab (1966-73)
 Volkswagen (1971-73)
 Volvo (1969-73)

► CHANGES, CAUTIONS, CORRECTIONS

► **BATTERY INSTALLATION, BATTERY CHARGING, OR USING A BOOSTER BATTERY TO START ENGINE** — Reversed polarity or excessive voltage will result in damage to alternator system. Note the following to prevent damage:

Battery Installation — Negative battery terminal must be connected to ground. Positive terminal must be connected to starter lead. DO NOT reverse battery leads.

Battery Charging — If a Quick Charger is used, both battery cables must be disconnected from the battery. DO NOT use a Quick Charger to provide starting voltage.

Booster Battery (For Engine Start) — Booster battery must be connected with negative lead to negative terminal of battery and positive lead to positive terminal of battery. DO NOT reverse battery leads.

APPLICATION

Model	Bosch Type Code	Bosch Part No.
ALFA ROMEO		
1750 (1969-71)	K1(R)14V 35A 20	400 553
2000 (1972)	K1(-)14V 45A 22	400 786
2000 (1973)	K1(-)14V 45A 22	400 848
AUDI		
S90 (1970-72)	K1(R)14V 35A 20	400 627
100LS (1970-72)	K1(R)14V 35A 20	400 670
100LS (1973)	K1(-)14V 55A 20	489 500
Fox (1973)	K1(-)14V 55A 20	489 520
BMW		
4 Cylinder Models		
1800 ti (1963-66) ...	K1(R)7V 50A 17	400 523
1600-2 (1967)	K1(R)14V 35A 20	400 631
1600 ti (1968-69) ..	K1(R)14V 35A 20	400 631
2000 (1966-69)	K1(R)14V 35A 20	400 555
2002 (1968-71)	K1(R)14V 35A 20	400 631
2002 (1972)	K1(-)14V 45A 22	400 768
2002 (1973)	K1(R)14V 45A 22	400 752
2002 tii (1972)	K1(-)14V 45A 22	400 795
2002 tii (1973)	K1(-)14V 45V 22	400 794
6 Cylinder Models		
All (Before 3/69) ...	K1(R)14V 35A 20	400 655
All (3/69-72)	K1(-)14V 45A 22	400 703
All (1973)	K1(-)14V 45A 22	400 702
CAPRI		
2000 (1971-73)	K1(R)14V 35A 20	400 758, 759, 806
2600 (1972)		400 006
2600 (1973)	K1(-)14V 35A 20	400 622
FIAT		
128 (1971-73)	G1(-)14V 33A 27	300 528, 558

APPLICATION (Cont.)

Model	Bosch Type Code	Bosch Part No.
MERCEDES BENZ		
4 Cylinder Diesel Models		
200D (1966)	K1(R)14V 35A 20	400 526, 537
200D (1967)	K1(R)14V 35A 20	400 607
200D (1968-72)	K1(R)14V 35A 20	400 611
4 Cylinder Carburetor Models		
200,220 (1965-73)	K1(R)14V 35A 20	400 611
6 Cylinder Carburetor Models		
230, 230S, 250S (1965-69)	K1(-)14V 35A 20	400 504
230/8, 250, 250/8, 250C, 280/S (1968-72) ..	K1(R)14V 35A 20	400 611
280, 280C (1973) ..	K1(R)14V 35A 20	489 526
6 Cylinder Fuel Injected Models		
280SE, 300SEL, (1966-72)	K1(-)14V 35A 20	400 634
All Others (1963-67)	K1(-)14V 35A 20	400 611
V8 Fuel Injected Models		
3.5 Engine (1969-71) ..	K1(-)14V 55A 20	400 716
4.5 Engine (1972) ..	K1(R)14V 55A 20	400 717
4.5 Engine (1973) ...	K1(-)14V 55A 20	400 716
OPEL		
Kadett (1966-70) ...	K1(R)14V 35A 20	400 526
Kadett 1900 (1968-72)	K1(-)14V 35A 20	400 620
GT1100 (60 HP) & GT1900 (90 HP) (1969-72)	K1(-)14V 35A 20	400 628
GT1900 & Manta (1971-73)	K1(-)14V 35A 20	400 620, 782
	K1(R)14V 45A 20	400 840
PORSCHE		
4 Cylinder Models		
914 (1970-72)	K1(RL)14V 50A 22	400 727
914 (1973)		Ⓣ022903023
6 Cylinder Models		
911, 911L, 911S (1966-68)	K1(RL)14V 35A 20	400 522
911E, 911T, 911S (1968-69 Early)	K1(-)14V 55A 20	400 665
911E, 911T, 911S (Late 1969-72)	K1(-)14V 55A 20	400 725
911E, 911T, 911S (1973) ..		Ⓣ91160311800
914/6 (1970-71)	K1(-)14V 55A 20	400 725
SAAB		
3 Cylinder Models		
95, 96, Monte Carlo (1966-68)	K1(L)14V 35A 20	400 615
Sonett II (1968-70) ..	K1(L)14V 35A 20	400 657
4 Cylinder Models		
99E (1970-73)	K1(R)14V 35A 20	400 728
	K1(R)14V 55A 20	400 764, 803 815, 849
All Others (1969-72)	K1(-)14V 35A 20	400 658
	K1(R)14V 55A 20	400 764, 803
All Others (1973)		Ⓣ8512378
V4 Models		
All Models (1967-72) ..	K1(L)14V 35A 20	400 615, 565
95, 96 (1973)	K1(-)14V 35A 20	400 656
Sonett (1973)	K1(L)14V 35A 20	400 657

BOSCH (Cont.)

APPLICATION (Cont.)

Model	Bosch Type Code	Bosch ①Part No.
VOLKSWAGEN		
Type 2 (1972-73)	K1(-)14V 55A 22	400 721
Type 4 (1971-73)	K1(-)14V 55A 20	400 719, 721
VOLVO		
P1800, 1800E/S (1972-73)	K1(R)14V 55A 20	400 756
All Others (1969-73)	K1(R)14V 35A 20	400 605

- ① — Basic part number is 0 120 (i.e. 0 120 400 611).
 ② — Porsche part number.
 ③ — Saab part number.

DESCRIPTION

Bosch alternators are conventional three-phase, self-rectifying type alternators. Nine rectifier diodes are connected to the stator windings (three to each phase lead). The diodes change the alternator A.C. voltages to D.C. voltages coming out of the "B+" and the "D+" terminals of the alternator.

ON-VEHICLE TESTING

NOTE — Off-vehicle testing is explained as part of Overhaul procedure in this article.

WIRING CONTINUITY TEST

Disconnect terminal plug from rear of alternator and connect a voltmeter negative terminal to ground. With ignition "ON", connect positive lead to each of the connector wires, in turn. Voltmeter should read battery voltage as each positive connection is made. If proper voltage is not read, trace each wire to find fault.

VOLTAGE DROP TEST — GROUND SIDE

Connect voltmeter between negative terminal of battery and alternator housing. Start engine and run at approximately 3000 RPM. If voltmeter reading exceeds .25 Volts, a high resistance in negative side of charging circuit is indicated. If so, check for loose, dirty, or corroded connections.

OUTPUT TEST

Disconnect terminal plug from rear of alternator and connect ammeter, in series, between alternator center terminal and corresponding socket in terminal plug. Also connect a jumper lead between the "D+" terminal and its corresponding socket in terminal plug. Start engine and run at approximately 3000 RPM. Turn on headlights and leave on for five minutes. Ammeter should read maximum alternator amperage at normal operating temperature.

REGULATOR CONTROL VOLTAGE TEST

Connect a voltmeter between main terminals of battery. Connect an ammeter, in series, between "B+" terminal of alternator and corresponding terminal of connector plug. Connect a jumper lead between alternator "D+" terminal and corresponding terminal of connector plug. Start engine and increase speed to approximately 3000 RPM. Run engine until

charging rate falls below 10 amps. The voltmeter should then read 14.1-14.4 Volts. If these readings are not obtained, replace regulator.

NOTE — The test cables should not be removed or the load excessively reduced during the testing procedure. Considerable load variations may damage the diodes. The control lamp should not go on at any time during the test.

OVERHAUL

DISASSEMBLY

NOTE — On 0 120 400 600 series alternators, lift carbon brushes with a hook and secure them, prior to disassembly (see illustration).

1) Remove nut, pulley, hub and key. Mark location of alternator in blower housing. Unscrew brush plate assembly and remove from alternator. Remove bolts from end frame, then remove frame and field rotor. Press rotor out of end frame. Press ball bearing off rotor. Remove insulating conduit from wires and cut wires as close to soldered joints as possible.

2) The diodes may be tested at this point, prior to further disassembly. Care should be exercised with insulating bushings under positive diode carrier. To remove negative carrier, extract threaded studs. When one rectifying diode has been damaged due to short circuiting, the three complementing diodes must be replaced also. Unscrew nuts on both "B+" terminal bolts and lift positive diode carrier (heat sink) up and back.

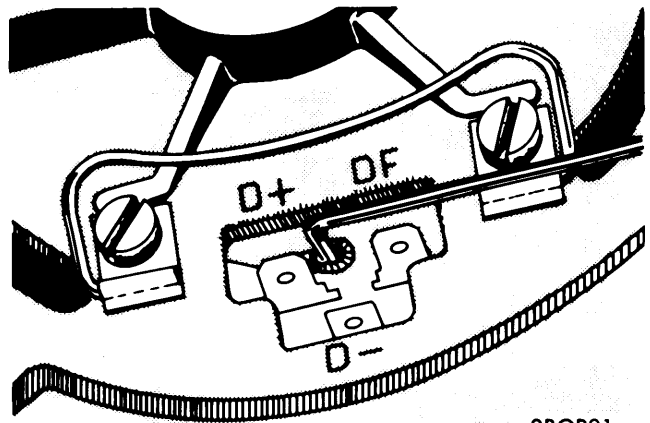

2BOP01

LIFTING CARBON BRUSHES
(0 120 400 600 SERIES)

TESTING & REPAIRING

Diode Assemblies — Test diodes with a suitable alternator tester (EFAW 192) before dismantling slip ring end frame further. **CAUTION** — Do not lay positive diode carrier on housing or false reading will be obtained. Disconnect conductor from "D+" to the exciter diodes at the exciter diodes heat sink. Unscrew spring and brush holder and remove from alternator. Unsolder stator lead and negative diode connections. Unscrew exciter diodes heat sink and remove together with positive diodes heat sink.

NOTE — Before further testing, lightly clean all components in gasoline or trichlorethylene, but do not soak.

BOSCH (Cont.)

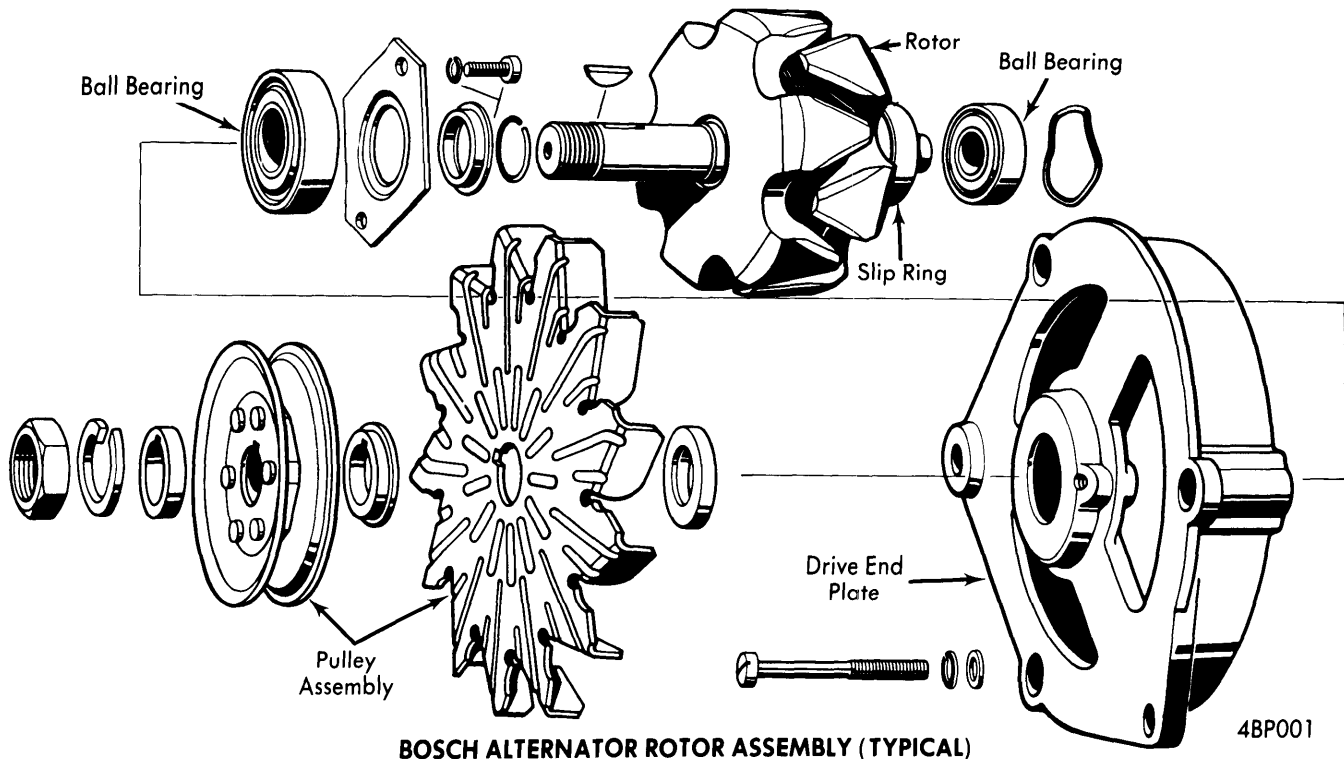

BOSCH ALTERNATOR ROTOR ASSEMBLY (TYPICAL)

Stator — Test stator for short circuits to ground, using suitable tester (EFAW 84). Test voltage should be 40V AC. Measure resistance of stator windings between phase connections. See *Specifications for proper value*.

Rotor — 1) Test claw pole rotor for short circuits to ground. Test voltage should be 40V AC. Measure resistance of exciter (field coil) in rotor with ohmmeter. See *Specifications for proper value*. Turn down slip rings on a lathe, using suitable tailstock chuck (EFAW 75 or GDF 85 R 3).

2) After turning, check concentricity of slip rings with dial gauge. Runout should not exceed .001" (.03 mm). Minimum diameter of slip rings may be 1.25" (31.5 mm). Maximum runout of pole wheel must not exceed .002" (.05 mm).

Diode Replacement — 1) On all except 0 120 400 600 series alternators, set diode plate on press die and force diodes out with plunger. Place diode plate (without diodes) onto suitable guide pilot (EFLJ 57/0/5) and set diode seat with suitable sleeve (EFLJ 57/0/3). Smear silicone oil on diode seat, place diode plate on press die and press diodes into position. After pressing in, test all diodes.

2) On 0 120 400 600 series alternators, set slip ring end frame on press die and force out defective diode. Coat diode seat with silicone oil and press in new diode. Test all diodes after replacement.

Drive End Frame — Check ball bearings for wear and replace as necessary. Lubricate bearings on one side. Press ball bearing into drive end frame with shielded side downward. Screw on retainer plate. Press ball bearing onto rotor (slip ring end), then press drive end frame onto rotor.

Carbon Brushes — Unsolder and replace carbon brushes. Do not allow solder to run into copper strands of brush leads. Minimum brush length is .55" (14 mm). After installation of new brushes, test for free movement.

2BOP02

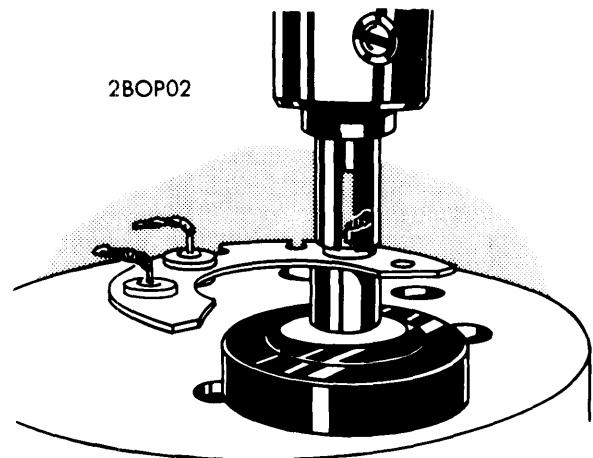

INSTALLATION OF DIODE

REASSEMBLY & TESTING

1) On all except 0 120 400 600 series alternators (steps 1 through 4), fit negative diodes heat sink and clamps. Screw in double end bolts (shorter threads outward). *NOTE* — *Left clamp is longer than right*. Replace insulating washers and bushings. Test terminal bolt "B+" for short circuit to ground. Test voltage should be 80V AC.

2) Position positive diodes heat sink (carrier) and secure with insulating and spring washers. *NOTE* — *Use insulating cap No. 1 120 502 000 instead of insulating washer on bolt next to terminal marked "D+/61"*. Tighten hex nuts.

3) Place stator in slip ring end frame. Draw positive and negative diode leads together and slip through an insulating sleeve. Push sleeve over lead of exciter diode and stator connection cable. Crimp a metal ring around end of leads and

Alternators

BOSCH (Cont.)

solder. Cut off any excess wire protruding through ring. Reposition wiring and attach in holding clamps.

4) Slide insulating sleeve over exciter diode terminal. Insulating sleeves of stator connection lead must project over edge of negative diodes heat sink. Clamp connections firmly.

5) On 0 120 400 600 series alternators (steps 5 through 7), test both "B+" terminal bolts for short circuit to ground. Test voltage should be 80V AC. Before fitting exciter diodes heat sink (carrier), solder three positive diode terminal leads onto heat sink from below.

6) After fitting exciter diodes heat sink, solder stator leads, negative and exciter diodes to the "COMB". **NOTE** - Use caution, do not overheat negative diodes. Install brush holder. Raise and secure carbon brushes before installing. Screw conductor "D+" onto exciter diodes heat sink.

7) Place wave spring washer into ball bearing fit. Rub ball bearing seat with suitable lubricant. Insert rotor with drive end bearing into slip ring end frame and secure with screws. Position positive diodes heat sink and secure. Springs are to be set onto carbon brushes by pressing on brush with a screwdriver. Brush springs pressure will seat brushes automatically.

8) Rub suitable lubricant into ball bearing seat of slip ring end frame. Install claw pole rotor with drive end frame. Check position of stator relative to end frame. Position brush holder plate. Tighten screws. Install fan belt pulley. Coat newly installed positive diodes with chlorinated rubber lacquer.

SPECIFICATIONS

Alternator output specifications are explained within the type designation code stamped on alternator.

K 1 (RL) 14V 35A 20

- K** - Diameter of Stator Frame:
 G - 3.94-4.29" (100-109 mm)
 J - 4.30-4.69" (110-119 mm)
 K - 4.70-5.48" (120-139 mm)
 Q - 5.49-6.66" (140-169 mm)
 T - 6.67-7.84" (170-199 mm)
 U - Over 7.85" (200 mm)
- 1** - Type of Alternator:
 1 - Claw-pole
 2 - Single-pole
 3 - Permeable-rotor
 4 - Claw-pole with exciter
- (RL)** - Direction of rotation:
 R - Right (Clockwise)
 L - Left (Counterclockwise)
 RL - Either Direction
 An arrow may also indicate direction of rotation.
- 14V** - Alternator operating voltage.
35A - Maximum current output in amperes.
20 - RPM in hundreds at $\frac{2}{3}$ of maximum current output (Rated Amp. Output)

Field Coil Resistance - 4.0 ohms + 10% measured at slip rings at normal ambient temperature.

Stator Windings Resistance - .2 ohms + 10% measured between the phase output terminals.

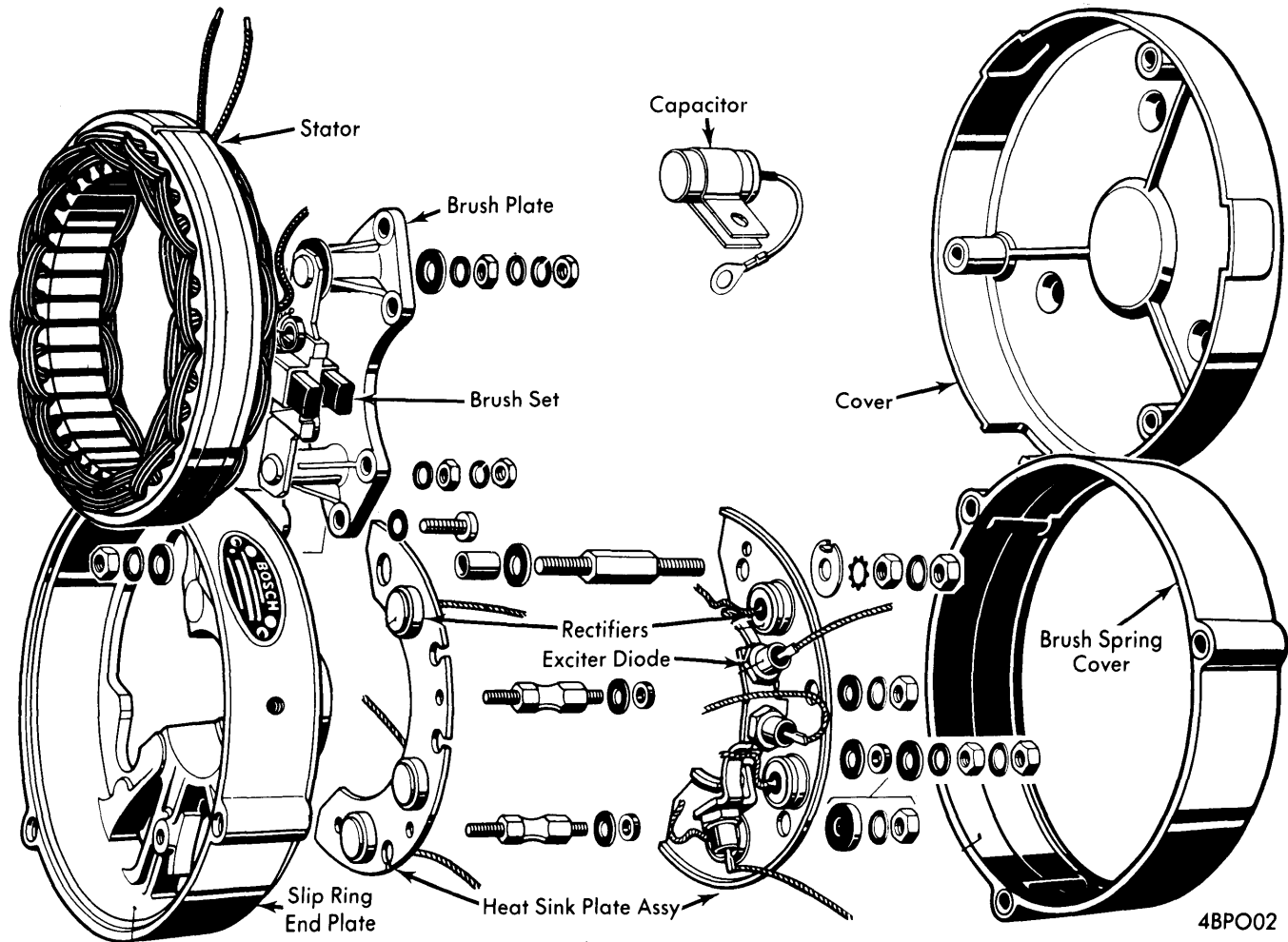

BOSCH ALTERNATOR FRAME ASSEMBLY (TYPICAL)

48PO02