

AMERICAN MOTORS MODEL 129

Eagle

DESCRIPTION

Eagle models are equipped with model 129 full-time 4-wheel drive transfer case. This unit provides fully differentiated 4-wheel drive under all operating conditions. The model 129 is a single range unit. Selection of 4-wheel drive is automatic and does not require any external linkage to achieve 4-wheel operation. Differentiated operation occurs through a coupling connected to an open differential. Torque is distributed to the front and rear propeller shafts through 2 drive sprockets and drive chain. Case assembly is cast aluminum. Case consists of front and rear halves and a rear retainer.

Eagles may be equipped with optional Select Drive system. Select Drive consists of a dash mounted switch, vacuum actuated shift lever in transfer case and vacuum actuated front axle disconnect. See *American Motors Front Drive Axle in this section*. Select Drive provides drive train selection appropriate for road conditions. Selection of "2-WD" mode activates transfer case shift lever to provide torque to rear propeller shaft only. Selection of "4-WD" mode activates transfer case shift lever to provide torque to both front and rear propeller shafts. See Fig. 1.

LUBRICATION

SERVICE INTERVAL

Check transfer case fluid level at first 5 month or 5,000 mile interval; then, every 7½ months or 7,500 miles. Change fluid every 12½ months or 12,500 miles.

FLUID TYPE

Use Dexron II automatic transmission fluid or equivalent.

CAPACITY

About 6 pints or up to bottom edge of fill plug hole.

TROUBLE SHOOTING

LUBRICANT LEAKS PAST YOKE OR OUT OF VENT

Overfilled condition or vent could be closed or restricted. Yoke seal could be worn or damaged.

NOISY OPERATION

Incorrect or insufficient lubrication. Incorrect tire pressure. Mismatched or unequal tire sizes and type.

SEVERE LOW SPEED SHUDDER

Low or loss of viscous silicone fluid.

SERVICE (IN VEHICLE)

NOTE — The following procedure outlines replacement of front and rear yokes, yoke seals, rear retainer, rear bearing and speedometer gear.

REMOVAL

1) Raise and support vehicle. Remove skid plate. Remove transfer case drain plug and drain lubricant. Mark propeller shaft and transfer case yoke for installation reference. Disconnect propeller shaft and secure to underside of vehicle. Remove speedometer cable and adapter from rear retainer. Remove and discard speedometer adapter seal.

2) Support engine with support stand (under converter housing if equipped). Remove rear crossmember bolts and using a jack, lower transmission/transfer case assembly to gain access

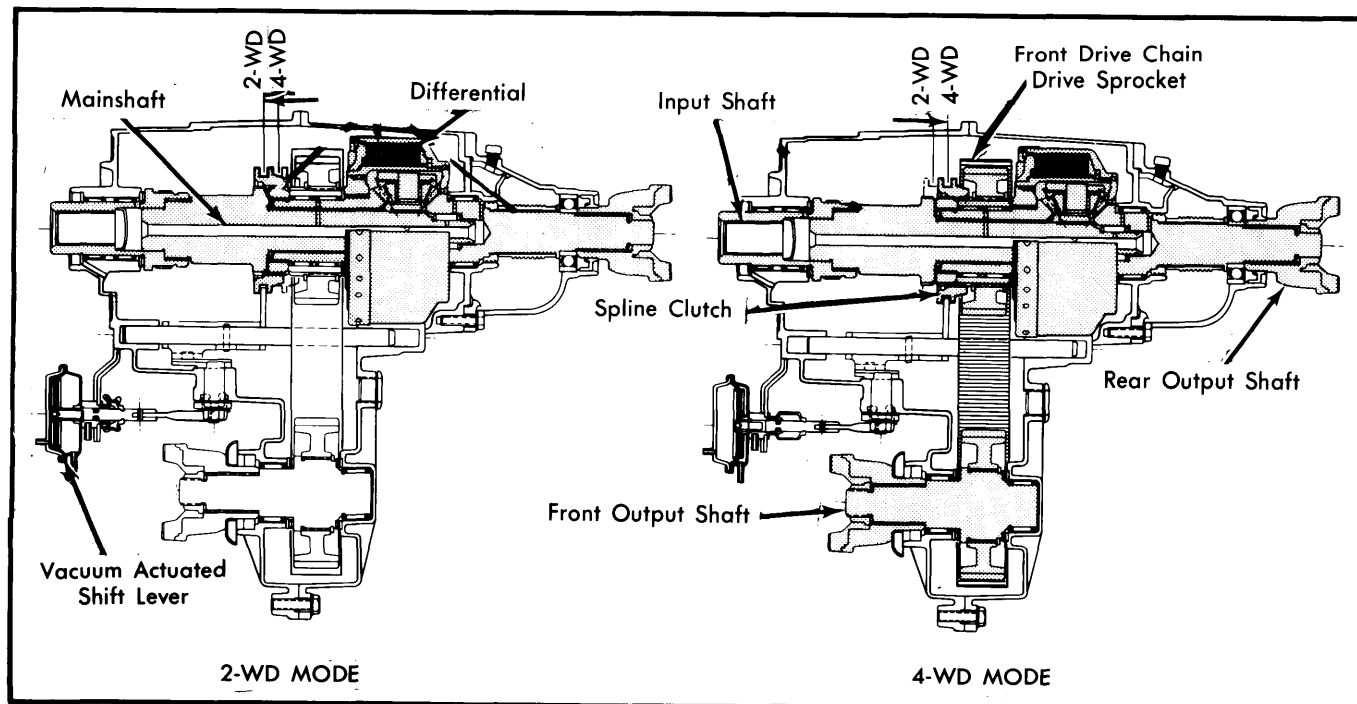

Fig. 1 Sectional View of Eagle Select Drive Transfer Case

AMERICAN MOTORS MODEL 129 (Cont.)

to rear retainer bolts. Mark rear retainer and case for installation reference.

3) Remove rear yoke nut and seal washer. Remove rear yoke using remover (J-8164-01, -02, -03) if required. Remove rear retainer bolts and tap off rear retainer with plastic mallet. DO NOT pry retainer from case. Remove differential shim(s) and speedometer gear from rear output shaft. Remove bearing snap ring (if equipped), bearing and rear yoke seal from retainer.

INSTALLATION

1) Install rear output bearing in rear retainer with shielded side facing case interior. Install bearing snap ring (if equipped), then using installer (J-29162), install yoke seal. Coat rear retainer mating surface with sealant, align marks made during removal and install rear retainer. Tighten retainer bolts. Install yoke, new seal washer and nut. Tighten nut.

2) Install transfer case drain plug and fill transfer case. Raise transmission/transfer case and rear crossmember. Install and tighten crossmember attaching bolts. Remove engine support and jack. Connect propeller shaft after aligning marks made during removal. Install new seal on speedometer adapter. Install adapter and speedometer cable in rear retainer. Install skid plate and lower vehicle.

REMOVAL & INSTALLATION

TRANSFER CASE

Removal (Auto. Trans.) – **1)** Raise and support vehicle. Support engine and transmission with transmission jack or support stand. Disconnect catalytic converter support bracket at adapter housing. Remove skid plate, stiffening brace (if equipped), speedometer cable and adapter. Remove and discard adapter seal.

2) Mark propeller shafts and transfer case yokes for installation reference. Disconnect propeller shafts at yokes and secure to underside of vehicle. Disconnect gearshift and throttle linkage at transmission. Remove rear crossmember and transfer case-to-adapter housing nuts. Lower and remove transfer case from vehicle.

Installation (Auto. Trans.) – To install transfer case, reverse removal procedure and note the following: Always replace speedometer adapter seal.

Removal (Man. Trans.) – **1)** Working inside vehicle, place transmission in neutral and remove gearshift lever bezel-to-floorpan (console) retaining screws. Slide bezel and boot up on gearshift lever and remove lever-to-mounting cover bolts. Remove lever. Remove mounting cover-to-transmission adapter housing bolts and remove cover.

2) Working inside transmission adapter housing, remove transfer case mounting stud nut. Raise and support vehicle. Remove skid plate and stiffening brace (if equipped). Mark position of speedometer adapter, then remove adapter retainer, adapter and speedometer cable. Plug adapter opening to prevent fluid leak.

3) Mark propeller shafts and transfer case yokes for installation reference. Disconnect propeller shafts at yokes and secure to underside of vehicle. Support transfer case with transmission

jack. Remove transfer case mounting stud nuts. Lower and remove transfer case from vehicle.

Installation (Man. Trans.) – To install transfer case, reverse removal procedure and note the following: Always replace speedometer adapter seal.

TRANSFER CASE DISASSEMBLY

1) Drain lubricant from transfer case. Remove front and rear yoke nuts. Remove and discard seal washers. Remove yokes. Mount transfer case on wooden blocks ("V" notch blocks to clear front case mounting studs). Mark rear retainer and rear case for reassembly reference, then remove retainer bolts. Using 2 screwdrivers inserted in retainer and case slots, pry retainer loose.

2) Remove retainer, differential shim(s) and speedometer drive gear. Using 2 screwdrivers inserted in slots at each end of rear case, loosen case halves. Remove rear case.

CAUTION – Do not attempt to wedge case halves apart. Case mating surfaces may be damaged.

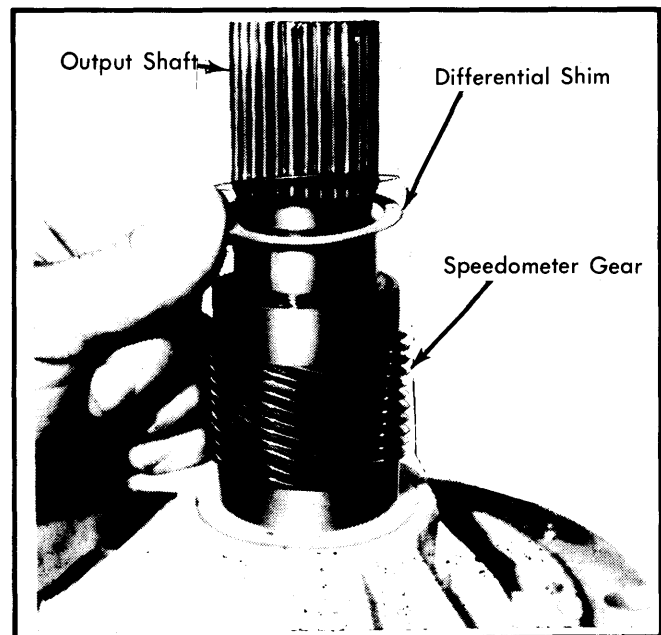

Fig. 2 Speedometer Gear and Differential Shim

3) Remove thrust bearing and races from front output shaft. Note position of bearing and races for reassembly reference. Remove oil pump from rear output shaft. Note position of pump for reassembly reference (recessed side faces case interior). Remove rear output shaft from viscous coupling.

4) Remove 15 mainshaft pilot bearing rollers from shaft or coupling, if rollers dropped off during rear output shaft removal. Remove mainshaft "O" ring from end of shaft. Remove viscous coupling from mainshaft and side gear.

5) Lift front shaft, sprocket and chain upward as an assembly. Tilt front shaft toward mainshaft, slide chain off drive sprocket and remove assembly. Remove front output shaft front thrust bearing assembly from front case or shaft, if bearing and races remained on shaft during removal. Remove drive chain from front output shaft and sprocket.

AMERICAN MOTORS MODEL 129 (Cont.)

6) Remove driven sprocket snap ring from front output shaft. Mark sprocket and shaft for reassembly reference, then remove sprocket. Remove mainshaft, side gear, clutch gear, drive sprocket and spline gear as an assembly. Place assembly aside on clean surface.

7) Remove range fork, rail and clutch sleeve as an assembly. Mark sleeve and fork for reassembly reference, then remove sleeve from fork. Drive roll pin out of fork and rail. Remove rail from fork. Remove mainshaft thrust washer from input gear. Remove input gear, input thrust bearing and race. Remove detent bolt, spring and plunger. Remove range sector shaft retaining nut and washer.

8) Remove range sector. Tap sector shaft with plastic mallet to remove shaft from case bore. Remove range sector shaft "O" ring seal and seal retainer from case bore. Remove rear output bearing and rear yoke seal from rear retainer. Note position of bearing for reassembly reference (bearing is shielded on one side). Remove input gear. Pry front yoke seals out of front case.

CLEANING & INSPECTION

1) Clean all parts in suitable cleaning solvent. Be sure all old lubricant or foreign material is removed from surfaces of every part. Apply compressed air to blow dry parts.

2) Inspect all gear teeth for signs of excessive wear or damage and check all gear splines for burrs, nicks, wear or damage. Remove minor nicks or scratches using an oilstone. Replace any part exhibiting excessive wear or damage.

NOTE — Front output shaft thrust bearing race surfaces are heat treated, causing brown or blue discoloration. Do not replace front output shaft because of this discoloration.

3) Inspect case halves and rear retainer for cracks, porosity, damaged mating surfaces, stripped bolt threads or distortion.

4) Inspect the condition of all bearings. Also check the condition of all bearing bores. Replace any part that exhibits signs of wear or damage.

COMPONENT DISASSEMBLY & REASSEMBLY

CAUTION — All bearings used in transfer case halves must be correctly positioned to avoid blocking bearing oil feed holes. After replacing bearing, check that feed hole is not covered by bearing.

MAINSHAFT

Disassembly — 1) Grasp drive sprocket and lift sprocket, clutch gear and side gear upward and off mainshaft. Remove mainshaft needle bearings (82) and bearing spacers (3) from mainshaft. Note spacer position for reassembly reference. See Fig. 3.

2) Remove spline gear and thrust washer from mainshaft. Remove side gear, clutch gear and clutch gear thrust washer from sprocket carrier and sprocket. Remove clutch gear and thrust washer from side gear.

3) Remove 1 sprocket carrier snap ring and remove drive sprocket from carrier. Mark sprocket and carrier for reassembly reference. Remove 3 bearing spacers and all

sprocket carrier needle bearings from carrier. A total of 120 needle bearings are used.

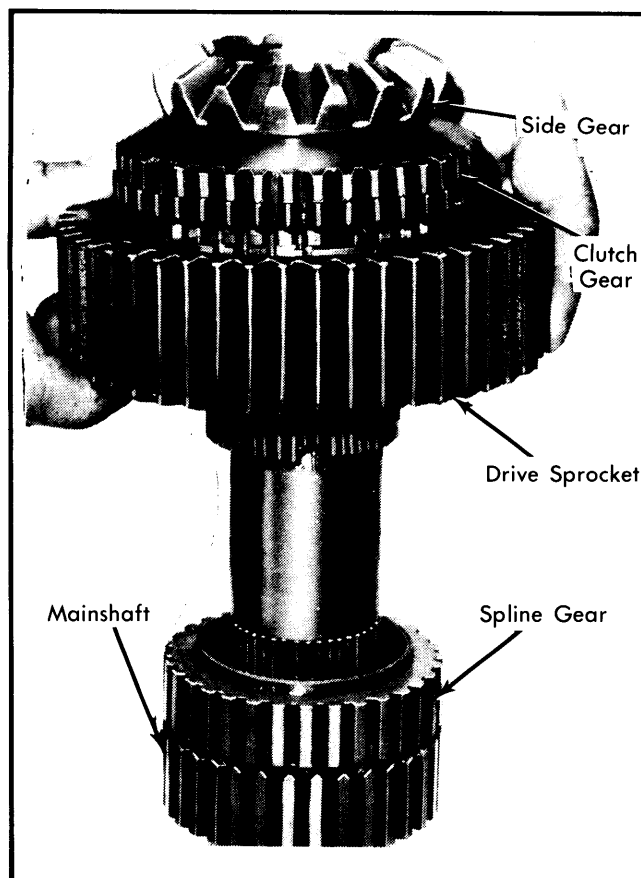

Fig. 3 Removing Drive Sprocket, Clutch Gear, Side Gear and Sprocket Carrier from Mainshaft

NOTE — The sprocket carrier and mainshaft needle bearings are different sizes. Take care to avoid intermixing them.

Reassembly — 1) Install thrust washer, new "O" ring, needle bearings and bearing spacers on mainshaft. Coat shaft bearing surfaces and all needle bearings with petroleum jelly. Install short bearing spacer on shaft and install first 41 needle bearings.

2) Install long bearing spacer, remaining 41 needle bearings and remaining short spacer. Be careful to avoid displacing bearings as spacers are installed. Use additional petroleum jelly to hold bearings in place if necessary. Install spline gear on mainshaft. Take care to avoid displacing bearings while installing spline gear.

3) Install sprocket carrier in drive sprocket and install sprocket carrier snap rings. Be sure to align carrier and sprocket according to reference marks made during disassembly. See Fig. 6.

NOTE — The sprocket carrier teeth are tapered on one side and the drive sprocket has a deep recess on one side. Be sure to assemble these components so the carrier tapered teeth and sprocket recess are on the same side.

Transfer Cases

AMERICAN MOTORS MODEL 129 (Cont.)

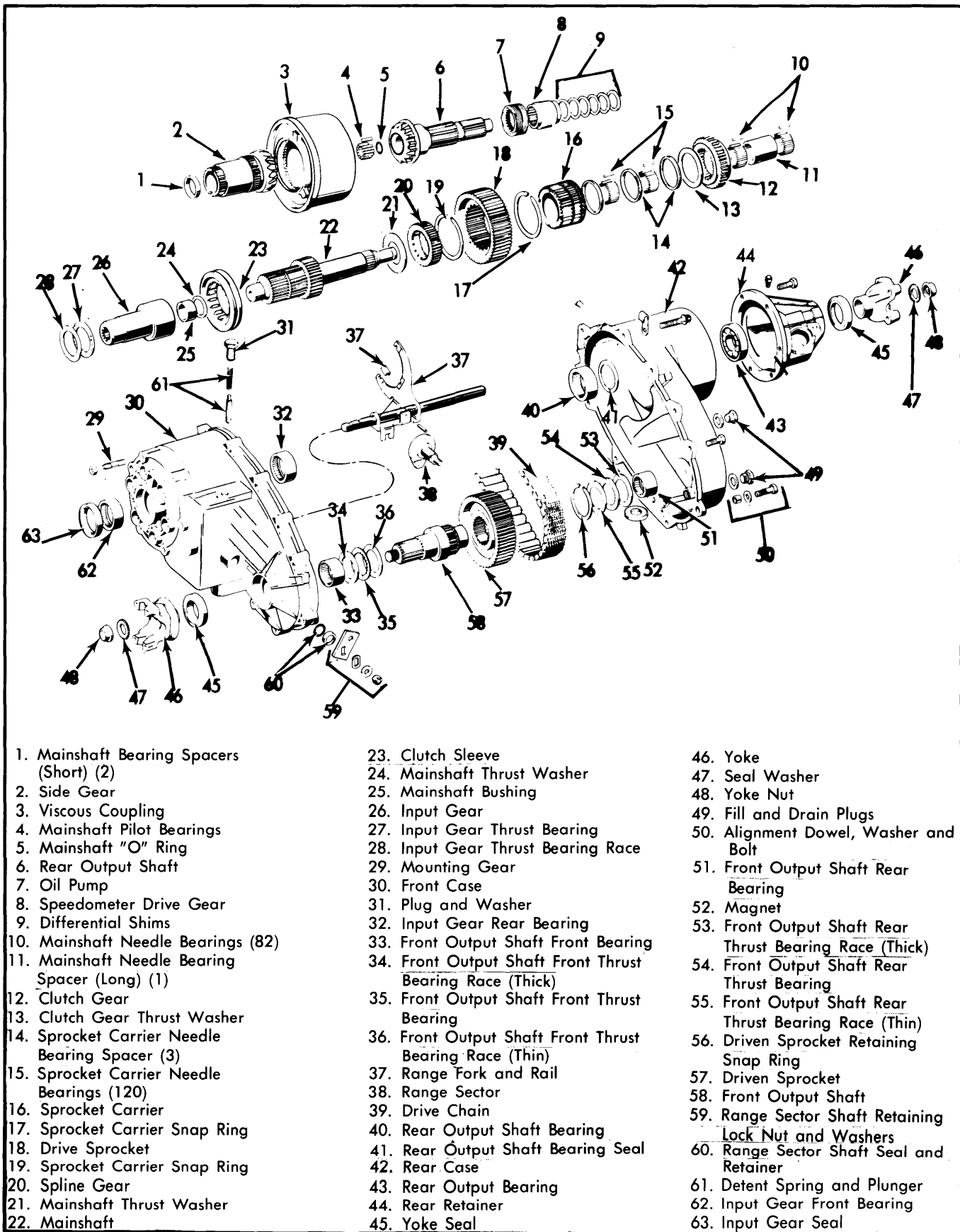

Fig. 4 Exploded View of American Motors Model 129 Transfer Case

AMERICAN MOTORS MODEL 129 (Cont.)

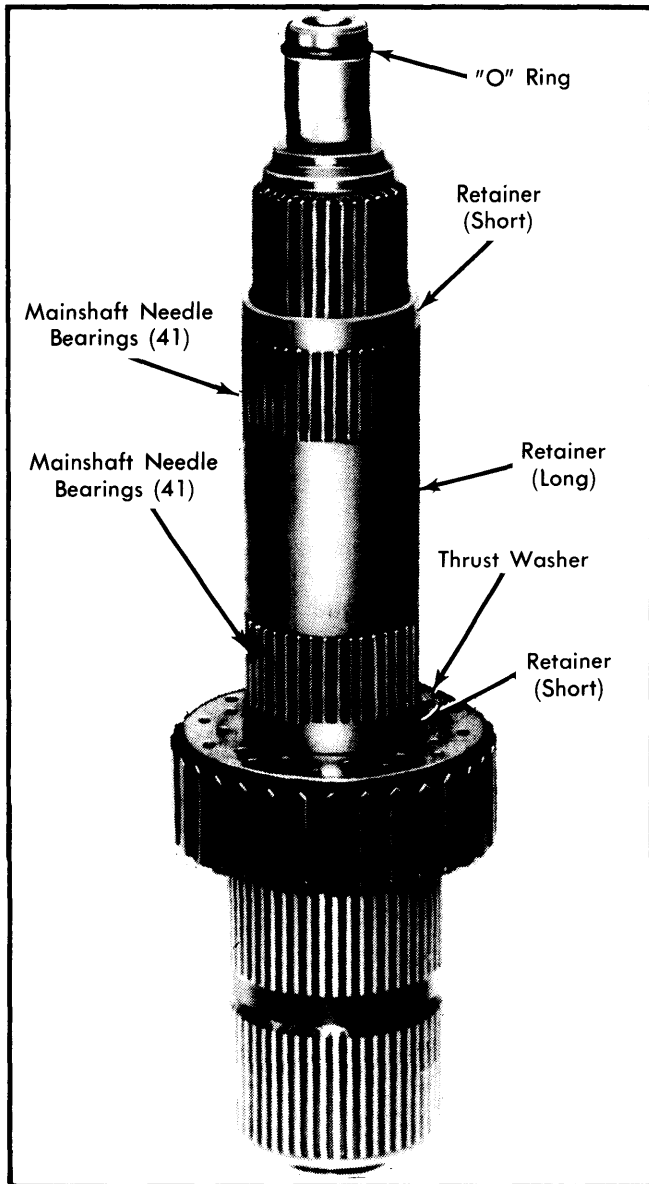

Fig. 5 Installation of Mainshaft Needle Bearing and Spacers

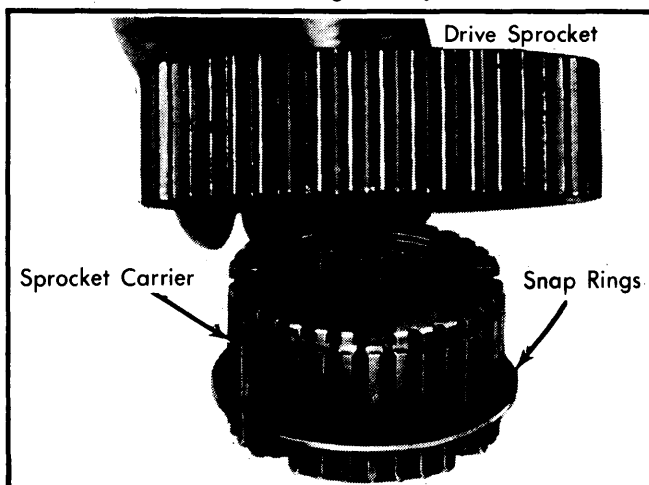

Fig. 6 Installing Drive Sprocket on Sprocket Carrier

4) Install sprocket carrier bearings and spacers. Coat carrier bore and all 120 carrier needle bearings with petroleum jelly. Install center spacer. Install 60 bearings in each end of carrier and install 2 remaining spacers (1 at each end of carrier). Use additional petroleum jelly to hold bearings in place if necessary.

5) Install assembled sprocket carrier and drive sprocket on mainshaft. Do not displace mainshaft bearings during installation. Install clutch gear thrust washer in mainshaft. Position washer on sprocket carrier. See Fig. 7.

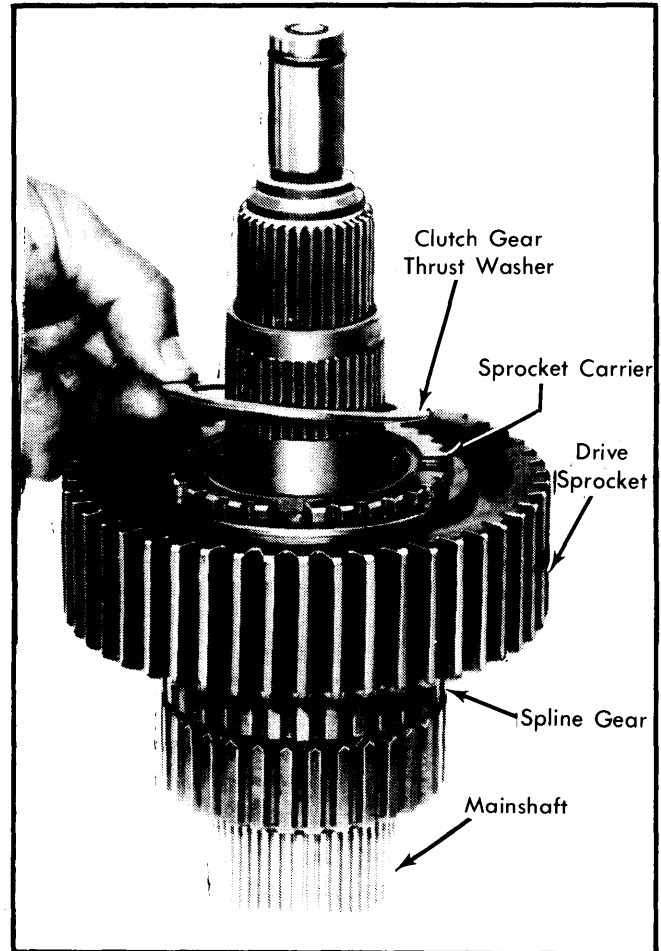

Fig. 7 Installing Clutch Gear Thrust Washer

6) Install clutch gear on side gear. Be sure tapered edge of clutch gear faces side gear teeth. Install assembled side gear and clutch gear on mainshaft. Be sure gear is fully seated in sprocket carrier. Take care to avoid displacing any carrier or mainshaft needle bearings.

NOTE — Clutch gear should be flush with coupling and gear teeth should not be visible.

TRANSFER CASE REASSEMBLY

NOTE — Before reassembling transfer case, verify viscous coupling operation. See Coupling Torque Bias Check in Adjustment section of this article.

1) Install new input gear and front yoke oil seals with installer (J-29162). Install new range sector shaft "O" ring and retainer

Transfer Cases

AMERICAN MOTORS MODEL 129 (Cont.)

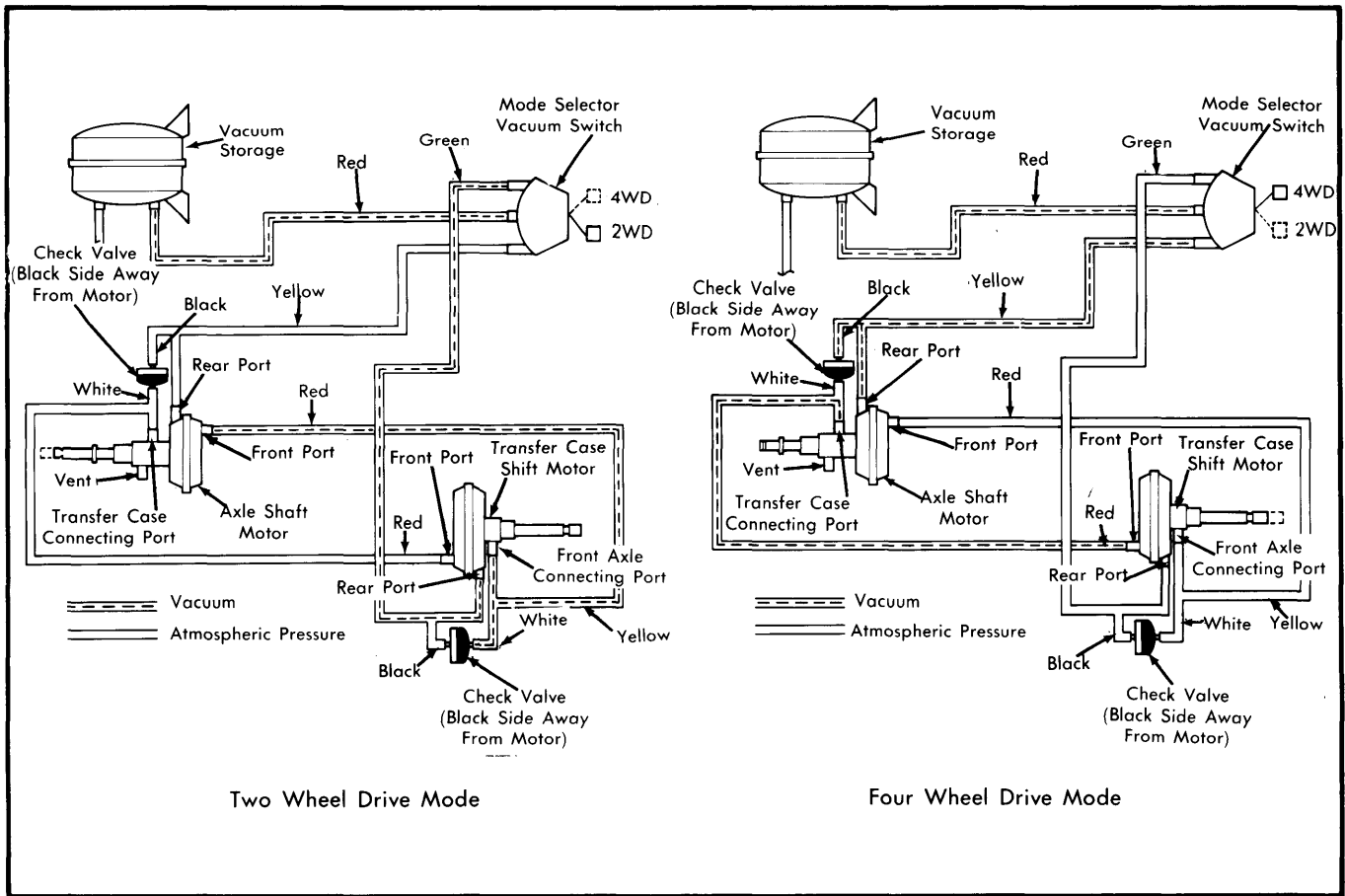

Fig. 8 Select Drive System Vacuum Diagram

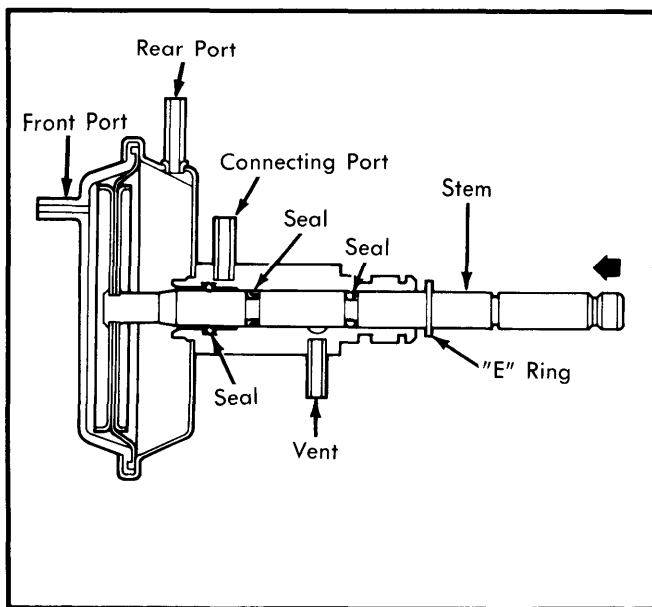

Fig. 9 Typical Select Drive Vacuum Shift Motor. Connecting Port is Supplied With Air When Stem is in Extended Position. Stem is Shown in Retracted Position.

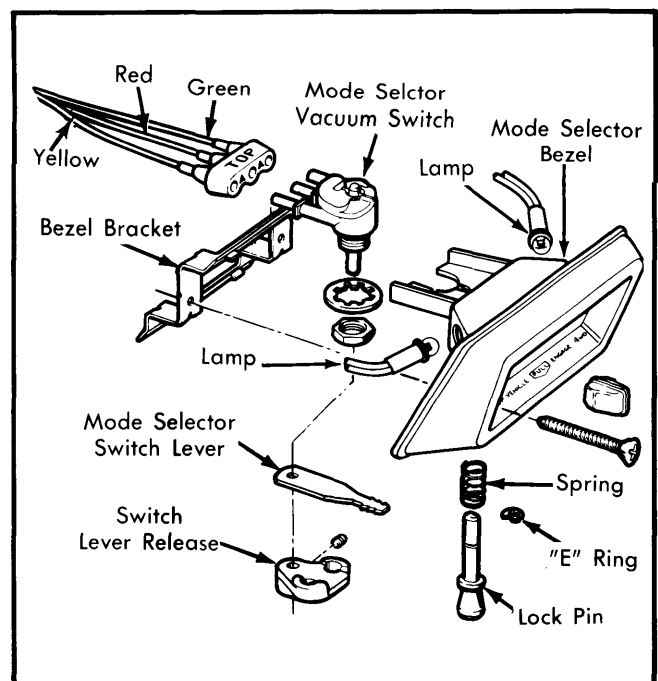

Fig. 10 Exploded View of Select Drive Switch Assembly

AMERICAN MOTORS MODEL 129 (Cont.)

in case shaft bore. Install range sector, washers and lock nut on sector shaft. Tighten lock nut.

2) Install thrust bearing and race on input gear and install gear in front case. Install mainshaft thrust washer in input gear. Assemble range fork, rail and clutch sleeve. Install assembly in case. Be sure rail is fully seated in case bore.

NOTE — The rail bore in the front case must be absolutely dry and free of oil. A small amount of oil in the bore will prevent the rail from seating completely and also prevent rear case installation.

3) Install mainshaft and gear assembly in case. Be sure mainshaft is fully seated in input gear. Install driven sprocket on front output shaft and install sprocket retaining snap ring. Install according to reference marks made during disassembly. Install front output shaft thrust bearing assembly in front case. Install thick race in case, then install bearing and thin race.

4) Install drive chain, front output shaft and driven sprocket. Raise and tilt driven sprocket and chain and install opposite end of chain on drive sprocket. Align front output shaft with shaft bore in front case and install shaft in case. Be sure front shaft thrust bearing assembly is fully seated in case.

5) Install front output shaft rear thrust bearing assembly on front output shaft. Install thin race first, then install bearing and thick race. Install viscous coupling on side gear and clutch gear. Coupling must be fully seated on clutch gear.

6) Coat mainshaft pilot bearing surface and all 15 pilot roller bearings with petroleum jelly and install bearings on shaft. Install rear output shaft on mainshaft and into viscous coupling. Tap shaft with mallet to seat it if necessary. Install oil pump on rear output shaft, install new rear output bearing oil seal in rear case. Apply bead of sealer to mating surface of rear case, install rear case on front case.

7) Install and tighten rear case-to-front case bolts. Flat washers are used on bolts at case ends where alignment dowels are located. Install speedometer drive gear and differential shim(s) on rear output shaft.

8) Align rear retainer on rear case and install retainer. Install retainer bolts and tighten securely; DO NOT tighten to specified torque. Install front and rear output shaft yokes and original yoke nuts. Tighten yoke nuts finger tight.

NOTE — If rear case will not seat properly in the front case, check for the following: Oil in the range fork rail bore, front output shaft rear thrust bearing assembly is not aligned with the rear case, mainshaft is not completely seated, rear case not aligned with oil pump.

ADJUSTMENTS

NOTE — Coupling Torque Bias Check must be performed during reassembly of transfer case.

COUPLING TORQUE BIAS CHECK

1) Install clutch gear on side gear. Install assembled clutch gear and side gear in viscous coupling. Mount assembled viscous coupling and gears in vise which has wood blocks installed. Firmly clamp assembly on side gear.

NOTE — Wood blocks must be placed between vise jaws and side gear to prevent damage to gear.

2) Check engagement of clutch gear in viscous coupling. Clutch gear must be fully engaged in coupling. If necessary reposition wood blocks so they support gear in coupling. Install rear output shaft and install yoke retaining nut. Install torque wrench on yoke nut.

3) Rotate output shaft and measure torque required to rotate shaft in coupling. Rotating torque should be 25 ft. lbs. MINIMUM. If rotating torque is less than specified, replace coupling. If torque is at or above specification, coupling is operating properly.

DIFFERENTIAL END PLAY

1) Mount dial indicator on rear retainer and position indicator stylus so it contacts rear yoke nut.

2) Rotate front output shaft 10 to 12 revolutions and zero dial indicator. Rotate front shaft 1 more revolution and note dial indicator reading. End play should be .002-.010". If end play is incorrect, remove retainer and add or subtract shims as necessary to correct end play.

3) After checking end play, remove front and rear yokes. Discard original yoke nuts, remove rear retainer and apply sealer to retainer mating surfaces. Reinstall retainer and tighten bolts.

4) Install front and rear yokes, new yoke nut and seal. Tighten nut. Install detent ball and spring. Apply sealer to detent bolt and install and tighten bolt. Install drain plug and fill transfer case with lubricant.

TIGHTENING SPECIFICATIONS

Application	Ft. Lbs. (N·m)
Detent Retainer Bolt	20-25 (27-34)
Front and Rear Yoke Nuts	90-130 (122-176)
Rear Case-to-Front Case Bolts	20-25 (27-34)
Rear Retainer Bolts	20-25 (27-34)
Sector Shaft Lock Nut	15-20 (20-27)
Skid Plate Bolts	25-35 (34-47)
Indicator Switch	15-20 (20-27)
Operating Lever Lock Nut	15-20 (20-27)
Drain and Fill Plugs	15-20 (20-27)