

GENERAL MOTORS FRONT WHEEL FINAL DRIVE

Buick Riviera
Cadillac Eldorado & Seville
Oldsmobile Toronado

DESCRIPTION

Front wheel final drive assembly is mounted on and splined directly to the automatic transmission. Unit consists of a pinion drive gear, ring gear and differential case assembly. Torque from final drive unit is transmitted to output shafts, which are connected to drive axles. Output shafts are splined to final drive side gears. Drive axles are flexible assemblies consisting of axle shafts and inner and outer constant velocity joints.

AXLE RATIO & IDENTIFICATION

Axle ratio code and build date are stamped on left side of housing cover mounting surface. Ratio is identified by the 2 letters following the number "4".

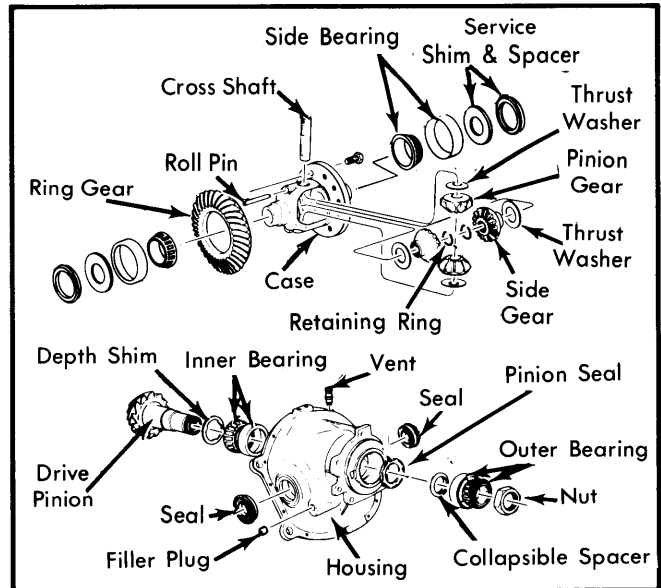

Fig. 2 Exploded View of General Motors Front Wheel Final Drive Assembly

REMOVAL & INSTALLATION

DRIVE AXLES

Removal – 1) Disconnect negative battery cable(s). Raise and support vehicle under frame horns. Remove wheel cover and wheel.

NOTE – If 2-post type hoist is used, raise and support vehicle and lower front post.

2) Remove cotter pin, nut and shield from tie rod pivot. Use suitable puller (J-24319) to remove tie rod end from steering knuckle. Install drive axle boot seal protectors (J-28712) over rubber boots. After inserting a drift through opening in top of brake caliper and into vane of brake rotor to keep axle from turning, remove cotter pin, retainer, nut and washer from drive axle.

3) Remove drive axle-to-output shaft attaching bolts. Remove cotter pin and nut from upper ball joint, pushing drive axle inward to gain access to nut. Pull brake hose clip off of ball joint stud and loosely reinstall nut.

4) Using hammer and brass drift, pound downward on steering knuckle to unseat ball joint stud. It may be necessary to pry upward on upper control arm. Remove nut and separate upper ball joint from steering knuckle. Guide drive axle out of knuckle and remove from vehicle.

CAUTION – Do not stretch or damage brake hose.

Installation – To install, reverse removal procedure.

OUTPUT SHAFTS

NOTE – If both right and left output shafts and/or seals are to be removed or replaced, final drive assembly should be removed from vehicle.

Removal – 1) Remove drive axle. On right output shaft, remove 2 bolts attaching battery cable retainer to support and 2 bolts attaching output shaft support to engine. On both output shafts, remove front nut and bolt from frame brace. Rotate frame brace outward for access.

Axle Ratio Identification

Axle Ratio	Code	Ring Gear Diameter Inches
Buick		
2.93:1	MH	8
3.15:1	ME	8
Cadillac		
2.93:1	MH	8
3.15:1	ME	8
Oldsmobile		
2.41:1	MG	8
2.93:1	MH	8
3.15:1	ME	8

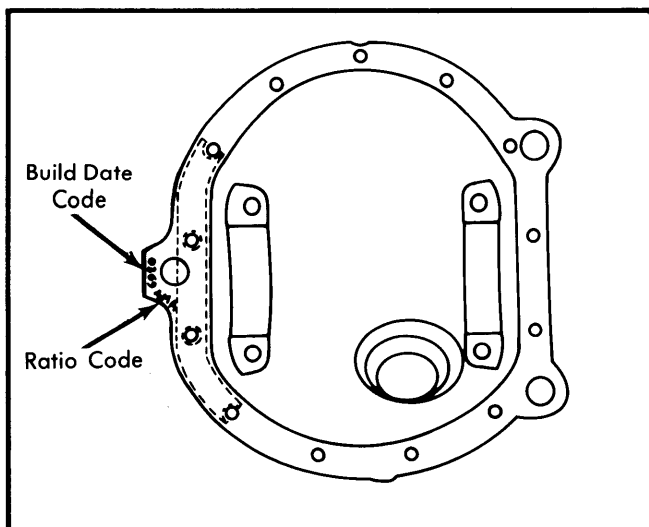

Fig. 1 Axle Ratio Code Location

Front Wheel Final Drive

GENERAL MOTORS FRONT WHEEL FINAL DRIVE (Cont.)

2) Use a hammer and a large brass drift to tap on flanged end of output shaft until it "pops" out of retaining ring. Carefully guide shaft out of vehicle. Use suitable pry bar to remove shaft seal from housing and discard seal.

NOTE — Pry seal at 2 or 3 different locations to avoid cocking seal and damaging housing.

Installation — 1) Install new output shaft seal using suitable installer and handle (J-28518 and J-8092), and apply clean wheel bearing grease between seal lips. Being careful not to damage seal, index output shaft splines with side gear splines and use a soft hammer to tap on center of flanged end of shaft until shaft "snaps" into place.

NOTE — Check spline fit to ensure there will be no drive line clunk. Do not let shaft and support assembly hang in final drive unit or align shaft off center in seal, as seal may be damaged.

2) On right output shaft, align shaft support with holes in engine block, loosely install bolts and washers. Move flanged end of shaft up and down and back and forth to find center location, then fully tighten bolts. Install battery cable retainer to support with 2 bolts. On both output shafts, install drive axle and restore frame brace to original position.

RIGHT OUTPUT SHAFT SUPPORT BEARING

Removal — Remove right output shaft and support assembly from vehicle. Remove 3 self-tapping bolts attaching bearing retainer to support. Slide split halves of suitable bearing remover (J-22912) between flanged end of output shaft and flat area of shaft support and tighten bolts. Press shaft support, bearing, retainer and slinger off of output shaft as an assembly.

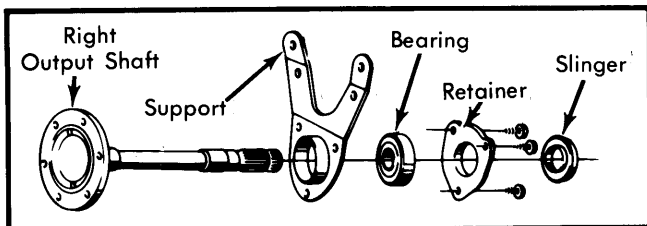

Fig. 3 Exploded View of Right Output Shaft and Support Bearing Assembly

Installation — Pack bearing with wheel bearing grease and install in output shaft support. Install retainer and secure with 3 self-tapping bolts. Place assembled parts and slinger on output shaft. Using an installer tool (J-22535) or a standard 1 1/4" I.D. pipe around shaft as a press tool, press bearing and assembled parts on shaft until seated. Check for free bearing rotation and install output shaft and support on vehicle.

FINAL DRIVE ASSEMBLY

Removal — 1) Disconnect negative battery cable. Raise and support vehicle under frame horns. Remove right and left frame brace front attaching bolts and rotate braces outward to gain access. Loosen final drive cover bolts, drain lubricant; then remove bolts and cover. Install drive axle boot seal protectors (J-28712).

NOTE — If 2-post type hoist is used, raise and support vehicle and lower front post.

2) Remove drive axle-to-output shaft attaching bolts and separate output shaft and drive axle flanges to provide clearance for final drive removal. Remove 2 bolts attaching battery cable retainer to right output shaft support and 2 bolts attaching support to engine. Rotate support downward for removal clearance.

3) Remove final drive-to-transmission bolt attaching rear of final drive shield to transmission and loosen final drive support bracket screw attaching front of shield to final drive. Then, slide shield outward and forward and remove from vehicle.

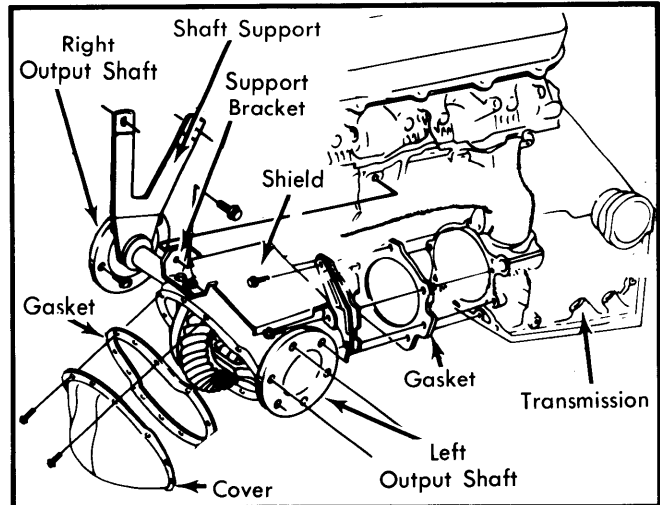

Fig. 4 Attachment of Final Drive Assembly

4) Remove final drive support bracket-to-engine block bolt and 5 remaining final drive-to-transmission bolts. Using suitable puller (J-24319), separate steering linkage intermediate shaft from pitman and idler arms, and push linkage toward front of vehicle. With aid of helper or transmission jack, slide final drive assembly forward, off of splined shaft and remove from vehicle with output shafts attached.

CAUTION — Do not use output shafts as "handles" to maneuver or support final drive assembly. Damage to splines or seals may occur.

Installation — Reverse removal procedure and note the following:

- Position new final drive-to-transmission gasket on final drive. Do not use grease, oil or sealer on gasket.
- Tie arm of right hand output shaft support to the hole in shaft flange closest to twelve o'clock position.
- To ensure proper alignment of right output shaft, loosely install support bolts, move output shaft flange end up and down and back and forth to find central location, and tighten bolts.

OVERHAUL

CONSTANT VELOCITY JOINTS

Disassembly (Outer Joint) — 1) Clamp mid-part of axle shaft in a vise. Use cutters to remove seal retaining clamp. Using a hammer and brass drift, tap lightly and evenly all around seal retainer to remove it from joint assembly and slide seal down shaft.

GENERAL MOTORS FRONT WHEEL FINAL DRIVE (Cont.)

2) Using snap ring pliers to spread retaining ring ears apart, remove joint assembly from shaft. Pull shaft out of joint assembly.

3) Using a hammer and brass drift, gently tap on cage until tilted enough to remove one ball. Continue until all balls are removed. Pivot cage and inner race 90°, align cage windows with lands of outer race and lift out cage and inner race. Pivot inner race 90° in cage, align lands with cage windows and remove inner race from cage.

Reassembly – 1) Place a light coat of grease on ball grooves of inner and outer races. Reverse disassembly procedure to install inner race in cage, cage in outer race and ball bearings in cage.

NOTE – Retaining ring side of inner race must face axle shaft.

2) Slide seal retaining clamp, seal and seal retainer onto shaft. Push joint assembly onto shaft until race retaining ring is fully seated in groove.

3) Coat inside of seal lip with grease and slide lip into seal retainer. Repack joint assembly with approximately half of grease provided with new seal and put remainder in seal. Place suitable support blocks under edge of seal retainer and press joint assembly into retainer. Position seal end in groove on shaft and, using suitable tool (J-22610), secure seal retaining clamp on seal.

Disassembly (Inner Joint) – 1) Clamp mid-part of axle shaft in a vise. Use cutters to remove seal retaining clamp. Using a hammer and brass drift, tap lightly and evenly all around seal retainer to remove it from housing and slide seal down shaft. Pull housing off of shaft.

2) Using suitable snap ring pliers to slide spacer ring back, remove spider assembly from shaft. Slide spider assembly back to expose shaft retaining ring, remove ring and pull spider assembly off shaft.

Reassembly – 1) Slide seal retaining clamp, seal and seal retainer onto shaft. Repack housing with approximately half of grease provided with new seal and put remainder in seal.

2) Slide spacer ring onto shaft about 4". Hold spider assembly with counterbore facing away from shaft and slide assembly onto shaft beyond shaft retaining ring groove on end of shaft. Install shaft retaining ring in groove; then, slide spider assembly back toward end of shaft until it locks in place over retaining ring. Slide spacer ring toward end of shaft until it contacts spider and seat it in groove.

NOTE – Raised ring on spider assembly must face axle shaft.

3) Slide housing over spider assembly. Coat inside of seal lip with grease and slide lip into seal retainer. Repack joint assembly with approximately half of grease provided with new seal and put remainder in seal. Place suitable support blocks under edge of seal retainer and press housing into retainer. Position seal end in groove on shaft and using band installer (J-226610), secure retaining clamp on seal.

FINAL DRIVE DISASSEMBLY

NOTE – Before disassembling unit, check and record ring gear-to-pinion backlash, total drive pinion preload torque and ring gear runout.

1) Remove final drive assembly from vehicle. Mount assembly on suitable holding fixture (J-23320-A).

2) Mark bearing caps for reassembly reference; then, remove cap bolts and bearing caps. Using suitable pry bar, remove differential case by prying against ring gear bolt. Mark shims for reassembly reference.

3) If differential side bearings are to be replaced, remove using a puller or press. Using a punch and hammer, drive pinion cross shaft roll pin out of differential case and remove pinion cross shaft. Remove pinion gears, side gears and washers by rotating gears to opening in case and removing. Mark pinion gears, side gears and washers for installation in original positions.

4) Remove all but 2 ring gear-to-case bolts, leaving them loosely installed 180° apart. Remove ring gear from case by alternately tapping on these 2 bolts.

5) Check pinion bearing preload using spline adapter (J-28513) and $\frac{3}{8}$ " drive torque wrench. Record reading. To remove pinion nut, install nut holding wrench (J-28514) to hold nut while turning pinion CLOCKWISE with spline adapter (J-28513). Remove pinion by threading original nut partially onto pinion to protect threads and tap with hammer to free pinion. See Fig. 6.

6) Remove nut, outer bearing, collapsible spacer and pinion. Using hammer and drift, drive pinion seal out of housing toward inside of housing. Drive outer bearing race out from inside of housing.

NOTE – Ensure drain hole is not plugged when replacing pinion oil seal.

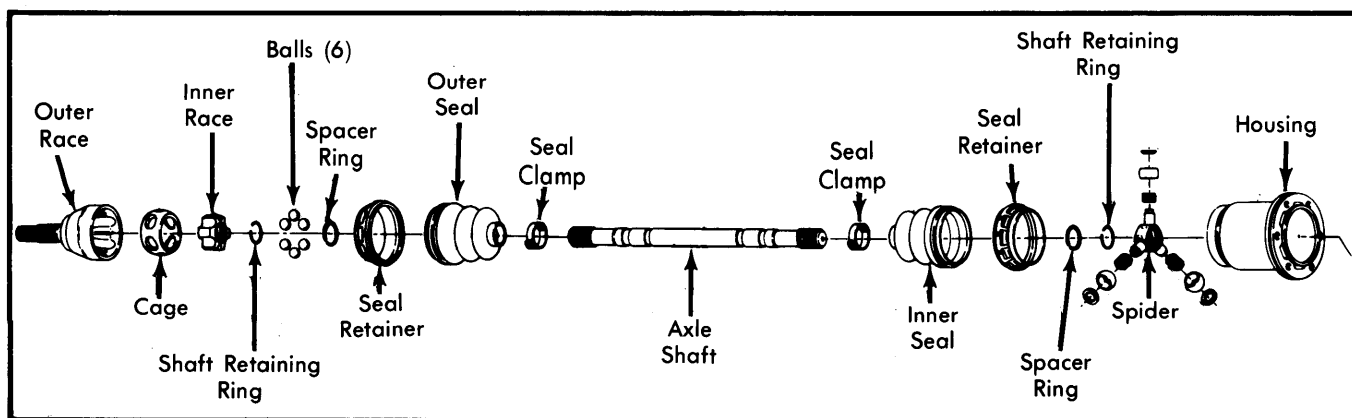

Fig. 5 Exploded View of Front Drive Axle Assembly

GENERAL MOTORS FRONT WHEEL FINAL DRIVE (Cont.)

7) Remove inner bearing race by installing remover (J-28512) between housing bore and race. Tap race out with slide hammer. Using bearing remover (J-9746-02), press pinion shaft out of inner bearing and note thickness of pinion depth shim.

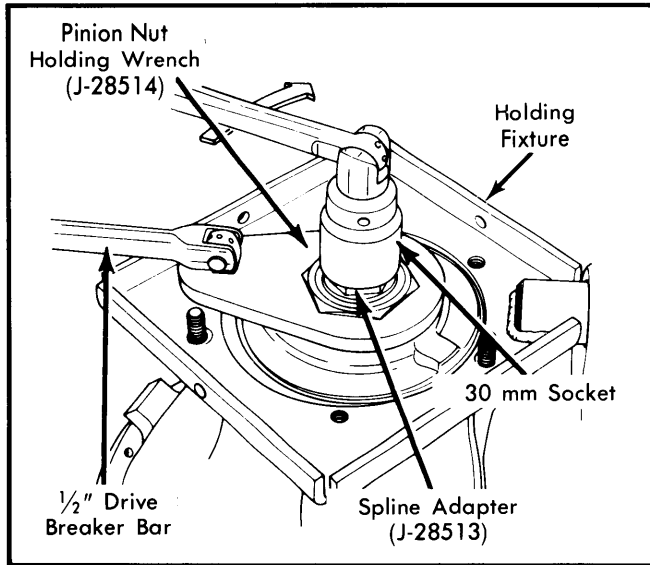

Fig. 6 Removing or Installing Pinion Nut

CLEANING & INSPECTION

Wash all parts in solvent or mineral spirits; then, dry thoroughly using dry, compressed air. Using a clean cloth, wipe inside of housing clean. Inspect all parts for chips, nicks, and excessive wear. Replace parts as necessary.

REASSEMBLY

NOTE — Use pinion gauge set J-21777-75 to obtain proper pinion depth setting.

Pinion Depth Setting — 1) If original ring gear, pinion and inner pinion bearing are to be reinstalled, the original shim thickness may be used. If installing new components, perform the following procedure.

CAUTION — Inner pinion bearing race is used as stop gauge for pinion oil seal installing tool. Inner race **MUST** be installed before pinion seal. If race is not correctly seated, seal may leak.

2) Clean housing assembly and all gauge parts to ensure accurate measurements. If removed, install pinion bearing races; then, install lubricated pinion bearings in their races. Position inner bearing pilot (J-21777-8) on short threaded end of preload stud (J-21777-43). Thread gauge plate (J-21777-77) onto stud and tighten against pilot. Insert stud through inner and outer bearings, install outer bearing pilot (J-21777-78) and nut. Rotate bearings to ensure proper seating. Tighten nut until 20 INCH Lbs. are required to rotate bearings.

3) Mount side bearing gauging discs (J-21777-45) on ends of arbor (J-21777-1) with smaller steps out. Place assembly in housing, making sure discs are properly seated. Install bearing caps and bolts finger tight to prevent movement. Position dial indicator on mounting post of arbor with contact button resting on top of surface plunger. Preload dial indicator 1/2 revolution and tighten in this position.

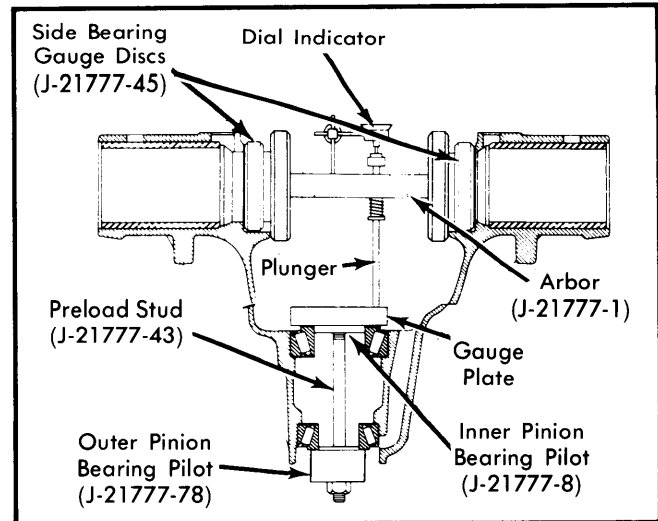

Fig. 7 Pinion Depth Gauge Set

4) Rotate gauge plate until plunger rests squarely on flat surface of plate. Rock plunger rod slowly back and forth across plate until indicator reads greatest deflection; then, set indicator to zero. Repeat rocking action several times to verify setting. Once zero reading is obtained, swing plunger until it is removed from gauge plate. Dial indicator will now read required shim thickness for a "nominal pinion". Record this reading.

5) Check inner face of drive pinion for a stamped code number. If pinion is stamped with a plus number (for example, "+2"), add that many thousandths to dial indicator reading to determine shim thickness. If pinion is stamped with a minus number (for example, "-5"), subtract that many thousandths to determine shim thickness. If no code is present, use dial indicator reading as shim thickness.

6) Remove bearing caps and gauging tools from housing. Place selected shim pack on pinion and install lubricated bearing onto pinion shaft using a suitable press.

Pinion Installation & Preload Adjustment — 1) Install pinion seal in housing and lubricate with transmission fluid. Lubricate inner bearing with differential lube, install suitable seal protector on pinion, and position pinion in housing. Lubricate outer pinion bearing with transmission fluid and install new collapsible spacer, outer pinion bearing and nut (finger tight) on pinion shaft.

NOTE — Nut can only be partially installed due to nylon coating on threads.

2) Using spline adapter (J-28513) and holding wrench (J-28514), tighten pinion nut until end play begins to be taken up. (Turning spline adapter COUNTERCLOCKWISE tightens nut). See Fig. 6. When no further end play is felt, use spline adapter and 3/8" drive torque wrench to check preload. Continue tightening nut and checking preload until specified preload is obtained.

CAUTION — Do not back off nut to lessen preload. If preload is exceeded, a new collapsible spacer must be installed and nut retightened to obtain proper preload.

Case Reassembly — Place ring gear onto case, install new bolts and tighten to pull ring gear into position on case. Place side gear thrust washers over side gear hubs. Then, install

GENERAL MOTORS FRONT WHEEL FINAL DRIVE (Cont.)

assemblies into case in original positions. Install pinions and thrust washers into case; then, install pinion shaft and roll pin. If removed, install side bearings onto case.

NOTE — Ring gear bolts with serrated heads (bottom side) do not require use of Loctite. All other ring gear bolts require use of Loctite.

Side Bearing Preload — 1) This adjustment is to be made before pinion is installed. If pinion is installed, remove ring gear from case. Measure thickness of original side bearing preload shims. Select a service spacer (.170") and service shims with a total thickness slightly less than the original shims. Install differential case in housing. Install service spacer between each bearing race and housing with chamfered edges of spacer against housing.

2) With right (ring gear side) bearing race and spacer against housing, install both right and left service shims (previously selected) between left (opposite ring gear) bearing race and service spacer. Insert progressively larger feeler gauges until a noticeable drag is felt.

NOTE — To obtain correct reading, push feeler gauge downward until end of gauge contacts housing bore.

3) Remove differential case and install ring gear (if removed). Remove service shims from left side. Select 2 shims of equal thickness with a total thickness equal to service shim thickness plus feeler gauge reading. Install case in housing. Insert selected shims between bearing race and service spacer on both right and left sides. Adjust differential backlash. Then, preload bearings by replacing right and left service shims with shims .004" (total .008") thicker on Toronado and .003" (total .006") thicker on all other models.

NOTE — Do not attempt to reinstall original production shims as they will break when tapped into place. Previously installed SERVICE shims and spacers may be re-used.

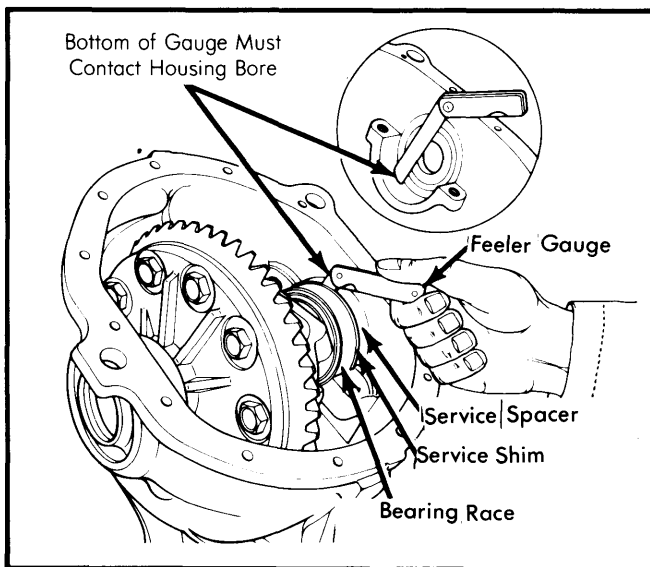

Fig. 8 Determining Side Bearing Shim Requirements

Ring Gear & Pinion Backlash — 1) Mount dial indicator on axle housing and check backlash at 4 locations around ring gear. Variation should not exceed .002". Backlash for new gears should be as specified. If original gears have been reinstalled, backlash should be reset to reading recorded before disassembly.

2) To adjust backlash, increase thickness of 1 shim and decrease thickness of opposite shim by an equal amount until correct reading is obtained. Install bearing caps, recheck backlash and readjust if necessary.

TIGHTENING SPECIFICATIONS

Application	Ft. Lbs. (N·m)
Drive Axle-to-Output Shaft Bolts	61 (82)
Drive Axle Nut	176 (238)
Output Shaft Support-to-Engine Bolts	50 (68)
Final Drive Support Bracket-to-Engine	
All Except 4.1L V8	70 (95)
4.1L V8	35 (47)
Final Drive Support Bracket-to-Housing	33 (45)
Final Drive-to-Transmission Bolts	30 (41)
Upper Ball Joint Stud Nut	
Toronado	90 (125)
All Others	61 (83)
Lower Ball Joint Stud Nut	
Toronado	50 (68)
All Others	85 (115)
Tie Rod-to-Steering Knuckle Nut	
Toronado	30 (41)
Riviera	44 (60)
All Others	40 (54)
Ring Gear-to-Case Bolts	
Eldorado & Seville	96 (130)
Riviera	90 (125)
Toronado	80 (110)
Bearing Cap Bolts	41 (56)
Housing Cover Bolts	7 (101)

SPECIFICATIONS

Application	Clearance or Torque
Side Bearing Preload	
Toronado	① Slip Fit Plus .008"
All Others	② Slip Fit Plus .006"
Pinion Bearing Preload	
Used Bearings	③
New Bearings	18-24 INCH lbs.
Ring Gear-to-Pinion Backlash	
Used Gears	④
New Gears	
Toronado	.005-.007"
All Others	.005-.009"
Capacity	3.2 Pts.

- ① — Add .004" to each side after backlash is set.
- ② — Add .003" to each side after backlash is set.
- ③ — Pre-disassembly reading plus 5 INCH lbs.
- ④ — Restore to pre-disassembly reading.