

# General Motors V8 Engines

## 4.3 & 5.0 LITER V8

### IDENTIFICATION CODING

#### ENGINE IDENTIFICATION

Engine may be identified from the Vehicle Identification Number (VIN) stamped on a metal tab located on top of instrument panel at lower left of windshield. VIN number code also appears as part of a production or unit number stamped on a pad on left front of engine, below cylinder head on all Buick models. On Oldsmobile and Pontiac models, a code tape is found on front of left side valve cover. The VIN number contains 17 digits. The 8th digit identifies the engine and the 10th digit establishes the model year.

Engine Code	
Engine	Code
4.3L (260") 2-Bbl. ....	8
5.0L (307") 4-Bbl. ....	Y

#### SPECIAL ENGINE MARKS

Information identifying oversize and undersize components are stamped in the following locations:

**O** — On side of lifter bore indicates .010" (.25 mm) oversize lifters.

**X** — Stamped on No. 6 counterweight indicates .010" (.25 mm) undersize crankshaft rod journals.

**3, 5, 10 or 13** — Stamped on inboard side of cylinder head above intake manifold indicates oversize valve guides are used in .003", .005", .010" or .013" (.08, .13, .25 and .33 mm) oversize. Standard valve guides have no stamping.

### CYLINDER HEAD & MANIFOLDS

#### INTAKE MANIFOLD

**Removal** — Drain radiator and remove air cleaner assembly. Disconnect all coolant hoses to manifold, throttle cable, fuel and vacuum lines. Remove temperature gauge wires and disconnect or remove alternator and A/C compressor brackets, as necessary. Remove bolts and lift off intake manifold assembly from engine with carburetor attached.

**Installation** — Clean all gasket surfaces. Coat both sides of new intake manifold gasket with sealer and install gasket on head. Install end seals, being sure that end of seals are positioned under edges of heads. Install manifold. Dip bolts in engine oil and install. Tighten bolts first to 15 ft. lbs. (20 N·m), then tighten to specifications. See Fig. 1. Reverse removal procedure to complete installation.

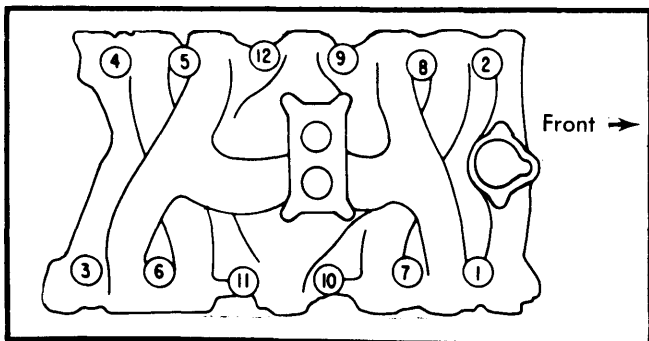

Fig. 1 Intake Manifold Tightening Sequence

#### EXHAUST MANIFOLD

**Removal (Left Side)** — 1) On all models except Cutlass, remove air cleaner, hot air shroud and lower alternator bracket. On all models, raise vehicle on hoist. Disconnect or remove exhaust crossover pipe. On Toronado models, remove exhaust pipe.

2) On all models, lower vehicle. On Cutlass model, disconnect intermediate steering column shaft and remove hot air shroud. On all models, remove exhaust manifold from above.

**Removal (Right Side)** — Raise vehicle on hoist. Disconnect or remove exhaust crossover pipe. Disconnect exhaust pipe. On all models except Cutlass, remove right front tire and wheel assembly. On all models, remove exhaust manifold from under vehicle.

**Installation** — Reverse removal procedure and tighten bolts to specifications to complete installation.

#### CYLINDER HEAD

**Removal** — 1) Drain cooling system. Block may be sufficiently drained by raising rear wheels 24". Remove intake and exhaust manifolds. Remove valve cover, rocker arm bolts, pivots, rocker arms and push rods.

**NOTE** — Keep components separate for reinstallation in original location.

2) Loosen or remove any accessory brackets which interfere. Disconnect ground strap. Remove bolts and cylinder head.

**Installation** — Clean all gasket surfaces. Gaskets are composition type and must be installed WITHOUT sealer. The gaskets for the 4.3L (260") engine are installed with the contrasting color stripe facing up. The 5.0L (307") engine does not have a color stripe on gasket. Install cylinder heads. Dip head bolts in engine oil and install. Tighten head bolts in 2 steps in sequence shown. See Fig. 2.

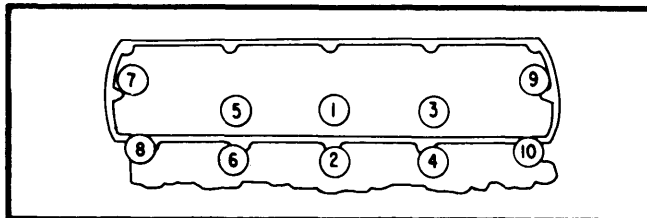

Fig. 2 Cylinder Head Tightening Sequence

### VALVES

#### VALVE ARRANGEMENT

I-E-I-E-E-I-E-I (both banks, front to rear).

#### VALVE GUIDE SERVICING

Guides are integral with cylinder head. If stem-to-guide clearance is excessive, replace valve. Some valves with oversize stems are used in production, and can be identified by marks on inboard side of cylinder head on machined surface just above intake manifold. Valve guide reamers are available in .003", .005" and .013" (.08, .13 and .33 mm) oversize. When reconditioning, always use next oversize reamer and replacement valve. Service valves are available in standard, .003", .005", .010" and .013" (.08, .13, .25 and .33 mm) oversizes.

## 4.3 & 5.0 LITER V8 (Cont.)

### VALVE STEM OIL SEALS

Cup type seals are used on all valves. Using suitable tool (BT-6804), install seals with cupped side down toward cylinder head. Position seals down as far as possible on valve stems. Seals will correctly position themselves when engine is started.

Valve Seal Identification		
Stem Diameters	Intake Seal Color	Exhaust Seal Color
Standard to .005" (.13 mm)		
Oversize .....	Gray .....	Ivory
.010" to .013" (.25 to .33 mm)		
Oversize .....	Orange .....	Blue

### VALVE SPRINGS

**Removal** — Remove rocker arm cover, spark plug and rocker arm assemblies on cylinder(s) to be serviced. Install air line adapter (BT-72-1B) to spark plug port and apply air to hold valves in place. Using a valve spring compressor, compressor valve spring and remove valve keys, rotators and springs. If spring is off square more than 1/16" (1.59 mm), replace spring.

**Installation** — Reverse removal procedure and ensure that valve keys are securely locked in groove of valve stem.

### VALVE STEM INSTALLED HEIGHT

1) To measure valve stem height, place gauge tool (BT-6428 or equivalent) on cylinder head and measure clearance between gauge surface and end of valve stem. Minimum clearance should be .015" (.38 mm). If clearance is less than specified, remove valve and grind tip of stem to a 90° end.

2) Install valve assemblies in cylinder head. Tap each valve stem end with hammer to seat valves, rotators and keepers.

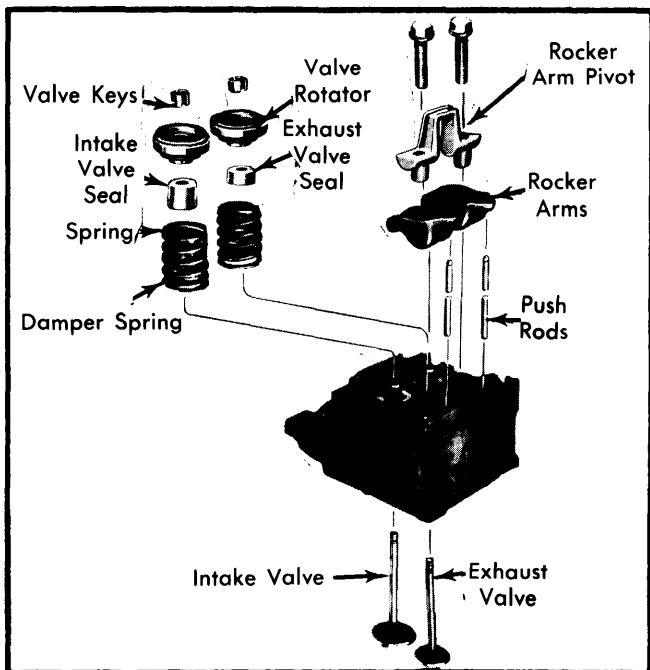

**Fig. 3** Rocker Arm & Valve Assemblies

Place gauge tool (BT-6428 or equivalent) on cylinder head and measure clearance between gauge surface and end of valve stem again.

3) If within specifications, measure clearance between gauge surface and valve rotators. Minimum clearance should be .030" (.76 mm). If clearance is less than specified, valve is too short and must be replaced.

### ROCKER ARM ASSEMBLY

Friction surfaces of rocker arms and pivots must be coated with a suitable lubricant upon reassembly and installed in original locations. Tighten hardened flanged bolts alternately to prevent breaking pivots.

### HYDRAULIC VALVE LIFTER ASSEMBLY

1) Using suitable tool (BT-6407), remove valve lifter assemblies. Keep in sequence for installation in original location. Some engines have both standard and .010" (.25 mm) oversize lifters. Oversize is etched "O" on side of lifter and cylinder block. Inspect all components for nicks, burrs or scoring of parts.

2) If either body or plunger is defective, replace with new lifter assembly. Check lifter foot for wear by placing straightedge across foot. Replace any lifter showing concave surface wear.

**Leakdown Testing** — Lifter must be assembled while submerged in test fluid. Proceed as follows:

1) Install suitable adapter tool (BT-105-2) in reservoir of suitable leakdown tester (BT-60) and fill reservoir with test fluid (BT-59) to 1/2" below top of reservoir. Assemble ball check, ball check spring and retainer in plunger with flange pressed tight against bottom of recess in plunger. See Fig. 4.

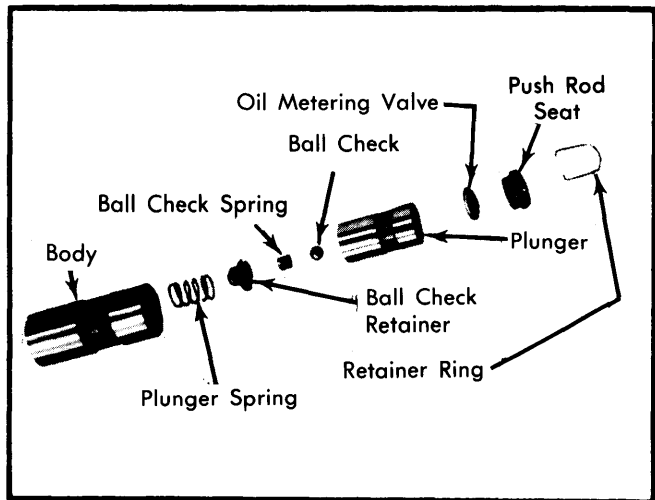

**Fig. 4** Hydraulic Valve Lifter Assembly

2) Install plunger spring over retainer. Hold plunger with the spring up and insert into lifter body (to prevent cocking spring). Place assembly in tester cup and position push rod seat into plunger. Position 1/4" steel test ball on push rod seat and lower tester ram until it contacts steel ball. Allow ram to move downward by its own weight until air bubbles disappear. Repeat several times until all air is expelled from lifter.

**CAUTION** — Do not attempt to expel the air from lifters by pumping the ram.

## 4.3 & 5.0 LITER V8 (Cont.)

3) After air is removed, allow ram to bleed down lifter to expose ring groove. Install retaining ring. Adjust ram screw so it contacts steel ball in push rod seat when pointer is at start line. Raise arm and start test by resting ram on steel ball.

4) Rotate reservoir one revolution every two seconds, and time indicator from start line to stop line. Allowable leakdown time is 6 seconds for used lifters and 12-87 seconds for new lifters.

**NOTE** — If lifter is within specifications, place in service without removing test fluid.

### VALVE TIMING

1) Remove distributor cap, right valve cover, No. 4 cylinder intake and exhaust rocker arms and pivot. Remove wire from "BAT" terminal at distributor. Turn ignition switch on and crank engine until rotor is in line with No. 4 spark plug wire position (No. 4 piston at top of cylinder).

2) Measure from pivot boss on head surface to top of No. 4 intake push rod and record measurement. Crank engine until rotor approaches No. 1 spark plug wire position. Continue to turn engine until timing mark on crankshaft pulley is at TDC. Measure from pivot boss surface to top of No. 4 intake push rod. Measurement should increase over first recorded measurement. If measurement increase is not within  $\frac{1}{32}$ " (.79 mm) of first measurement, camshaft is advanced or retarded.

### PISTONS, PINS & RINGS

#### OIL PAN

See *Oil Pan Removal at end of ENGINE Section.*

#### PISTON & ROD ASSEMBLY

**Removal** — 1) With oil pan, oil pump and cylinder head removed, use a suitable ridge reamer to remove any ridge or deposits on upper end of cylinder bore.

**NOTE** — Piston must be at bottom of stroke and covered with cloth to collect cuttings.

2) Inspect connecting rods and caps for cylinder identification and mark as necessary. Remove rod cap and install a short piece of  $\frac{3}{8}$ " hose over connecting rod studs. Push piston and rod assembly out top of cylinder block. Remove other piston and rod assemblies in same manner.

**Installation** — Lightly coat pistons, rings and cylinder walls with engine oil. Install ring compressor on piston and install piston and rod assembly in its respective cylinder bore with notch on piston head facing front of engine. Guide connecting rod onto crankshaft journal while tapping piston head with hammer handle to seat connecting rod against crankshaft. Install mating rod cap and tighten rod cap nuts.

#### FITTING PISTONS

When measuring piston for side clearance or taper, measurement must be made on skirt 90° from piston pin hole (with piston pin removed). The largest reading must be taken at bottom of skirt. Maximum allowable clearance is .0003-.0017" (.007-.043 mm). Measure cylinder bore with inside micrometer or cylinder bore gauge 90° to crankshaft. Maximum cylinder out-of-round is .001" (.025 mm).

Maximum cylinder taper is .001" (.025 mm). Pistons are available in standard, standard high limit and .010" (.025 mm) oversize.

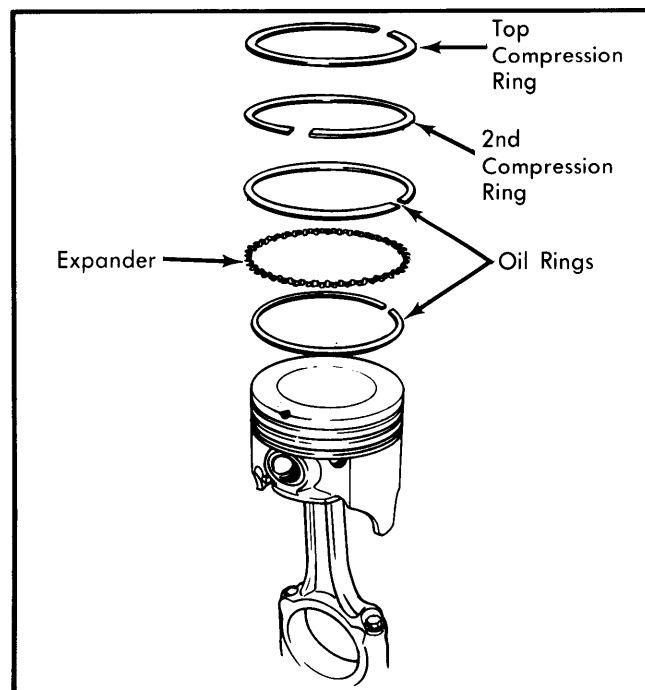

Fig. 5 Piston Ring Positioning

#### PISTON PINS

Using components from tool set J-24086 or BT-7612, remove and install piston pin. Be sure that piston and rod pin holes are clean and free of oil when fitting piston pin. Press pin in until it contacts tool stop. See Fig. 6.

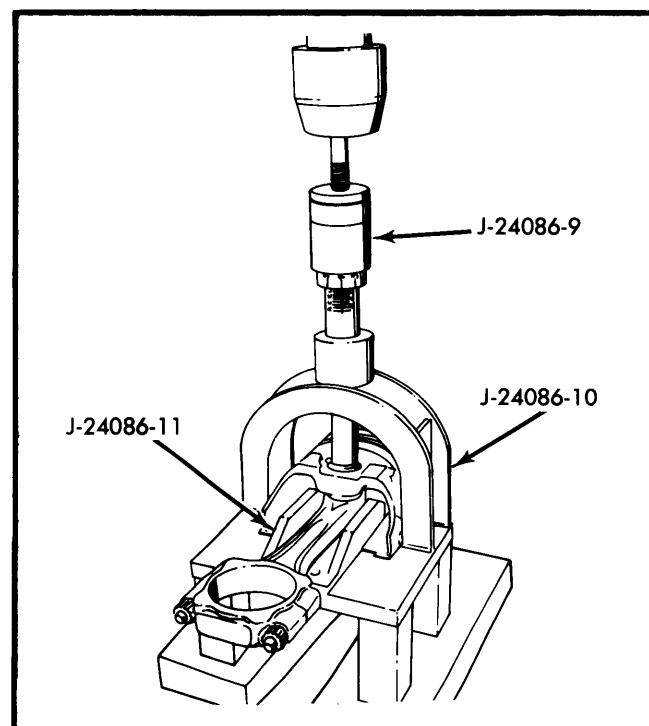

Fig. 6 Piston Pin Removal & Installation

## 4.3 & 5.0 LITER V8 (Cont.)

### CRANKSHAFT & ROD BEARINGS

#### MAIN & CONNECTING ROD BEARINGS

**NOTE** — Following procedures are performed with oil pan and oil pump removed.

**Connecting Rod Bearings** — After ensuring rod caps are marked for cylinder identification, remove rod caps. Use Plastigage method to check for proper bearing clearances. If not within specifications, new bearings must be installed. Bearings may be installed without removing piston and rod from engine. Check connecting rod journals for .0015" (.038 mm) maximum out-of-round. Coat bearing surfaces with oil, install rod cap and tighten nuts. Measure rod side clearance by spreading rods with screwdriver and inserting feeler gauge. Clearance should be .006-.020" (.15-.51 mm).

**NOTE** — Tang on bearing half must fit with notch on rod cap and connecting rod.

**Main Bearings** — 1) Support crankshaft at both front and rear and ensure that all bearing caps, other than one being checked, are tight. Starting with rear main bearing cap and working forward, remove one cap at a time and check bearing clearances using Plastigage method. Maximum permissible journal out-of-round is .0015" (.038 mm).

**NOTE** — When replacing bearings, loosen main bearing caps. Never use shims. Always install bearing halves in pairs. Never use an old bearing half with a new one.

2) To replace upper main bearing half, insert a flattened cotter pin or roll pin in oil passage hole in crankshaft and rotate crankshaft in direction opposite to cranking rotation. Place new upper bearing half on crankshaft journal with locating tang in correct position. Rotate shaft to turn bearing into place using tool used in removal. Tighten all main bearing cap bolts and rotate crankshaft. Be sure there is no excessive drag. Measure crankshaft end play. End play should be .0035-.0135" (.089-.343 mm) using dial indicator.

#### REAR MAIN BEARING OIL SEAL

**Repair & Installation** — 1) Drain crankcase, remove oil pan and rear bearing cap. Using packing tool (BT-6433), gently drive old seal into groove until it is packed tight. This may vary from 1/4" to 3/4" (6 to 20 mm) depending on amount of pack required. Repeat on other end of seal in block.

2) Measure amount seal was driven up on one side, add 1/16" (1.6 mm), then cut this length from old seal removed from main bearing cap. Place a drop of sealer on each end of seal and cap. Using 2 small screwdrivers, work both pieces (1 each side) into block seal groove. Trim excess packing flush with block. Form a new rope seal in bearing cap. Install bolts and tighten.

### CAMSHAFT

#### ENGINE FRONT COVER

**Removal** — Drain cooling system and remove radiator hoses and by-pass hose. Remove belts, fan and fan pulley, crankshaft pulley and hub. Remove front cover attaching bolts, front cover, timing indicator and water pump. Remove both dowel pins.

**Installation** — 1) Grind a chamfer on one end of dowel pin. Cut excessive material from end of oil pan gasket on each side of block. Clean all mating surfaces with solvent. Trim 1/8" from each end of new pan seal. Install new front cover gasket on block and new seal on front cover. Apply suitable sealer to gasket around coolant holes and place on block.

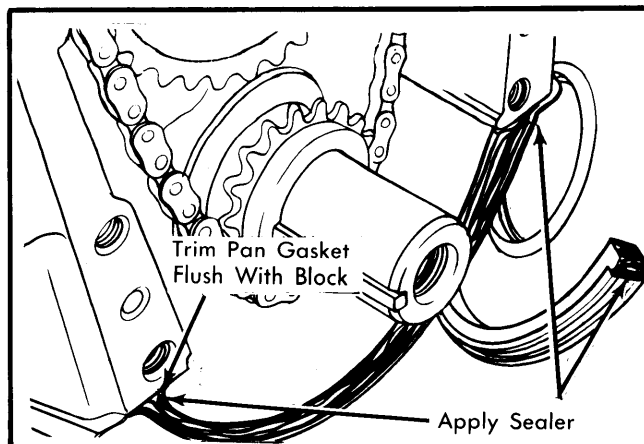

Fig. 7 Installing Pan and Front Cover Seal

2) Apply suitable sealer at junction of block, pan and front cover. See Fig. 7. Install front cover pressing downward to compress seal. Rotate cover left and right to guide pan seal into cavity using a small screwdriver. See Fig. 8.

3) Apply engine oil to bolts and install 2 bolts finger tight. Install dowel pins (chamfered end first), timing indicator and water pump. Lubricate seal surface and install crankshaft hub. Install all pulleys, fan and belts. Install radiator hoses and by-pass hose. Refill cooling system.

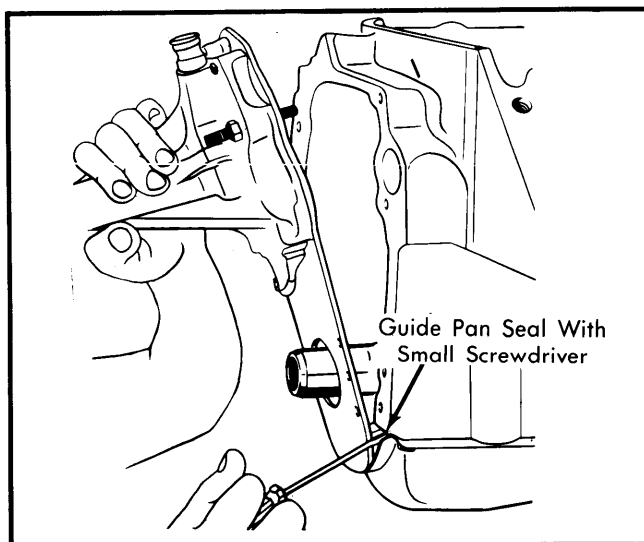

Fig. 8 Front Cover Installation

#### FRONT COVER OIL SEAL

**Removal** — With crankshaft pulley and pulley hub removed, remove seal with puller tool (BT-6406).

**Installation** — Apply sealer to outside diameter of new seal. Using seal installer tool (BT-6405), install oil seal in front cover. Tighten until a .005" (.13 mm) feeler gauge just fits between tool and front cover. Install pulley hub and crankshaft pulley. Install and adjust belts.

#### TIMING CHAIN

**Removal** — Remove front cover, fuel pump eccentric and oil slinger. Remove camshaft sprocket and timing chain. Remove crankshaft sprocket key and then crankshaft sprocket.

## 4.3 &amp; 5.0 LITER V8 (Cont.)

**NOTE** — Crankshaft sprocket may have to be removed with a puller.

**Installation** — 1) Position crankshaft so keyway points halfway between 1 o'clock and 2 o'clock positions. Install timing chain and sprockets together and align timing marks. See Fig. 9.

**NOTE** — When 2 marks are in alignment, number 6 piston is at TDC. To obtain TDC for number 1 cylinder, rotate crankshaft 1 revolution. This will bring camshaft sprocket mark to the top and number 1 piston will be in firing position.

2) Install fuel pump eccentric with flat side rearward. Drive crankshaft sprocket key into place using brass hammer until it bottoms in groove. Install oil slinger.

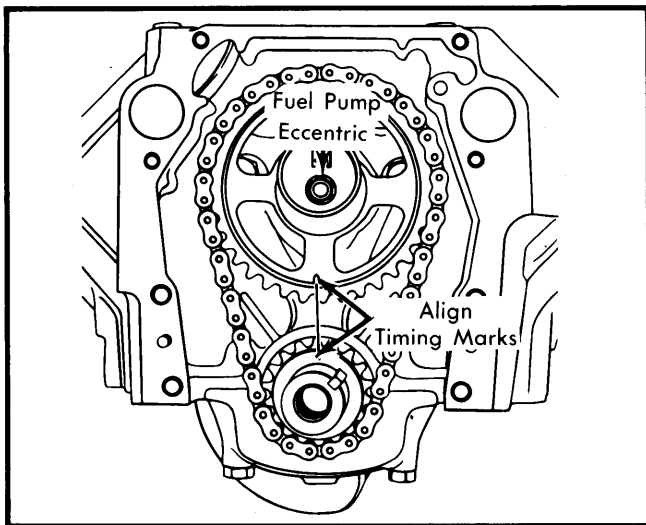

Fig. 9 Timing Chain Sprocket Alignment

## CAMSHAFT

**Removal** — 1) Disconnect battery and drain radiator. Remove upper radiator baffle, radiator hoses and support clamp. Disconnect transmission oil cooler lines at radiator. Remove radiator fan shroud and radiator. Disconnect fuel line at fuel pump, remove fuel pump.

2) Remove air cleaner and disconnect throttle cable. Remove alternator drive belt. Remove alternator mounting bracket bolts and place alternator aside. Remove power steering mounting bolts and move pump clear of engine.

3) Remove air conditioning compressor mounting bolts and water pump by-pass hose, electrical and vacuum connections. Remove distributor complete with cap and wiring. Raise vehicle and drain engine oil.

4) Remove crankshaft pulley, pulley hub and front cover. Remove valve covers. Remove intake manifold, gasket, front and rear seals, rocker arms, push rods and lifters.

**NOTE** — Keep parts in order for reassembly.

5) Discharge air conditioning system and remove condenser (if equipped). Remove fuel pump eccentric and attaching bolt, camshaft gear, oil slinger and timing chain. Carefully slide camshaft out of front of engine.

**Installation** — To install camshaft, reverse the removal procedure.

**NOTE** — Before installation, coat camshaft and bearings liberally with suitable lubricant.

## CAMSHAFT BEARINGS

**Removal** — Bearings must be replaced as a complete set. Using suitable tool (BT-6409) remove bearings in order (No. 1 first, No. 2 second, etc.).

**Installation** — To install camshaft bearings, reverse removal procedure while noting the following: To aid in aligning bearings with oil passages, place bearing in front bore with tapered edge toward block and align oil hole in bearing with center of oil slot in bore. Mark bearing. When installing bearing, mark will act as a guide. See Fig. 10.

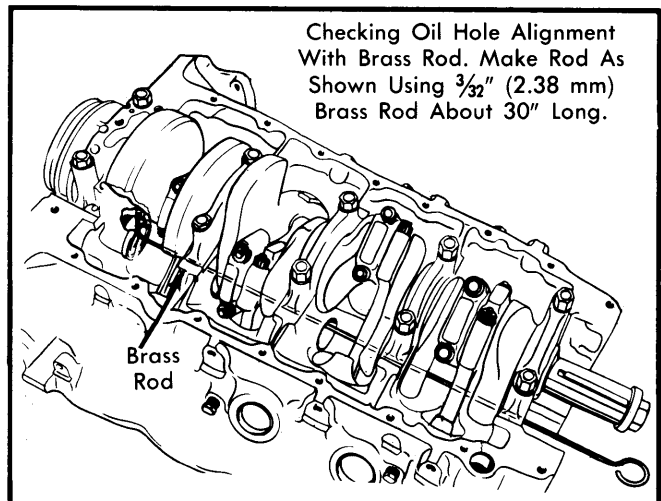

Fig. 10 Checking Oil Hole Alignment

## ENGINE OILING

**Crankcase Capacity** — 4 quarts. Add 1 quart with filter change.

**Oil Filter** — Replace filter at first oil change and every second oil change after that.

**Normal Oil Pressure** — 35 psi at 1500-3000 RPM.

**Pressure Regulator Valve** — Located in oil pump cover. Not adjustable.

## ENGINE OILING SYSTEM

Oil pump is mounted on rear main bearing cap in crankcase with full flow filter on right side of crankcase. Oil from filter flows through passages at rear of block to rear end of right main oil gallery and through "V" passage at front of engine to left main oil gallery. Oil distribution is as follows:

**Crankshaft & Camshaft Bearings** — Rear crankshaft and camshaft bearings are lubricated by a vertical passage intersecting horizontal cross passage from oil filter. Other crankshaft and camshaft bearings are lubricated by a "V" shaped oil passage in each crankcase web.

## 4.3 & 5.0 LITER V8 (Cont.)

**Valve Lifters** — Each lifter supplied with oil through short passage leading upward from right and left main galleries at point directly below lifter.

**Rocker Arms, Push Rods & Valves** — Hollow push rods are supplied with oil through hole in valve lifter push rod seat.

**Distributor Drive Gear** — Lubricated from drilled hole in plug at rear end of left main oil gallery.

**Timing Chain & Sprockets** — Lubricated from drilled hole in hexagonal headed plug which closes front end of right main oil gallery.

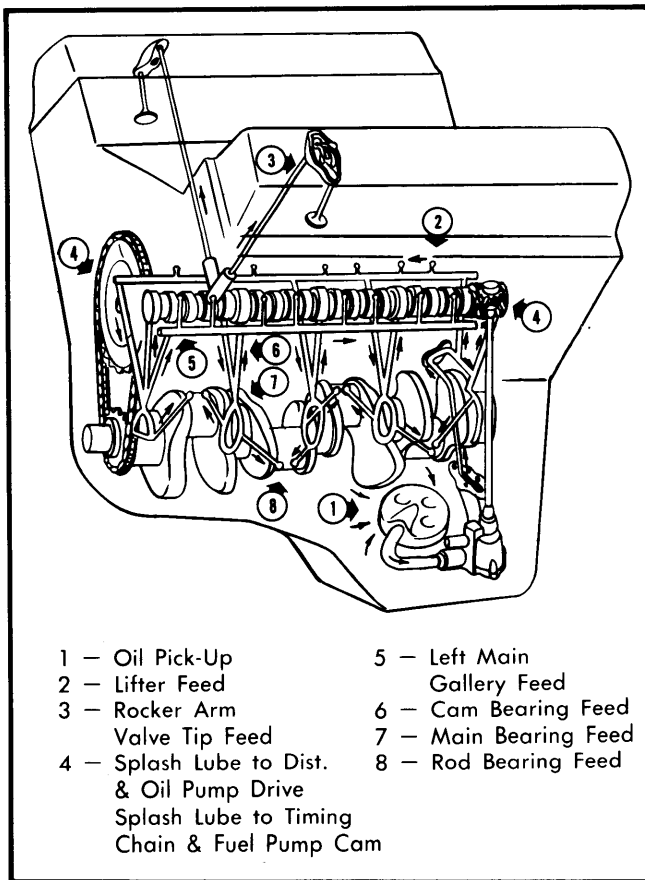

Fig. 11 Engine Oiling System

### OIL PUMP

**Oil Pump Removal & Installation** — Remove oil pan. Remove the oil pump-to-rear main bearing cap attaching bolts, then remove pump and drive shaft extension. Reverse procedure to complete installation.

**Disassembly** — Remove oil pump drive shaft extension. Place thumb over pressure regulator valve bore and remove cotter pin, spring and pressure regulator valve. Remove oil pump cover screws, cover and gasket. Remove drive gear and idler gear from pump body. See Fig. 12.

**NOTE** — Do not remove washers from drive shaft extension. Also, use care when removing cotter pin, as spring is under pressure.

**Reassembly** — 1) Install idler and drive gear in pump body. Check gear end clearance by placing straightedge over gears and measuring clearance between straightedge and gasket surface. Clearance should be .0015-.0085" (.038-.215 mm).

2) If end clearance is near top reading, check for scores in cover that would bring total clearance over specified amount. Regulator valve-to-bore clearance should be .0025-.0050" (.064-.127 mm). Reinstall pressure regulator valve, spring and cotter pin.

**NOTE** — When installing extension, the end nearest washer must be inserted into drive shaft. Make sure washer is 1 11/32" (34 mm) from end of shaft.

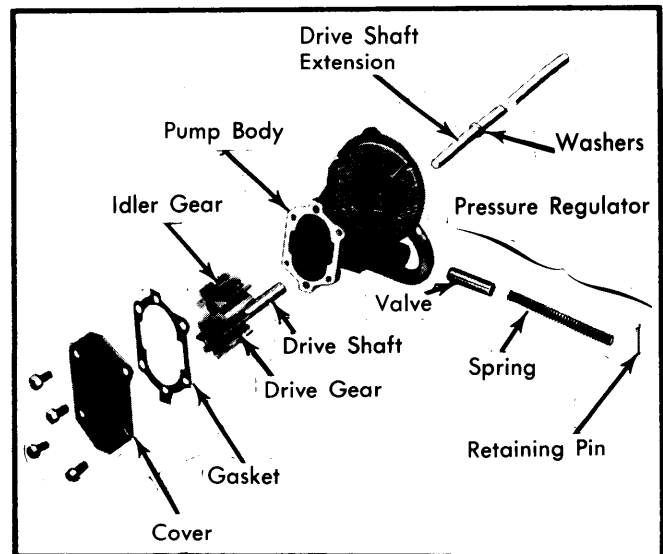

Fig. 12 Exploded View of Oil Pump Assembly

## ENGINE COOLING

### WATER PUMP

**Removal** — Disconnect negative battery cable and drain cooling system. Disconnect lower radiator hose at water pump. Disconnect heater hose and by-pass at water pump (if so equipped). Remove fan assembly and all pulley belts. Remove water pump pulley. Disconnect alternator, A/C compressor and power steering brackets. Remove water pump attaching bolts and remove water pump. Clean all surfaces to ensure proper seal.

**Installation** — If installing new water pump, transfer pulley from old pump. Apply a 1/8" bead of sealant to water pump sealing surface. While sealant is wet, install water pump and tighten attaching bolts. Install all accessory drive belts and connect negative battery cable.

**NOTE** — For further information on cooling system capacities and other cooling system components, see appropriate article in ENGINE COOLING SYSTEMS section.

# General Motors V8 Engines

## 4.3 & 5.0 LITER V8 (Cont.)

### ENGINE SPECIFICATIONS

GENERAL SPECIFICATIONS									
Engine	HP at RPM	Torque (Ft. Lbs. at RPM)	Compr. Ratio	Bore		Stroke		Displ.	
				in.	mm	in.	mm	cu. ins.	cc
4.3L (260")	100@3600	190@1600	8.0:1	3.50	88.9	3.38	85.9	260	4300
5.0L (307")	140@3600	240@1600	8.5:1	3.80	96.5	3.38	85.9	307	5000

VALVES							
Engine & Valve	Head Diam. In. (mm)	Face Angle	Seat Angle	Seat Width In. (mm)	Stem Diameter In. (mm)	Stem Clearance In. (mm)	Valve Lift In. (mm)
4.3L (260") Int.	1.517-1.527 (38.53-38.79)	44°	45°	.037-.075 (.94-1.91)	.3425-.3432 (8.70-8.72)	.0010-.0027 (.025-.069)	.396 (10.06)
Exh.	1.295-1.305 (32.89-33.15)	30°	31°	.050-.090 (1.27-2.29)	.3420-.3427 (8.69-8.70)	.0015-.0032 (.038-.081)	.400 (10.16)
5.0L (307") Int.	1.745-1.755 (44.32-44.57)	44°	45°	.037-.075 (.94-1.91)	.3425-.3432 (8.70-8.72)	.0010-.0027 (.025-.069)	.400 (10.16)
Exh.	1.497-1.507 (38.02-38.28)	30°	31°	.050-.090 (1.27-2.29)	.3420-.3427 (8.69-8.70)	.0015-.0032 (.038-.081)	.400 (10.16)

PISTONS, PINS, RINGS						
Engine	PISTONS		PINS		RINGS	
	Clearance In. (mm)	Piston Fit In. (mm)	Rod Fit In. (mm)	Rings	End Gap In. (mm)	Side Clearance In. (mm)
4.3L & 5.0L (260 & 307")	.00075-.0017 (.019-.043)	.0003-.0005 (.008-.013)	.0008-.0018 (.020-.046)	No. 1	.009-.019 (.23-.48)	.002-.004 (.051-.102)
				No. 2	.008-.019 (.23-.48)	.002-.004 (.051-.102)
				No. 3	.015-.055 (.38-1.40)	.001-.005 (.025-.127)
			Press Fit			

CRANKSHAFT MAIN & CONNECTING ROD BEARINGS							
Engine	MAIN BEARINGS				CONNECTING ROD BEARINGS		
	Journal Diam. In. (mm)	Clearance In. (mm)	Thrust Bearing	Crankshaft End Play In. (mm)	Journal Diam. In. (mm)	Clearance In. (mm)	Side Play In. (mm)
All	①2.4990-2.4995 (63.47-63.49)	②.0005-.0021 (.013-.053)	No. 3	.0035-.0135 (.089-.343)	2.1238-2.1248 (53.94-54.10)	.0004-.0033 (.010-.084)	.006-.020 (.152-.510)

① — No. 1 journal diameter is 2.4994-2.4998" (63.48-63.49 mm).

② — No. 5 bearing clearance is .0015-.0031" (.038-.079 mm).

## 4.3 & 5.0 LITER V8 (Cont.) ENGINE SPECIFICATIONS (Cont.)

VALVE SPRINGS			
Engine	Free Length In. (mm)	PRESSURE Lbs. @ In. (kg @ mm)	
		Valve Closed	Valve Open
All Models	1.95 (49.5)	76-84@1.67 (36.4@42.42)	180-194@1.27 (85@32.26)

CAMSHAFT			
Engine	Journal Diam. In. (mm)	Clearance <sup>①</sup> In. (mm)	Lobe Lift In. (mm)
All	②2.0357-2.0365 (51.71-51.73)	.0020-.0058 (.051-.147)	③.400 (10.16)

- ① — End play is .011-.077" (.28-1.96 mm).
- ② — No. 1 journal. Each succeeding journal is .020" (.51 mm) smaller than preceding journal.
- ③ — 4.3L (260") engine Int. is .396" (10.06 mm).

TIGHTENING SPECIFICATIONS	
Application	Ft. Lbs. (N·m)
Cylinder Head Bolts	
4.3L (260") .....	① ④85 (115)
5.0L (307") .....	② ④125 (169)
Intake Manifold Bolts .....	③ ④40 (54)
Exhaust Manifold Bolts .....	25 (34)
Main Bearing Cap Bolts	
All Except Rear Main No. 5 .....	80 (108)
Rear Main No. 5 .....	120 (163)
Connecting Rod Cap Nuts .....	42 (57)
Harmonic Balancer Bolt .....	200-310 (271-420)
Oil Pump-to-Main Cap Bolt .....	35 (47)
Rocker Arm Pivot Bolts .....	28 (38)
Camshaft Sprocket Bolt .....	65 (88)
Flywheel-to-Crankshaft Bolts (Auto. Trans.) .....	60 (81)
Water Pump .....	13 (18)

- ① — Tighten in 2 steps (step 1 is 60 ft. lbs., 81 N·m).
- ② — Tighten in 2 steps (step 1 is 100 ft. lbs., 135 N·m).
- ③ — Tighten in 2 steps (step 1 is 15 ft. lbs., 20 N·m).
- ④ — Dip in engine oil for proper torque.