

## 1.7 LITER 4-CYLINDER

## IDENTIFICATION CODING

## ENGINE IDENTIFICATION

Engine may be identified from the Vehicle Identification Number (VIN) stamped on a gray colored metal tab, which is located on top of instrument panel at lower left of windshield. VIN number code also appears as part of a production or unit number stamped on left rear of cylinder block, below cylinder head. The engine number is stamped on a pad above fuel pump on cylinder block. The VIN number contains 17 digits. The 8th digit identifies the engine and the 10th digit establishes the model year.

Engine Code	
Engine	Code
1.7L (105") 2-Bbl. ....	A

## ENGINE REMOVAL

See *Engine Removal* at end of ENGINE Section.

## CYLINDER HEAD &amp; MANIFOLDS

## INTAKE &amp; EXHAUST MANIFOLDS

**Removal** — 1) Disconnect battery cable. Remove air cleaner. Disconnect all vacuum lines, electrical wiring and fuel line from carburetor. Remove throttle linkage.

2) Loosen power steering pump and remove belt. Raise vehicle and remove exhaust pipe from manifold. Remove power steering pump and set aside. Remove intake and exhaust manifold retaining nuts and screws. Lower vehicle and remove carburetor and manifold assembly and separate.

**Installation** — To install, reverse removal procedure.

## CYLINDER HEAD

**NOTE** — Due to light alloy used in cylinder head, engine MUST be cold before removal. If engine is hot, cylinder head could warp.

**Removal** — 1) Drain cooling system and remove intake and exhaust manifolds. Remove camshaft cover, timing belt cover and timing belt from camshaft sprocket. Remove camshaft bearing caps 5, 1 and 3 first. Then diagonally loosen and remove bearing caps 2 and 4, and remove camshaft.

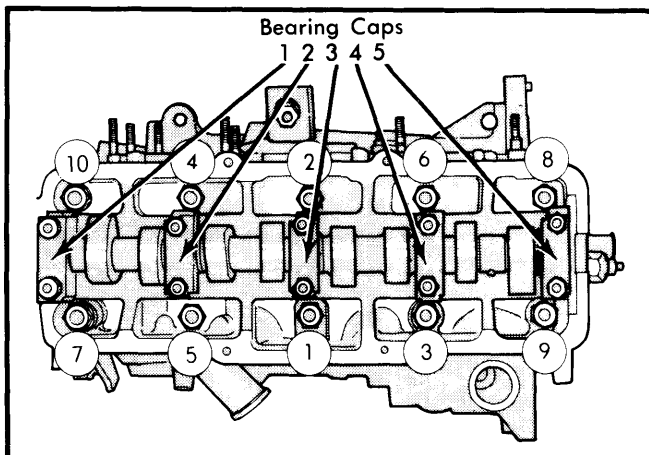

**Fig. 1** Cylinder Head Tightening Sequence  
(Loosen in Reverse Order — No. 10 to 1)

2) Identify all parts being removed, for reinstallation in original position. Remove cylinder head bolts in reverse order (number 10 to number 1) of installation. Remove cylinder head and gasket.

**CAUTION** — To prevent breakage of camshaft, be sure to remove bearing caps 5, 1 and 3 first. Then diagonally loosen and remove bearing caps 2 and 4.

**Installation** — Check cylinder head and cylinder block for distortion. If more than .004" (.10 mm) distortion on either cylinder head or block, surface cylinder head and/or block. Coat gasket with suitable sealer. Install gasket and head on block, making sure gasket marking "OBEN" is facing cylinder head. Insert bolts 8 and 10 to center head on block. Tighten bolts in sequence. After all bolts have been tightened to specifications, turn another 1/4 turn. See Fig. 1.

## VALVES

## VALVE GUIDE SERVICING

Insert valve with valve head positioned .40" (10 mm) above cylinder head gasket surface. Attach dial indicator to cylinder head and position against valve head at right angle to valve stem. Rock valve in guide and measure guide wear as shown on dial indicator. Maximum clearance is .020" (.50 mm) on intake valves and .027" (.70 mm) on exhaust valves. If clearance is excessive, guide(s) should be replaced and reamed to .315-.316" (8.000-8.035 mm).

**NOTE** — Do not replace valve guides in cylinder head in which valve seats cannot be refaced.

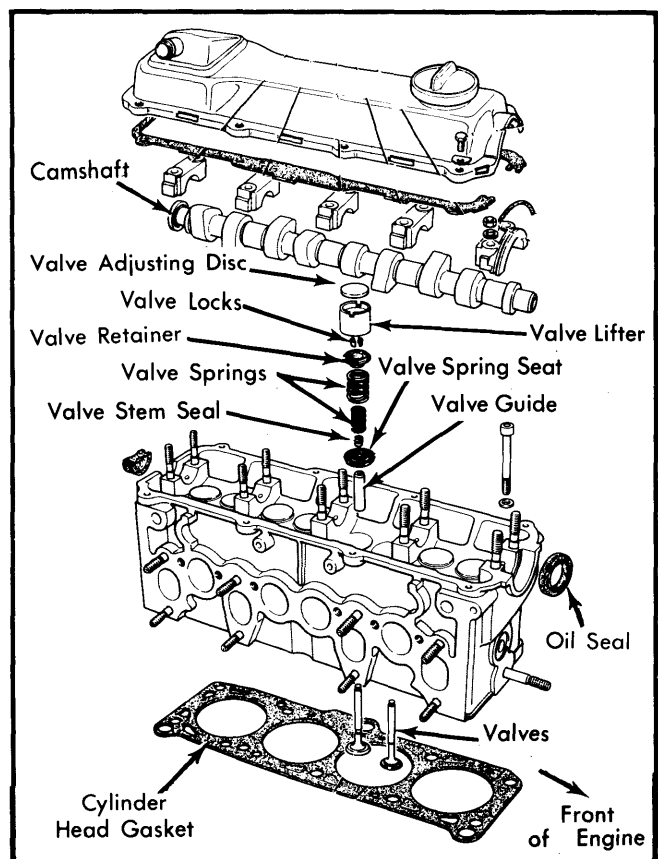

**Fig. 2** Cylinder Head and Valve Assembly

## 1.7 LITER 4-CYLINDER (Cont.)

### VALVE GUIDE REPLACEMENT

1) Using a press and a suitable guide drift, press worn guide from cylinder head working from combustion chamber side.

2) Coat new guides with oil and press into cold cylinder head from camshaft side. Press guides in as far as they will go. (Service guides have a shoulder stop.)

**NOTE** — Once guide shoulder is seated, do not use more than 1 ton pressure or guide shoulder may break.

### VALVE SPRINGS

**Removal** — 1) Remove camshaft and cam followers (valve lifters). Turn crankshaft until piston of cylinder concerned is at BDC. Remove spark plug and install air line adapter to spark plug port and apply continual compressed air to hold valves in place.

**NOTE** — Do not turn engine by turning camshaft pulley. This will stretch drive belt.

2) Using spring compressor tool (L-4419 or equivalent), compress valve spring and remove valve locks, retainer, valve springs and valve spring seats. Remove oil seal using needle nose pliers.

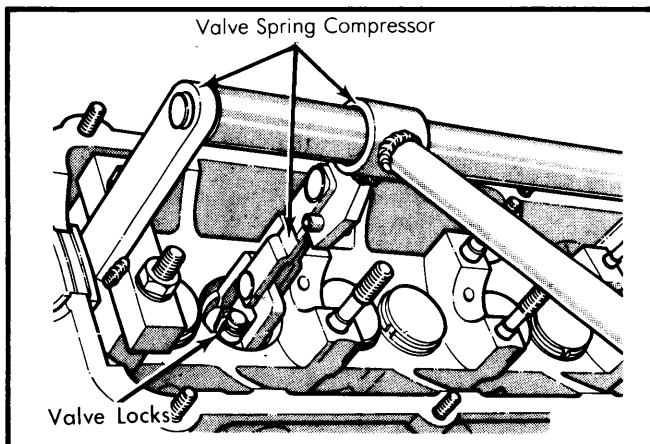

**Fig. 3 Removal and Installation of Valve Spring Assembly**

**Installation** — Inspect valve springs for wear, cracks and/or distortion. Replace as required. Reverse removal procedure to complete installation.

### VALVE STEM OIL SEAL

**NOTE** — Steel-backed rubber valve stem seals are used on all valves.

**Removal & Installation** — Use seal protector from gasket set to prevent valve keeper grooves from cutting seal. Lubricate valve stem seal and using suitable tool (L-4421), carefully push seal onto valve guide.

### MECHANICAL VALVE LIFTERS

Steel, bucket-type valve lifters surround and bear directly on the valve tips. A separate case-hardened steel disc, retained in the top of each lifter, serves as a cam lobe contact surface. These discs are selected for thickness, thereby insuring correct valve adjustment.

Discs must be installed with numbers facing down toward cam followers (valve lifters). Valve adjusting discs are available in sizes from .120-.168" (3.00-4.25 mm) in .002" (.05 mm) increments.

Installed discs that will obtain clearance as close as possible to nominal clearance. For example, if clearance measured at intake valve is .012" (.31 mm), and specified clearance is .010" (.25 mm), insert a .002" (.05 mm) disc to bring the clearance back to .010" (.25 mm).

Press cam follower down using compressor tool (L-4417). Remove valve adjusting disc with a narrow screw driver and a pencil magnet. Install new discs, check and readjust if necessary.

Valve Adjustment Clearances		
Valve	Hot	Cold
Intake .....	.010" .....	.006"
	(.25 mm)	(.15 mm)
Exhaust .....	.018" .....	.014"
	(.45 mm)	(.35 mm)

## PISTONS, PINS & RINGS

### OIL PAN

See Oil Pan Removal at end of ENGINE Section.

### PISTON & ROD ASSEMBLY

**Removal** — 1) With cylinder head and oil pan removed, use ridge reamer to remove any deposits or ridge from upper portion of cylinder bore.

**NOTE** — Piston must be at bottom of stroke and covered with cloth to collect cuttings.

2) Inspect connecting rods and caps for cylinder identification and mark as necessary for installation in original locations. Remove rod cap and push piston and rod assembly out top of block.

**Installation** — 1) Lightly coat piston rings and cylinder bores with engine oil. Make sure "TOP" mark on upper, intermediate and oil scraper rings point toward top of piston. Make sure ring gaps are properly spaced on upper and intermediate

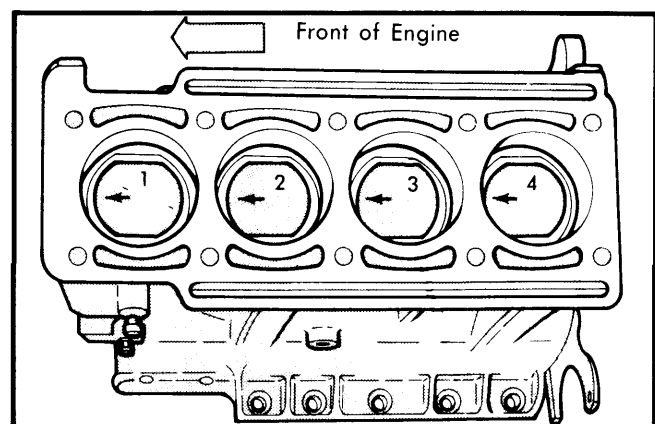

**Fig. 4 Piston and Rod Installation in Cylinder Block**

## 1.7 LITER 4-CYLINDER (Cont.)

rings, and 3-piece oil ring rail gaps are installed 180° apart from each other.

**2)** Using ring compressor, compress rings and install pistons in cylinder with arrows pointing toward timing gear (front of engine). See Fig. 4. Forged marks on connecting rods and caps must face toward intermediate shaft.

**FITTING PISTONS**

**1)** Measure cylinder bore at 3 points: 3/8" (10 mm) down from top, and 3/8" (10 mm) up from bottom of bore, and at center of bore. Measure in line with thrust face and 90° angle to thrust face. Cylinder bore wear limit is .0027" (.070 mm). Maximum out-of-round wear limit is .0016" (.040 mm).

**2)** Measure pistons 7/16" (11 mm) from bottom of piston skirt, measuring 90° to pin bore. Compare this measurement with measurement of corresponding cylinder bore and note piston-to-cylinder bore clearance. If clearance exceeds .0027" (.070 mm), oversize piston must be installed.

**FITTING RINGS**

**1)** Place cylinder block upside down. Position ring in cylinder block into bore that it will be used in and push ring into bore 5/8" (16 mm).

**2)** Measure gap between ends of ring using feeler gauge. If not to specification, substitute another ring set until rings are within specifications.

**CAUTION** — Use care to avoid damage to ring or cylinder bore.

**PISTON PINS**

**Removal & Installation** — Use drift punch to remove piston pin circlip. Push pin from piston. Reverse removal procedures to reinstall.

**CRANKSHAFT & ROD BEARINGS****MAIN & CONNECTING ROD BEARINGS**

**Connecting Rod Bearings** — **1)** Use Plastigage method to check rod bearings. Turn crankshaft until connecting rod to be checked just starts moving toward top of engine. Place Plastigage across full width of lower bearing cap 1/4" (6.35 mm) off center and away from oil holes.

**2)** Install rod cap and tighten nuts or bolts to 35 ft. lbs. (48 N•m). Remove cap and determine amount of clearance by measuring width of compressed Plastigage with scale furnished on package. Clearance should be .0004-.0025" (.010-.064 mm).

**3)** If clearance exceeds specification, new bearings must be installed. Bearings are available in standard, .010" (.250 mm), .020" (.500 mm) and .030" (.750 mm) undersize.

**4)** Check rod journal for out-of-round condition. If journals are more than .002" (.03 mm) out-of-round, crankshaft must be reconditioned or replaced. When all bearings have been checked and/or replaced, measure rod side clearance using feeler gauge. Clearance should be .015" (.37 mm).

**NOTE** — If clearance cannot be brought within specification, grind crankshaft to next size undersize. If already at maximum undersize, replace crankshaft.

**Main Bearings** — **1)** Support weight of crankshaft with jacks or stand placed under counterweight adjacent to main bearing being checked.

**2)** Remove cap and bearing. Place Plastigage across full width of bearing. Install cap with bearing and torque bolts to 47 ft. lbs.

**3)** Remove main cap. Determine amount of clearance by measuring width of compressed Plastigage with scale furnished on package. Clearance should be .0008-.0030" (.020-.080 mm). If clearance exceeds specification, new bearings must be installed. Bearings are available in standard, .010" (.250 mm), .020" (.500 mm) and .030" (.750 mm) undersize.

**NOTE** — No. 1, 2, 4 and 5 main bearing halves are installed with lubrication grooves in cylinder block.

**4)** Check crankshaft journal for out-of-round condition. If journals are more than .002" (.03 mm) out-of-round, crankshaft must be reconditioned or replaced. When all bearings have been checked and/or replaced, measure crankshaft end play using dial indicator.

**5)** Mount dial indicator on front of engine with stem on nose of crankshaft sprocket. Move crankshaft rearward and zero dial indicator. Move crankshaft all the way forward and read dial indicator reading. End play should be .003-.007" (.070-.180 mm).

**NOTE** — Some engines may be equipped with a 6-piece thrust bearing. Upon reassembly, replace with a 2-piece thrust bearing.

**CRANKSHAFT SPROCKET OIL SEAL**

**Removal** — **1)** Remove timing belt cover and remove timing belt. Remove timing belt shield bolts and crankshaft sprocket bolt. Install tool (4524-1 or equivalent) in end of crankshaft.

**2)** Install puller tool (4524-1 or equivalent) and remove crankshaft sprocket and timing belt shield. Remove oil seal using seal removal tool (L-4424 or equivalent).

**Installation** — Position new seal and seal installer tool (L-4422 or equivalent) flush with front oil seal retainer cover and install seal to depth of 3/32" (2 mm) into front oil seal retainer. Reverse removal procedure to complete installation.

**REAR MAIN BEARING OIL SEAL**

**Removal & Installation** — Transmission must be removed for seal service. Pry old seal from engine. Using a suitable oil seal installation tool (L-4455-1), install new seal. Oil lip of new seal with engine oil and tap into place with a plastic mallet.

**CAMSHAFT****TIMING BELT**

**Removal** — **1)** Disconnect battery. If equipped, remove A/C compressor and power steering pump from mounting brackets and position aside, leaving refrigerant lines and/or hoses connected. Remove alternator from mounting bracket and position aside.

**2)** Raise vehicle and remove inner fender splash shield. Remove water pump. If equipped, remove AIR pump belts. Remove idler pulley assembly. Remove crankshaft pulley and power steering belt. Remove lower plastic timing belt cover.

## 1.7 LITER 4-CYLINDER (Cont.)

3) Lower vehicle and place jack under engine. Remove right motor mount through bolt and raise engine slightly. Loosen timing belt tensioner and remove timing belt.

**Installation** – 1) Align timing marks on crankshaft and intermediate sprockets. See Fig. 5. Turn camshaft sprocket until timing mark on sprocket is lined up with camshaft cover sealing surface. See Fig. 6.

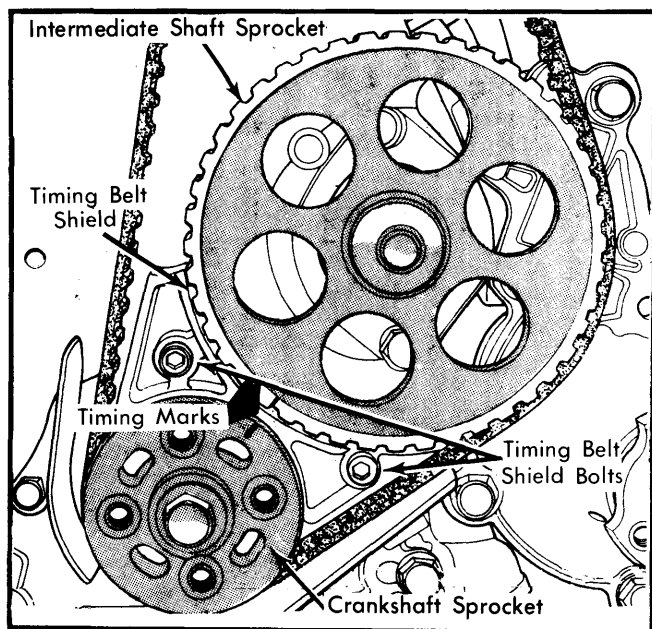

**Fig. 5 Crankshaft and Intermediate Sprocket Timing Marks**

2) Install timing belt and timing belt tensioner tool (L-4502 or equivalent) horizontally on large hex of belt tensioner pulley and loosen tensioner lock nut. If necessary, reset belt tensioner tool to have axis within 15° of horizontal.

**NOTE** – Do not turn engine by turning camshaft pulley. This will cause belt to skip teeth.

3) Turn engine clockwise from TDC 2 complete crankshaft revolutions to TDC. Tighten tensioner lock nut while holding belt tensioner wrench in position. Reverse removal procedure to complete installation.

**NOTE** – If "whirring" sound is heard from timing belt after installation, belt is too tight.

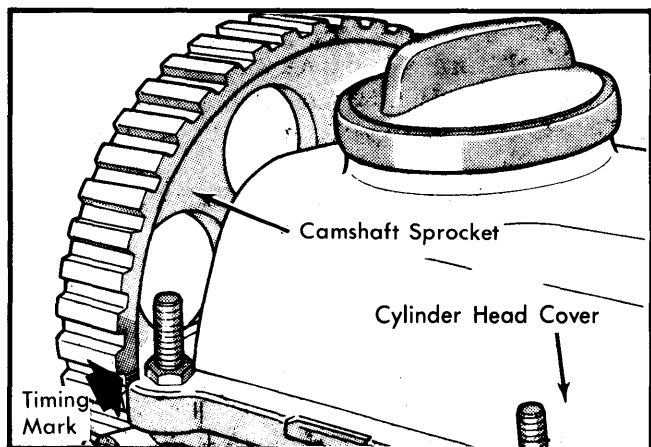

**Fig. 6 Crankshaft Timing Mark**

## CAMSHAFT

**Removal** – 1) Remove timing belt and camshaft cover. Loosen and remove bearing caps in following sequence: 5, 1 and 3. Then diagonally loosen and remove bearing caps 2 and 4. Caps are numbered from front to rear. See Fig. 1.

2) Remove camshaft, adjusting discs and cam followers. Reinstall camshaft and bearing caps No. 1 and 5. Mount dial indicator to timing gear end of camshaft and slide cam back and forth to check camshaft end play. End play should not exceed .006" (.15 mm). If end play exceeds specification, camshaft and/or cylinder head should be replaced.

**NOTE** – When installing camshaft bearing caps, observe off center bearing position and numbers on caps are not always on same side.

3) Runout should be checked on the center journal with a dial indicator. Runout should not exceed .0004" (.01 mm). Replace camshaft if runout is excessive.

**Installation** – Lube cam followers with engine oil and install in original bores. Install adjusting discs and place camshaft on cylinder head. Loosely attach No. 2 and No. 4 bearing caps. Gradually tighten caps. Install No. 5 and No. 3 bearing caps. Install new oil seal on end of camshaft and install No. 1 bearing cap. Reverse removal procedure to complete operation.

## INTERMEDIATE SPROCKET OIL SEAL

**Removal** – 1) Remove timing belt as previously described. Remove intermediate sprocket bolt. Install suitable puller tool and remove intermediate sprocket.

2) Remove oil seal using seal removal tool (L-4424 or equivalent). If necessary, remove intermediate shaft retainer bolts and remove retainer and "O" ring seal.

**Installation** – If removed, install new "O" ring seal, intermediate shaft retainer and bolts. Position new seal and seal installer tool (L-4422 or equivalent) flush with intermediate shaft retainer and install seal flush with retainer. Reverse removal procedure to complete installation.

## VALVE TIMING

See Timing Belt.

## ENGINE OILING

**Crankcase Capacity** – 4 quarts with or without filter change.

**Oil Filter** – Replace every second oil change.

**Normal Oil Pressure** – 28 psi at 2000 RPM.

**Pressure Relief Valve** – Relief valve is staked and is not serviceable.

## OIL PUMP

**Disassembly** – Clamp pump lightly in vise with shaft down. Remove hex head mounting screws from cover. Push drive shaft up and remove shaft and gear assembly. Remove driven gear and pry deflector plate off to remove strainer.

## 1.7 LITER 4-CYLINDER (Cont.)

**Inspection** — Check gear end play by placing straightedge across pump housing. Using feeler gauge, measure between gears and straightedge. Clearance should be .001-.006" (.030-.150 mm). Using feeler gauge, measure gear backlash. Clearance should be .002-.008" (.050-.200 mm). If not within specification, replace gears.

**Reassembly** — Reverse disassembly procedures and install pump in engine.

### ENGINE COOLING

#### WATER PUMP

**Removal** — Disconnect negative battery cable and remove all accessory drive belts. Remove water pump attaching bolts and remove water pump.

**Installation — 1)** If installing new water pump, transfer pulley from old pump. Clean all sealing surfaces.

**2)** Apply a 1/8" bead of sealant to water pump sealing surface. While sealer is still wet, install water pump and tighten attaching bolts. Install drive belts and connect negative cable.

**NOTE** — For further information on cooling system capacities and other cooling system components, see appropriate article in ENGINE COOLING SYSTEMS section.

### TIGHTENING SPECIFICATIONS

Application	Ft. Lbs. (N·m)
Cylinder Head⓪	60 (83)
Connecting Rod Cap	35 (48)
Main Bearing Cap	47 (65)
Camshaft Bearing Cap	14 (19)
Rocker Arm Cover	4 (6)
Oil Pump	
Long Bolts	14 (19)
Short Bolts	7 (10)
Oil Pan Bolts	6 (8)
Camshaft Sprocket Bolt	58 (80)
Crankshaft Sprocket Bolt	58 (80)
Intermediate Shaft Sprocket Bolt	58 (80)
Intermediate Shaft Retainer Bolt	18 (29)
Timing Belt Cover Screw	8 (11)
Intake-to-Exhaust Manifold	
Inboard Nuts	12 (16)
Outboard Nuts	17 (23)
Exhaust Manifold Stud Nuts	17 (23)
Intake Manifold Bolts	17 (23)
Water Pump Bolts	30 (41)
⓪ — Then tighten an additional 1/4 turn.	

### ENGINE SPECIFICATIONS

#### GENERAL SPECIFICATIONS

Engine	HP at RPM	Torque (Ft. Lbs. at RPM)	Compr. Ratio	Bore		Stroke		Displ.	
				in.	mm	in.	mm	cu. ins.	cc
1.7L	63 @ 5200	83 @ 2400	8.2:1	3.13	79.5	3.40	86.4	105	1700

#### CRANKSHAFT MAIN & CONNECTING ROD BEARINGS

Engine	MAIN BEARINGS				CONNECTING ROD BEARINGS		
	Journal Diam. In. (mm)	Clearance In. (mm)	Thrust Bearing	Crankshaft End Play In. (mm)	Journal Diam. In. (mm)	Clearance In. (mm)	Side Play In. (mm)
1.7L (105")	2.1236-2.1244 (53.94-53.96)	.0008-.0030 (.020-.080)	No. 3	.003-.007 (.07-.18)	1.8087-1.8094 (45.94-45.96)	.001-.003 (.028-.088)	.015⓪ (.37)

⓪ — Maximum clearance permitted.

#### PISTONS, PINS, RINGS

Engine	PISTONS	PINS		RINGS		
	Clearance In. (mm)	Piston Fit In. (mm)	Rod Fit In. (mm)	Rings	End Gap In. (mm)	Side Clearance In. (mm)
1.7L (105")	.0004-.0015 (.011-.039)	.00004-.00035 (.001-.009)	.0004-.0008 (.011-.021)	1	.012-.018 (.30-.45)	.0016-.0028 (.04-.07)
				2	.012-.018 (.30-.45)	.0008-.0020 (.02-.05)
				3	.016-.055 (.40-1.40)	.008 (.20)

## 1.7 LITER 4-CYLINDER (Cont.)

### ENGINE SPECIFICATIONS (Cont.)

VALVES							
Engine & Valve	Head Diam. <sup>①</sup> In. (mm)	Face Angle	Seat Angle	Seat Width <sup>②</sup> In. (mm)	Stem Diameter In. (mm)	Stem Clearance In. (mm)	Valve Lift <sup>③</sup> In. (mm)
1.7L (105")							
Int. <sup>④</sup>	1.338 (34.0)	45°	45°	.079 (2.00)	.314 (7.97)	.020 (0.5)	.406 (10.31)
Exh. <sup>④</sup>	1.220 (31.0)	45°	45°	.094 (2.40)	.313 (7.95)	.027 (0.7)	.406 (10.31)

① - Minimum valve margin is .020" (.50 mm).

② - If seat width cannot be maintained, replace head.

③ - Measured at zero valve lash.

④ - Valves are available .020" (.50 mm) shorter in length.