

FORD MOTOR CO., CABLE OPERATED

Capri, Mustang
Cougar, Granada
Escort, Lynx
Fairmont, Zephyr

DESCRIPTION

All models use a cable operated linkage type clutch system. Clutch is a single dry disc design with a release spring type pressure plate. All models except Escort and Lynx use a pilot bearing which seats into the crankshaft. All models use a prelubricated release bearing.

REMOVAL & INSTALLATION

CLUTCH

Removal (All Except Escort and Lynx) – 1) Raise vehicle on hoist. Remove dust shield. Loosen clutch cable adjusting nuts to provide slack in cable. Disengage clutch cable from release lever. Remove cable retaining clip (if equipped) and disconnect clutch cable from flywheel housing.

2) Remove starter cable and starter from flywheel housing. Remove bolts that secure engine rear plate to front lower part of flywheel housing. Remove transmission and housing. Remove release lever from housing by pulling it through window in housing until retainer spring is disengaged from pivot.

3) Loosen the six pressure plate cover attaching bolts evenly to avoid distorting cover. If same pressure plate and cover are to be reinstalled, mark cover and flywheel so cover can be reinstalled in original position. Remove pressure plate and clutch disc from flywheel.

Installation (All Except Escort and Lynx) – 1) Install clutch release lever if removed. Position clutch disc and pressure plate assembly on flywheel. The 3 dowel pins on flywheel must be aligned with pressure plate. Bent, damaged or missing dowels must be replaced. Align clutch disc with alignment tool, then alternately and evenly tighten cover bolts.

2) Apply a light film of lithium base grease (C1AZ-19590-B) to the following surfaces: Outside diameter of transmission front bearing retainer, release lever fork and anti-rattle spring where they contact the release bearing hub, and release bearing surfaces that contact pressure plate release fingers. Fill grease groove of release bearing hub with the same grease. Be sure that there is no excess grease anywhere on assembly. From this point, install by reversing removal procedure.

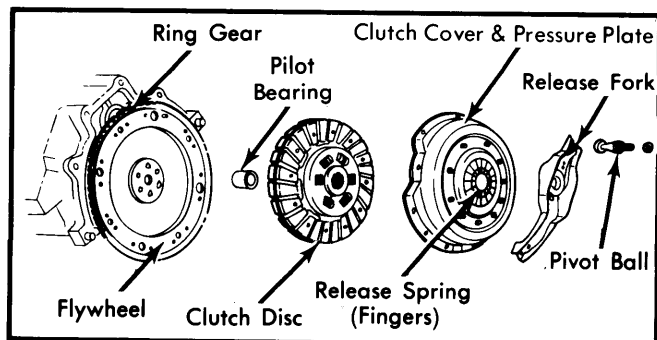

**Fig. 1 Exploded View of Clutch Assembly
(All Models Except Escort and Lynx)**

Removal (Escort and Lynx) – With transaxle removed, loosen 6 pressure plate cover bolts evenly to prevent distortion of cover. If same pressure plate and cover are to be reused, mark cover and flywheel so pressure plate can be reinstalled in original position. Remove pressure plate and clutch disc from flywheel.

Installation (Escort and Lynx) – 1) Position clutch disc and pressure plate assembly on flywheel. Assemble clutch disc so flatter side is toward flywheel as stamped. Align 3 dowel pins on flywheel with pressure plate. Bent, missing or damaged dowel pins must be replaced.

2) Start cover attaching bolts but do not tighten. Align clutch disc with alignment tool (T81P-7550-A), inserted in crankshaft. Alternately and evenly tighten cover bolts. Remove alignment tool. Install transaxle.

CLUTCH CABLE

Removal (All Except Escort and Lynx) – 1) Lift clutch pedal to its upper most position to remove pawl and quadrant. Push quadrant forward and unhook cable, allowing quadrant to slowly swing back.

2) Open hood and remove screw holding cable assembly isolator to dash panel. Pull cable through dash panel into engine compartment. Raise vehicle on hoist.

3) Remove dust cover from bell housing. Remove rubber plug in clutch release lever. Remove retainer holding cable to clutch housing.

4) Slide ball on end of cable through hole in release lever and remove cable. Remove dash panel isolator from cable.

Installation (All Except Escort and Lynx) – To install, reverse removal procedures and check clutch operation. Depress pedal several times to adjust cable.

Removal (Escort and Lynx) – 1) Grasp tip of clutch cable with pliers and unhook cable from release lever. Remove fresh air duct next to clutch pedal (if equipped). Remove shield from brake pedal support bracket.

2) Lift up on clutch pedal to release pawl and push quadrant forward. Unhook cable from quadrant and allow quadrant to swing rearward.

3) Pull cable out through recess between clutch pedal and gear quadrant, and from isolator on rear quadrant. Pull cable out through engine compartment.

Installation (Escort and Lynx) – To install, reverse removal procedures, and push pedal several times to adjust cable.

CLUTCH PILOT BEARING

NOTE – Escort and Lynx do not require a pilot bearing.

Removal & Installation – Remove transmission, clutch pressure plate and disc. Pull pilot bearing from crankshaft using a suitable slide hammer puller. To install new bearing, coat pilot bearing bore in crankshaft with a small quantity of lithium based grease. Avoid using too much grease as it may be thrown onto the disc. Using a suitable driver, carefully install bearing with seal end facing transmission.

FORD MOTOR CO., CABLE OPERATED (Cont.)

CLUTCH PEDAL ADJUSTING ASSEMBLY

Removal (All Except Escort and Lynx) — 1) Disconnect negative battery cable. Remove steering wheel. Remove lower dash panel section to left of column. Remove shrouds from column. Disconnect brake light switch and master cylinder push rod from brake pedal.

2) Unhook clutch cable from quadrant. Remove bolt holding brake pedal lateral support brace to left side of vehicle. Disconnect electrical connections to steering column.

3) Remove nuts holding brake pedal support to steering column and lower column to floor. Remove nuts holding brake pedal support bracket to dash panel.

4) Remove bolts holding support bracket to underside of instrument panel and remove support bracket. Remove clutch pedal shaft nut and remove pedal.

5) Slide self-adjusting mechanism out of support bracket. Remove adjusting mechanism shaft bushings from either side of support bracket and replace if worn.

Installation (All Except Escort and Lynx) — To install, reverse removal procedure and note the following: Lubricate self-adjusting mechanism shaft with motor oil. Check steering column for proper operation. Depress clutch pedal several times to adjust cable.

Removal (Escort and Lynx) — 1) With clutch cable removed as previously described, remove 3 nuts securing clutch pedal stop bracket to brake pedal support bracket. Remove clutch pedal assembly.

2) Remove nut attaching stop mounting bracket to pedal and remove pedal. Remove gear quadrant spring from pedal recess and pivot bolt from pedal. Remove spring washers, bushings, pivot sleeve and gear quadrant. Remove pawl pivot pin retaining clip, pivot pin, tension spring and pawl.

Installation (Escort and Lynx) — To install, reverse removal procedure and note the following: Lubricate pawl pivot pin and quadrant pivot spacer. Ensure spring washer is functional and not trapped under pivot sleeve.

TIGHTENING SPECIFICATIONS

Application	Ft. Lbs.
All Except Escort and Lynx	
2.3L Engine	
Flywheel-to-Crankshaft	75-85
Pressure Plate-to-Flywheel	12-24
Flywheel Housing-to-Engine	28-38
200" & 302" Engine	
Flywheel-to-Crankshaft	75-85
Pressure Plate-to-Flywheel	12-20
Flywheel Housing-to-Engine	38-55
Escort and Lynx	
Clutch Housing-to-Engine	28-38
Pressure Plate-to-Flywheel	12-24
Release Fork Bolt	12-24
Clutch Pedal-to-Support Bracket	15-25
Stop Mounting Bracket-to-Clutch Pedal	15-25
Flywheel-to-Crankshaft	59-69

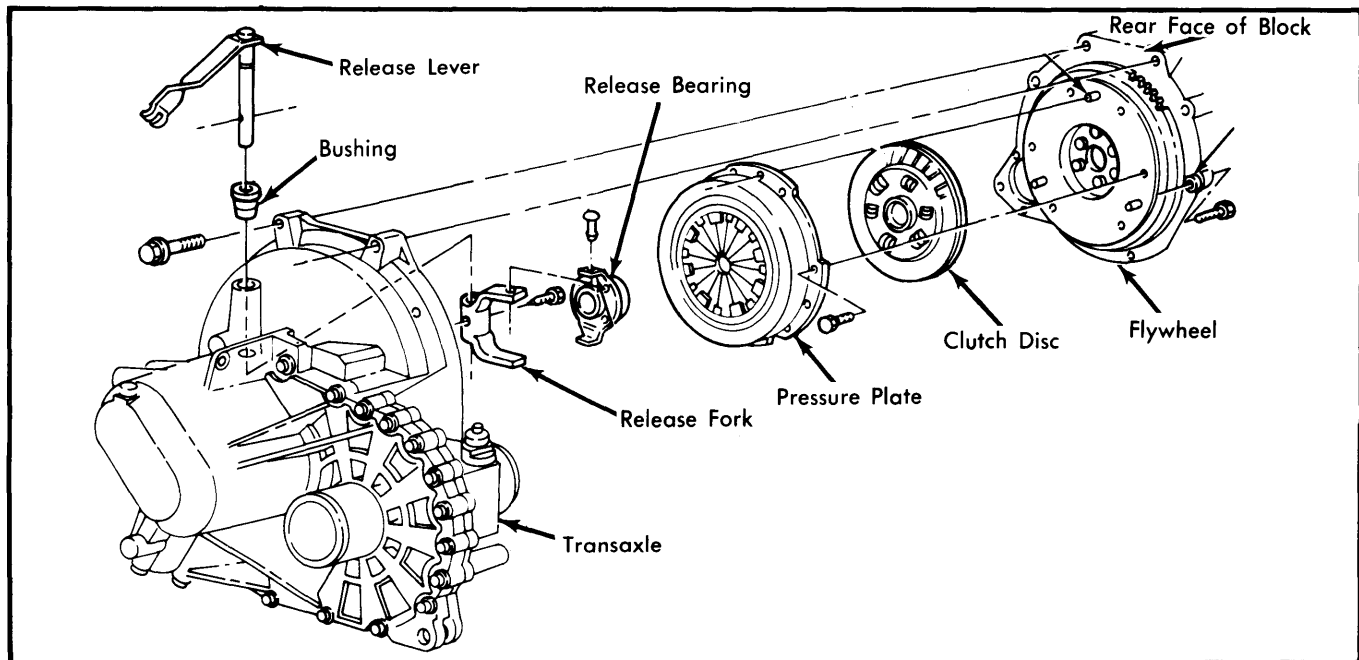

Fig. 2 Exploded View of Clutch Assembly (Escort and Lynx Models)