

1.6 LITER 4 CYLINDER

IDENTIFICATION CODING

ENGINE IDENTIFICATION

Engine may be identified from the official Vehicle Identification Number. Number is stamped on a metal tab fastened to the instrument panel close to windshield on drivers side of car and visible from outside. The eighth digit is the engine identification number.

Engine Code	
Engine	Code
1.6L (98") 2-Bbl.	2

ENGINE REMOVAL

See *Engine Removal at end of ENGINE Section.*

CYLINDER HEAD & INTAKE MANIFOLD

INTAKE MANIFOLD

Removal - 1) Disconnect negative cable at battery. Drain cooling system and disconnect heater hose located under intake manifold. Disconnect upper radiator hose at cylinder head and disconnect wiring terminal from the cooling fan switch.

2) Remove air cleaner and disconnect necessary vacuum hoses. Disconnect wiring connectors at choke cap wire, bowl vent and idle fuel solenoid.

3) Remove EGR supply tube. Raise vehicle and remove PVS hose connectors, using tool T81P-8564-A (or equivalent). Label connectors and set aside.

4) Remove the bottom 3 intake manifold nuts, locations, 2, 3 and 6. See Fig. 1. Lower vehicle. Disconnect fuel lines.

5) Disconnect accelerator and, if equipped, speed control cable. If equipped with power steering, remove thermactor pump drive belt, the pump, pump mounting bracket and thermactor by-pass hose.

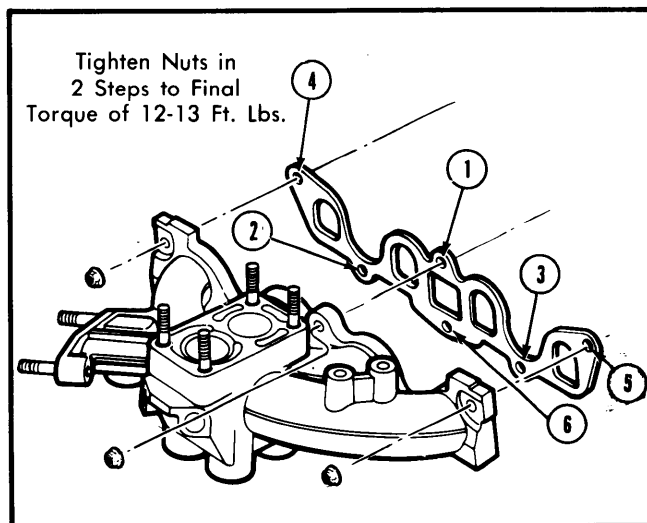

Fig. 1 1.6L Engine Intake Manifold Tightening Sequence

6) Remove fuel pump as follows: loosen fuel pump supply nut at fuel pump outlet. Loosen fuel pump mounting bolts 2 turns and manually rotate engine to position pump push rod on the low side of cam. Disconnect fuel lines. Disconnect pump mounting bolts and remove fuel pump and push rod.

7) Remove remaining intake manifold attaching nuts. Remove intake manifold and gasket, using wrench T81P-9425-A (or equivalent) on center (No. 1 position) nut.

Installation - Clean all mating surfaces on manifold and on cylinder head. Tighten nuts in 2 steps as shown in Fig. 1. To complete installation, reverse removal procedure.

CYLINDER HEAD

Removal - 1) Disconnect negative cable at battery and partially drain cooling system. Disconnect heater hose located under intake manifold.

2) Remove air cleaner assembly and PCV hose. Disconnect required vacuum hoses. Remove rocker arm cover and disconnect all necessary drive belts. Remove crankshaft pulley.

3) Remove timing belt cover and set engine No. 1 cylinder to TDC. Remove timing belt and discard. Loosen both belt tensioner bolts. Using tool T81P-6254-A (or equivalent), secure belt tensioner as far left as possible.

4) Disconnect EGR tube. Disconnect PVS hose connectors, label and set aside. Disconnect choke cap wire and fuel lines.

5) Disconnect accelerator cable and, if equipped, speed control cable. Disconnect altitude compensator (if equipped) from dash panel.

6) Disconnect alternator air intake tube and alternator wiring harness. Then remove alternator and bracket. If equipped with power steering, remove thermactor pump drive belt, pump and pump mounting bracket.

7) Raise vehicle, disconnect exhaust system and lower vehicle.

8) Remove cylinder head bolts and washers and discard bolts. Cylinder head bolts cannot be tightened to specified torque more than once and must therefore be replaced when installing a cylinder head. Remove cylinder head and gasket with intake and exhaust manifolds attached.

NOTE - Each time timing belt tensioner is released or belt is removed, a new belt must be installed.

Installation - 1) Clean all gasket material from mounting surfaces on block and head. Before installing cylinder head, crankshaft must be rotated so that No. 1 piston is 90° BTDC. To position piston, turn crankshaft until pulley keyway is at 9 o'clock.

2) Position No. 1 piston to TDC prior to installing timing belt. To time valve train to this position turn camshaft until keyway is at 6 o'clock position.

3) Position cylinder head and gasket on cylinder block. Apply Loctite (or equivalent) to all new bolts. Install new bolts and washers. Tighten attaching bolts in 4 steps, as follows: Torque all bolts to 15-30 ft. lbs. then retorque all bolts to 30-44 ft. lbs. Rotate all bolts clockwise an additional 90°. Again rotate all

1.6 LITER 4 CYLINDER (Cont.)

bolts an additional 90° clockwise. All steps are made in sequence shown in Fig. 2. Reverse removal procedure to replace all remaining components.

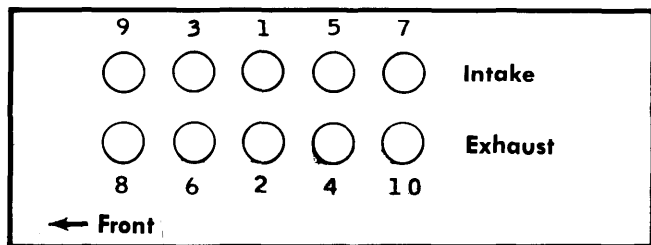

Fig. 2. Cylinder Head Bolt Tightening Sequence

VALVES

VALVE ARRANGEMENT

Left Side – All Exhaust

Right Side – All Intake

VALVE GUIDES

1) If valve guides become worn, they may be reamed to install a new valve with oversize stem. When going from a standard size stem to oversize always use reamers in sequence to obtain final desired bore.

2) Valve seats must be refaced after guide has been reamed, and a suitable tool used to break sharp corner (I.D.) of guide.

3) If it becomes necessary to ream a valve guide to install a valve with an oversized stem, a hand reaming kit, Rotunda 14-0224 (or equivalent) which contains oversized pilots and reamers is available.

VALVE STEM OIL SEALS

1) Oil seals are used on all valve stems and should be replaced whenever valve spring is removed or valve service is performed.

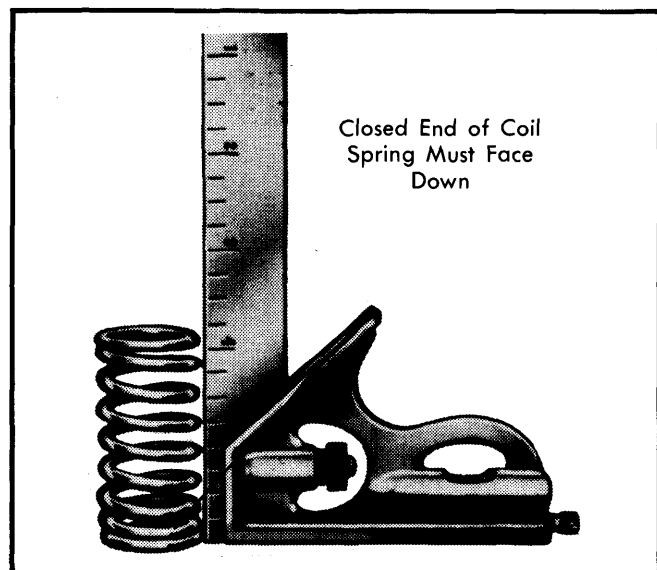

Fig. 3 Checking Valve Spring Squareness

2) Valve stem seals can be replaced with cylinder head attached through use of a suitable spring compressor, (T81P-6513-A). Compressed air must be used to hold valve against seat by installing an air line and adapter in spark plug hole.

3) Remove rocker arm from valve spring to be compressed. Position compressor under rocker arm nut and over valve spring seal. Compress valve spring and remove components as necessary.

VALVE SPRINGS

1) With valve spring removed, check length under specified load in a valve spring tester. Check valve spring free length, if less than specified replace spring.

2) Check each valve spring for squareness using a steel square as shown in Fig. 3. If spring is out of square more than .60", replace spring.

ROCKER ARM

Check rocker arm pad, side rails and fulcrum seat for excessive wear, cracks, nicks or burrs. Discard rocker arm flange nuts when rocker arms are disassembled.

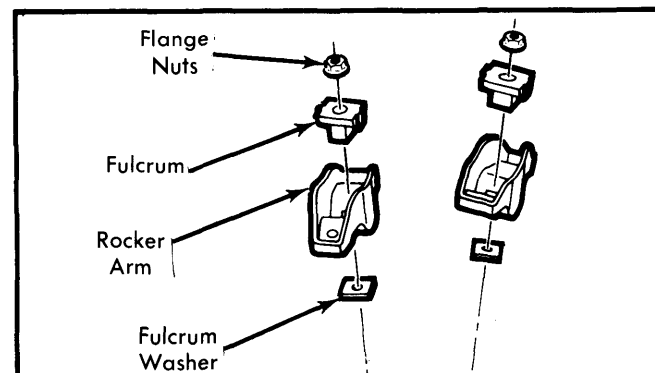

Fig. 4 Exploded View of Rocker Arms

HYDRAULIC LIFTER ASSEMBLIES

Hydraulic lifter assemblies should be kept in sequence and installed in original locations. If any part of lifter assembly is defective, entire lifter should be replaced. Do not intermix internal lifter parts. Assemble lifters and check free operation by pressing down on caps. Lifters may also be checked with hydraulic tester to check leakdown rate.

PISTONS, PINS & RINGS

OIL PAN

See *Oil Pan Removal* at end of ENGINE Section.

PISTON & ROD ASSEMBLY

Removal – 1) Remove ridge on top of cylinder bores (using suitable ridge reamer) before removing pistons from block.

2) Rotate crankshaft and identify connecting rods and rod caps for cylinder identification, mark if necessary. Remove rod caps and push each piston and rod assembly out top of cylinder bore. Install rod caps on mating rods.

1.6 LITER 4 CYLINDER (Cont.)

Installation — 1) Coat piston rings and cylinder walls with a light coat of engine oil. Position ring gaps as shown in Fig. 5. Arrow on top of piston should be pointing towards front of engine. Number on side of connecting rod and rod cap must match and face exhaust manifold side of engine.

2) Tap piston into cylinder bore using a wooden handle, install rod cap and tighten. Repeat procedure for each piston assembly.

FITTING PISTONS

Check piston to cylinder bore clearance by measuring piston and bore diameters. Measure outer diameter of piston at centerline of piston pin bore and at 90° to pin bore axis. Oversize pistons are available.

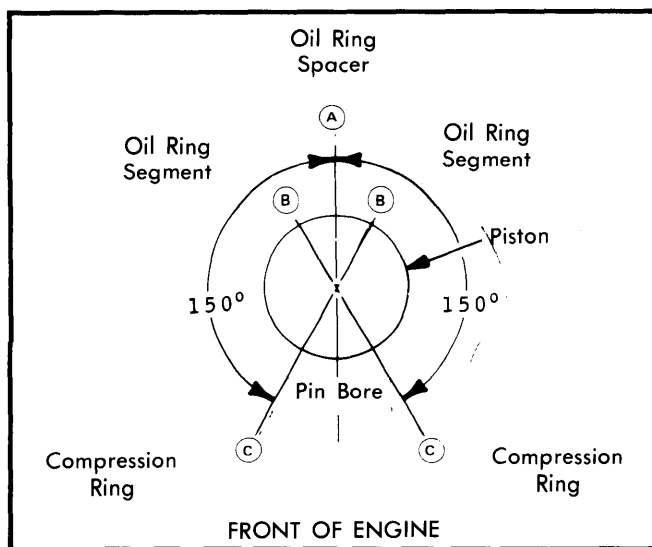

Fig. 5 Piston Ring Gap Spacing

PISTON PINS

Removal — Remove bearing inserts from connecting rod and cap. Mark piston and pin to ensure assembly with same rod. Press piston pin from piston and connecting rod using an arbor press and Piston Pin Removing and Installing Set T68P-6135-A (or equivalent).

Installation — Apply a light coat of engine oil to all parts. Assemble piston to connecting rod with cylinder number side of connecting rod and arrow on the piston dome position.

CRANKSHAFT & ROD BEARINGS**MAIN & CONNECTING ROD BEARINGS**

NOTE — Following procedures are with oil pan and oil pump removed.

Connecting Rod Bearings — After ensuring rod caps are marked for cylinder identification, remove rod caps. Use Plastigage method to check for proper clearances. If not within specifications, new bearings must be installed. New bearings are available in .001" or .002" undersize. Coat bearing surfaces with oil, install rod cap and tighten nuts.

NOTE — Always replace bearings in pairs. Never use a new bearing in combination with a used bearing.

Main Bearings — 1) Position jack under counterweight adjoining bearing being checked so weight of crankshaft will not compress Plastigage and provide an erroneous reading. With all bearing caps (other than one being checked) tight, check clearances using Plastigage method.

2) If clearances are excessive, a .001" or .002" undersize bearing may be used in combination with a standard bearing. If .002" undersized bearings are used on more than one journal, they must be positioned in cylinder block rather than bearing cap.

NOTE — Always replace bearings in pairs. Never use a new bearing in combination with a used bearing.

3) If standard and .002" undersize combinations do not bring bearing clearance within specification limits, crankshaft will have to be refinished and undersized bearings installed.

4) Remove all upper main bearings by inserting a suitable tool in oil hole of crankshaft journal and rotating crankshaft clockwise to roll bearing from engine. Lubricate new inserts, and insert plain (unnotched) side of block. Rotate bearing into place. Install all main bearing caps with arrows pointing to front of engine.

REAR MAIN BEARING OIL SEAL

Removal — Remove engine as outlined in Engine Removal Section. Remove rear cover plate and flywheel. Remove old seal using a sheetmetal screw as shown in Fig. 6, using care not to damage sealing surfaces.

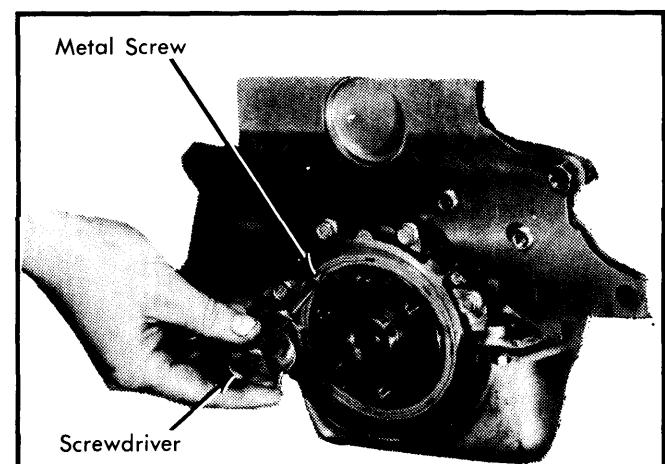

Fig. 6 Removing Crankshaft Rear Oil Seal

Installation — Inspect the crankshaft seal area for any damage that may prevent sealing and service or replace crankshaft as necessary. Coat the crankshaft seal area and seal lip with engine oil. Start seal in recess and install seal using Seal Installer (T81P-6701-A or equivalent) as shown in Fig. 7. Tighten bolts evenly so seal is straight and seats without misalignment.

1.6 LITER 4 CYLINDER (Cont.)

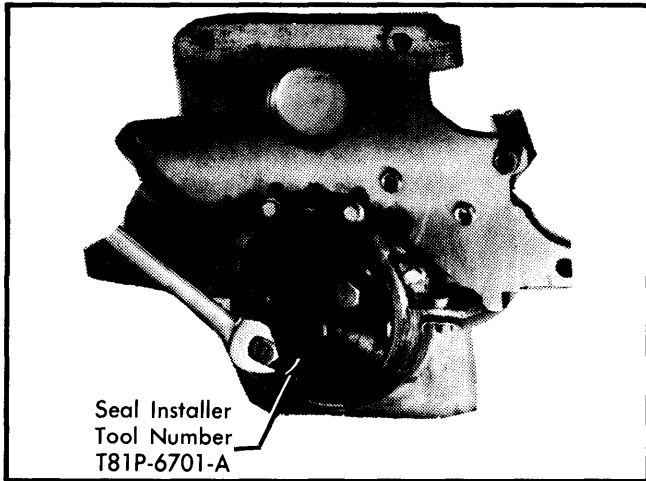

Fig. 7 Installing Rear Main Oil Seal

FRONT CRANKSHAFT OIL SEAL

Removal — Remove timing belt cover, loosen belt tensioner, remove crankshaft pulley, remove timing belt and discard. Remove crankshaft gear and timing belt guide plate, then remove seal.

Installation — Install new seal using Seal Installer (T81P-6700-A or equivalent) as shown in Fig. 8. To complete installation, reverse removal procedure.



Fig. 8 Installing Front Crankshaft Oil Seal

CAMSHAFT

CAMSHAFT

Removal — Remove timing belt cover, set engine No. 1 cylinder at TDC and remove timing belt. Remove rocker arms and hydraulic lifters. Discard rocker arm flange hex nuts. Remove distributor, camshaft sprocket and thrust plate. Remove fuel pump, fuel pump push rod, coil and coil bracket. Remove camshaft through rear of cylinder head.

Installation — Lubricate camshaft with engine oil. Install camshaft through rear of cylinder head. Install thrust plate and cam gear. Check camshaft end play and replace thrust plate, if not within specifications. Install fulcrum washer, rocker arms, fulcrum and new flange hex nuts, in order shown in Fig. 8. To complete installation, reverse removal procedures.

CAMSHAFT TIMING & BELT REPLACEMENT

Removal — 1) Whenever removing or replacing a timing belt, remove timing belt cover and align timing mark on camshaft drive sprocket with timing mark on cylinder head. Temporarily attach timing belt cover to ensure crankshaft pulley TDC mark aligns with timing mark on cover.

2) Loosen belt tensioner bolts. Pry tensioner away from belt and tighten 1 bolt. Remove crankshaft pulley and timing belt.

Installation — 1) Starting at the crankshaft install new timing belt over cogged sprockets in a counterclockwise direction. Keep belt span from crankshaft to camshaft tight as belt is installed over remaining sprockets.

2) Loosen belt tensioner bolt about 1/2 turn and allow tensioner to snap against belt. Then tighten one of the tensioner bolts.

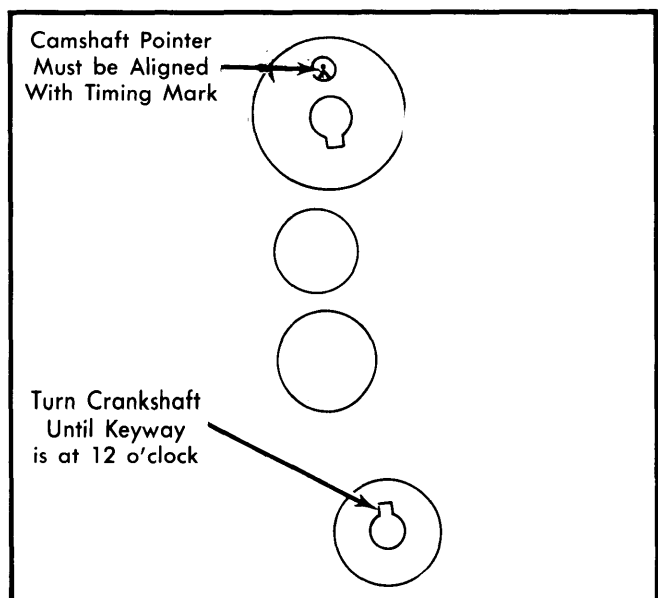

Fig. 9 Position of Camshaft and Crankshaft for Valve Timing

Ford Motor Co. 4 Engines

1.6 LITER 4 CYLINDER (Cont.)

3) With the crankshaft pulley installed, hold pulley stationary and tighten pulley attaching bolt to 74-87 ft. lbs. Rotate crankshaft 2 complete revolutions and ensure timing marks are aligned.

4) Hold crankshaft from turning, using wrench T81P6312-A (or equivalent). Apply 44-48 ft. lbs. torque to the camshaft sprocket. While holding torque, tighten the tensioner attaching bolts. When valve timing is correct, crankshaft keyway should point to 12 o'clock position and camshaft keyway to 6 o'clock as shown in Fig. 9. Do not apply torque to camshaft sprocket attaching bolt. Apply torque to hex on sprocket.

ENGINE OILING

Crankcase Capacity - 4 quarts with filter change.

Oil Filter - Full Flow, cartridge type.

Normal Oil Pressure - 40 psi at 2000 RPM (hot).

Pressure Relief Valve - Note position of relief valve plug before removal. Relief valve must be reinstalled in exactly same position. Plug threads must be sealed with anaerobic sealer (ESG M4F194-A).

ENGINE OILING SYSTEM

Engine oiling is a full pressure system. Oil pump is bolted to front of cylinder block with pump drive gear positioned directly over crankshaft. Oil pump is driven directly by crankshaft.

OIL PUMP

Removal - Remove timing belt, crankshaft pulley and gear, drain crankcase. Remove starter and oil pan. See *Oil Pan Removal at end of ENGINE Section*. Remove oil pan retaining bolts and oil pump seal. Remove oil pick up tube and screen assembly from pump and clean.

Installation - Install new oil pump seal, new oil pan gasket set. Internal components of oil pump are not serviced, if out of specification, complete pump must be replaced. Reverse removal procedures, tighten attaching bolts to proper torque as shown in Fig. 10.

TIGHTENING SPECIFICATIONS

Application	Ft. Lbs.
Belt Tensioner	17-20
Camshaft Sprocket	37-46
Camshaft Thrust Plate	7-11
Connecting Rod	19-25
Cylinder Head	
Step 1	15-30
Step 2	30-44
Steps 3 & 4	⓪
Crankshaft Pulley	74-90
Flywheel	59-69
Intake Manifold	12-13
Exhaust Manifold	15-20
Main Bearing Caps	67-80
Oil Pan	6-8
Valve Cover	6-8

⓪ - Step 3. and 4. Tighten an additional 180° clockwise in 2 Steps of 90° each.

GENERAL SPECIFICATIONS

Engine	Net HP at RPM	Torque (Ft. Lbs. at RPM)	Compr. Ratio	Bore	Stroke	Displ. Cu. Ins.
1.6L	87@6000	115@3000	8.8:1	3.15"	3.13"	97.6

VALVES

Engine & Valve	Head Diam.	Face Angle	Seat Angle	Seat Width	Stem Diameter	Stem Clearance	Valve Lift
1.6L Intake	1.654"	46°	45°	.069-.091"	.316"	.0008-.0027"
1.6L Exhaust	1.457"	46°	45°	.069-.091"	.315"	.0015-.0032"

PISTONS, PINS, RINGS

Engine	PISTONS Clearance	PINS		RINGS		
		Piston Fit	Rod Fit	Rings	End Gap	Side Clearance
1.6L	.0008-.0016"	.0002-.0004"	Press Fit	1	.012-.020"	.001-.003"
				2	.012-.020"	.002-.003"
				3	.016-.055"	Snug Fit

Ford Motor Co. 4 Engines

6-61

E
N
G
I
N
E
S

1.6 LITER 4 CYLINDER (Cont.)

CRANKSHAFT MAIN & CONNECTING ROD BEARINGS							
Engine	MAIN BEARINGS				CONNECTING ROD BEARINGS		
	Journal Diam.	Clearance	Thrust Bearing	Crankshaft End Play	Journal Diam.	Clearance	Sideplay
1.6L	2.282-2.283"	.0008-.0015"	No. 3	.004-.008"	1.885-1.886"	.0008-.0015"	.004-.011"

VALVE SPRINGS			
Engine	Free Length	PRESSURE (LBS.)	
		Valve Closed	Valve Open
1.6L	1.724"	75@1.461"	180@1.09"

CAMSHAFT			
Engine	Journal Diam.	Clearance	Lobe Lift
1.6L			
No. 1	1.761-1.762"	.0009-.0027"	.229"
No. 2	1.771-1.772"		
No. 3	1.781-1.782"		
No. 4	1.791-1.792"		
No. 5	1.801-1.802"		