

3.7 LITER 6 CYLINDER

IDENTIFICATION CODING

ENGINE IDENTIFICATION

The 8th digit of Vehicle Identification Number identifies engine cubic inch displacement and carburetor type. The VIN plate is attached to upper left side of instrument panel and visible through windshield. The VIN is also stamped, in abbreviated form, on the engine block below No. 6 spark plug hole. Cubic inch displacement also appears as second 3 digits of engine number, on a pad located below No. 1 spark plug hole.

Engine Identification		
Application	Engine No.	VIN Code
3.7L (225") 1 Bbl.	225	E

SPECIAL ENGINE MARKS

Information identifying undersize crankshaft, oversized tappets, low compression, oversized cylinder bores, engine built that day and shift are stamped at various locations on block.

M - (**M-2-3** ..) Indicate .001" undersize No. 2 & 3 Main bearing journals.

R - (**R-1-4** ..) Indicate .001" undersize No. 1 & 4 Connecting rod journals.

M-10 - Indicate .010" undersize ALL main bearing journals.

R-10 - Indicates .010" undersize all connecting rod journals. These codes are stamped on center crankshaft counterweight.

A - Indicates .020" oversize cylinder bores. Located top of front pad right side of block.

♦ - Indicates .008" oversize tappets. Located top of front pad right side of block.

O/S - Indicates .005" oversize valve stems. Located front of head on thermostat boss.

NOTE - All 225" engines have nodular cast iron crankshafts and can be identified by letters "CFD" or "AAWJ" cast into them.

ENGINE REMOVAL

See Engine Removal at end of ENGINE Section.

CYLINDER HEAD & MANIFOLDS

MANIFOLD ASSEMBLY

Removal - Disconnect all hoses and lines from air cleaner and remove air cleaner. Remove carburetor air heater and disconnect all lines and linkage to carburetor and remove carburetor. Disconnect exhaust pipe at manifold. Remove nuts and washers securing manifold assembly to cylinder head and remove manifold. Remove three screws securing intake manifold to exhaust manifold and separate manifolds.

Installation - 1) Install new gasket between intake and exhaust manifold and install three long screws securing manifold together. Do not tighten at this time. Position manifold assembly on cylinder head using a new gasket.

2) Install triangular washers and nuts on upper studs and four lower studs opposite cylinders No. 2 and 5. These eight triangular washers must be positioned squarely on machined surfaces of both intake and exhaust manifold retaining pads with cup side against manifold.

3) Install steel conical washers with cup side facing manifold, one on upper center stud and two on lower center studs. Install brass washers at each end with flat side against manifold.

NOTE - There must be at least 1/16" clearance at the minimum point between exhaust manifold and the two end brass washers.

4) Install nuts with flat side away from washers. Snug all nuts, but do not over-tighten. Tighten three intake to exhaust manifold screws, starting with inner stud. Start at center of manifold assembly and tighten all manifold nuts. Reinstall carburetor, hoses, wires, cables, linkage, air cleaner, and exhaust pipe.

CYLINDER HEAD

Removal - Drain cooling system and disconnect necessary wires, hoses and linkage. Disconnect exhaust pipe at manifold flange. Remove rocker cover, rocker arms and shaft assembly. Remove push rods and identify to insure installation in original locations. Remove cylinder head bolts, cylinder head, intake and exhaust manifold as an assembly.

NOTE - Removal of intake and exhaust manifolds is necessary only if cylinder head is to be serviced or replaced.

Installation - Coat gasket with suitable sealer. Install gasket and head on cylinder block. Install bolts and tighten in two steps to specifications. Use tightening sequence shown in Fig. 1. Install rocker arm and shaft assembly, connect all wires, hoses, cables and linkage previously removed and reverse remainder of removal procedure.

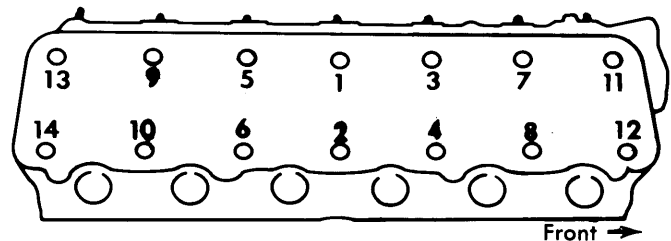

Fig. 1 Cylinder Head Tightening Sequence

VALVES

VALVE ARRANGEMENT

E-I-E-I-E-I-E-I-E-I-E

VALVE GUIDE SERVICING

Wear Check - Remove valve springs and install suitable sleeve (C-3973) over valve stem and install valve. Attach suitable dial indicator to cylinder head and set it at right angle to valve stem being measured. Total sideplay should not exceed .017". If dial reading is excessive or stems are scuffed or scored, ream guides for installation of valves with oversize stems.

Servicing - Ream guides to next oversize valve stem. Oversize valve stems are available in .005", .015" and .030" sizes.

NOTE - Do not attempt to ream guides from standard diameter to .030" oversize in one step. Use step procedure to obtain the .030".

3.7 LITER 6 CYLINDER (Cont.)

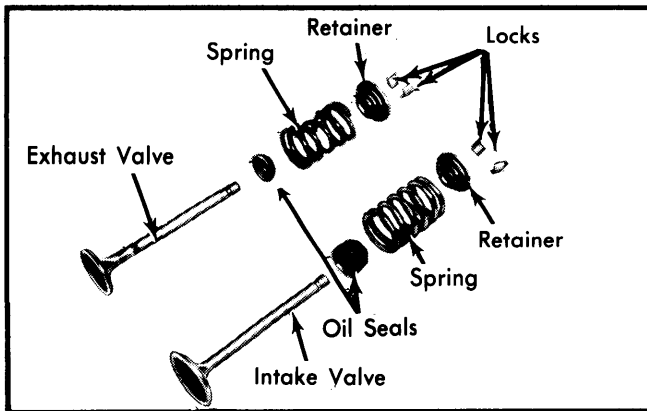

Fig. 2 Exploded View of Valve Assemblies

VALVE STEM OIL SEALS

NOTE — All valves use cup type oil seals. Intake valves use long seals and exhaust valves use shorts seals.

Removal & Installation — Remove valve springs and valve stem seals. Coat valve stems with engine oil and press new seals over valve stem squarely onto valve guide. Leave .06" gap between top of guide and seal.

VALVE SPRINGS

Removal — With cylinder head removed, compress valve springs using suitable tool (C-3422A). Remove valve retaining locks, retainers and valve springs.

Installation — Reverse removal procedure and only compress spring enough to install the locks. Check valve spring height.

VALVE SPRING INSTALLED HEIGHT

Valve springs must be square within $\frac{1}{16}$ ". Installed height of spring (measured from spring contact area on head to underside of spring retainer) should not exceed $1\frac{3}{4}$ ". If height is greater than maximum allowable, install $\frac{1}{16}$ " spacer(s) to bring height back to normal ($1\frac{3}{8}$ " to $1\frac{11}{16}$ ").

ROCKER ARM ASSEMBLY

See Fig. 3 for assembly of parts, noting the following: The assembly must be installed with oil hole upward and toward

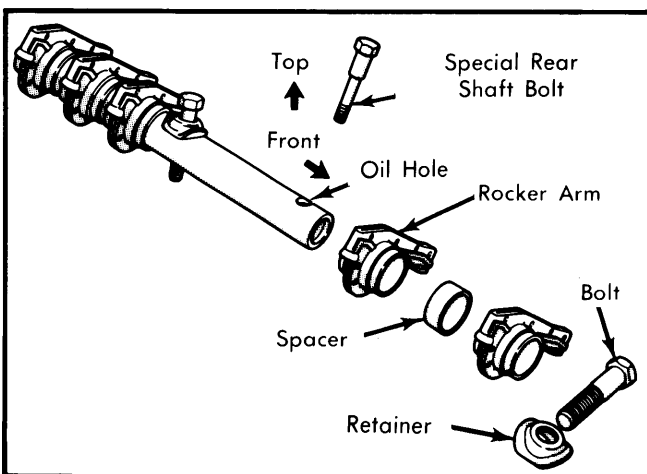

Fig. 3 Partially Disassembled View of Rocker Arm Shaft Assembly

front of engine. Be sure that shaft retainers are seated on rocker arm shaft and not on extended bushing or rocker arm. Install long retainer at center position and special shaft bolt at rear of engine. See Figs. 3 and 8. Tighten bolts.

HYDRAULIC VALVE LIFTER ASSEMBLY

NOTE — Lifters are serviced as complete assemblies only. Parts are not interchangeable between lifters. If any component of lifter is worn or damaged, complete lifter must be replaced.

To test, remove cap from plunger. Fill plunger body with clean kerosene and install plunger. Unseat check ball and replace cap. Place lifter upright in suitable lifter testing tool (C-4343) and check leakdown. If lifter collapses immediately, disassemble, clean and retest. If rapid leakdown still occurs, replace lifter.

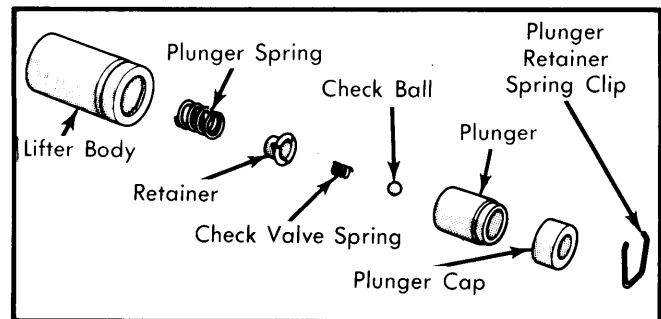

Fig. 4 Exploded View of Hydraulic Lifter Assembly

PISTONS, PINS & RINGS

OIL PAN

See Oil Pan Removal at end of ENGINE Section.

PISTON & ROD ASSEMBLY

Removal — 1) With cylinder head and oil pan removed, use a suitable ridge reamer (C-3012) to remove any ridge or deposits on upper end of cylinder bore.

NOTE — Piston must be at bottom of stroke and covered with cloth to collect cuttings.

2) Inspect connecting rods and caps for cylinder identification and mark as necessary. Remove rod cap and push piston and rod assembly out top of cylinder block. Use care not to nick crankshaft journal or cylinder wall. Install rod caps on mating rods.

Installation — 1) Compression ring gaps must be located on piston so they will be on left side of engine and staggered about 60° apart.

NOTE — Neither gap should line up with oil ring rail gaps.

2) Rotate oil ring expander so gaps are at right side of engine and rotate steel rails so gaps are opposite (positioned above piston pin holes).

3) Lightly coat cylinder bores, pistons and rings with engine oil, slide suitable ring compressor (C-385) over piston and tighten. Install each piston and rod assembly (notch on piston head and oil hole in rod facing front of engine) in its respective bore and guide connecting rod onto crankshaft journal. Tap

3.7 LITER 6 CYLINDER (Cont.)

piston head with hammer handle to seat connecting rod against crankshaft. Install rod caps, nuts and tighten.

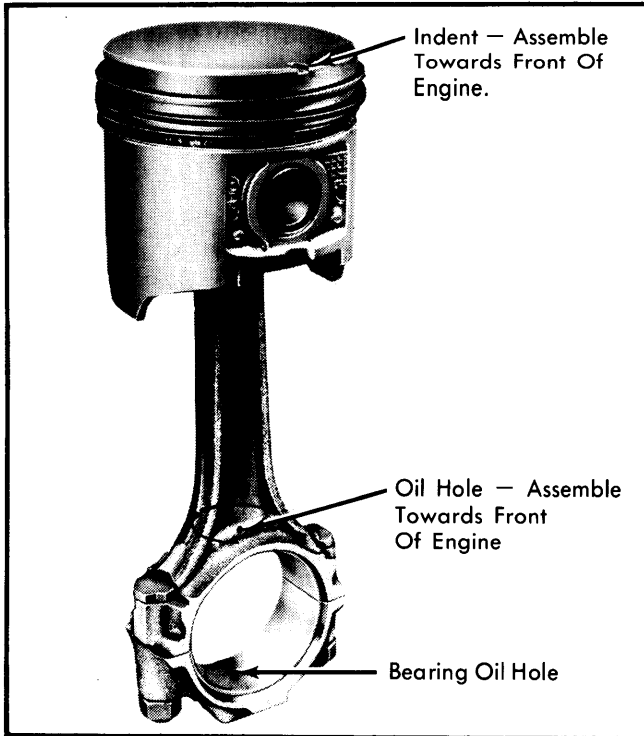

Fig. 5 Assembling Piston to Connecting Rod

FITTING PISTONS

With pistons and cylinder bores dry and clean, measure for piston-to-cylinder wall clearance (.0005-.0015"). Measurements should be taken at room temperature (70° F). Measure piston diameter at top of skirt 90° to piston pin axis. Measure cylinder bore halfway down cylinder and 90° to crankshaft center line.

PISTON PINS

Removal — Use tool layout shown in Fig. 6 to press piston pin from bore.

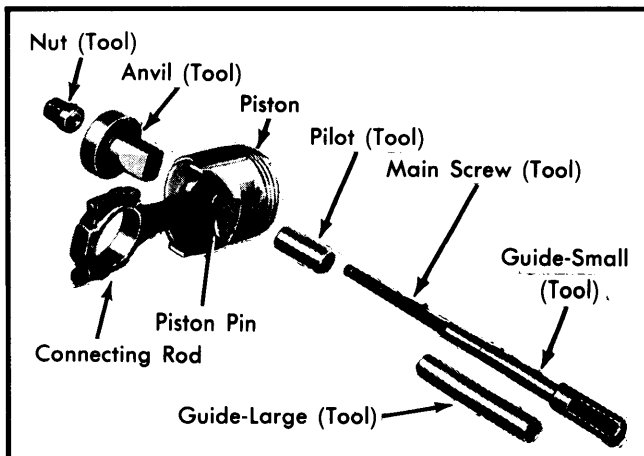

Fig. 6 Tool Arrangement for Piston Pin Removal

Installation — Lubricate pin bore and use suitable tool (C-3724) and arbor press to install piston pin while noting following: Position piston head and connecting rod with notch and oil hole UP so oil hole will face front of engine upon installation. Press pin into position until pin bottoms on pilot tool.

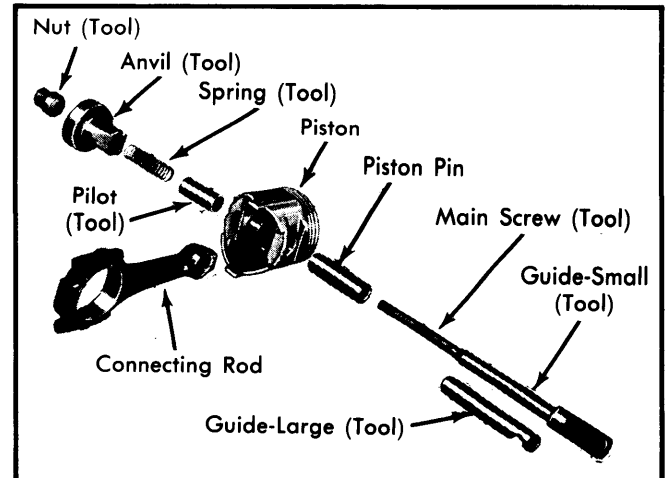

Fig. 7 Tool Arrangement for Installing Piston Pin

CRANKSHAFT & ROD BEARINGS

MAIN & CONNECTING ROD BEARINGS

Connecting Rod Bearings — 1) After ensuring rod caps are properly identified for later installation on same rods, remove rod caps. If shim stock method is used, smooth edges of a 1/2" by 3/4" piece of brass shim stock .001" thick. Oil and place between bearing and connecting rod journal. Install bearing cap and tighten.

2) Rotate crankshaft 1/4 turn in each direction. If a slight drag is felt, clearance is within limits. If no drag is felt, clearance is excessive. If crankshaft can not be rotated, clearance is not enough.

3) Using Plastigage method, insert a .001" to .003" (Green) piece of Plastigage between bearing and connecting rod journal. Install bearing cap and tighten to correct torque specification.

4) Remove bearing cap and compare width of Plastigage with scale on package. If Plastigage width is within specifications, move on to next rod bearing. If it is not, fit rod with correct undersized bearings.

5) New bearings are available in standard, .001", .002", .003", .010" and .012" undersize. Always install bearings in pairs. Do not use a new bearing with an old bearing. Install connecting rod bearings so formed tang fits into machined groove in connecting rod. Install rod caps and tighten nuts.

Main Bearings — 1) Using either Shim Stock method or Plastigage method, check main bearing clearances one at a time while all other main bearing caps are tight. New bearings are available in standard, .001", .002", .003", .010" and .012" undersize. A new .001" bearing half may be used in combination with a new standard bearing half or a .002" with a .001" bearing.

NOTE — Always use smaller diameter bearing half as upper bearing.

3.7 LITER 6 CYLINDER (Cont.)

2) If bearing clearances are not within limits, remove bearing cap, insert suitable tool (C-3509) in oil hole journal and rotate crankshaft clockwise to remove upper bearing half. To install new upper bearing, lightly chamfer sharp edges from plain side and start bearing in place.

3) Insert tool and slowly rotate crankshaft counterclockwise, sliding bearing in place. Install main bearing cap with new bearing installed and tighten.

NOTE — Upper main bearings are grooved and lower main bearings are plain. Upper and lower are not interchangeable.

4) Check crankshaft end play and if it is not within the correct specifications, change number three main bearing. This bearing carries thrust load. Recheck crankshaft end play.

REAR MAIN BEARING OIL SEAL

New split type rubber seals may be replaced without removing the crankshaft. New type seals must be installed as a pair and cannot be used or combined with old type rope seals.

Removal — Remove oil pan, rear seal retainer, and rear main bearing cap. Remove lower seal by carefully prying from the side with small screwdriver. Remove upper rope seal by turning suitable tool (C-4148) into end of seal and pulling seal out with tool. Use care not to mar crankshaft, rotating the shaft as seal is pulled out.

Installation — 1) Oil upper seal lip lightly with engine oil. Hold seal (with paint stripe to rear) tightly against crankshaft with your thumb. Rotate crankshaft while sliding seal into groove.

CAUTION — Sharp edge of groove in block may shave or nick back of the seal. Use care not to damage the sealing lip.

2) Install lower half of seal into lower seal retainer with paint stripe to rear. Install main bearing cap and tighten. Install lower seal retainer and tighten.

NOTE — Do not use sealer or cement on seal ends or on lip.

CAMSHAFT

ENGINE FRONT COVER

Removal — Drain cooling system and remove radiator and fan. Use suitable puller (C-3732A) and remove vibration damper. Loosen oil pan bolts to provide clearance between pan and lower flange of cover. Remove cover bolts and cover.

Installation — Check that mating surfaces of chain case cover and cylinder block are clean and free from burrs. Install cover with new gasket and tighten bolts. Tighten oil pan bolts with gaskets in place. Install vibration damper, radiator and fan. Fill cooling system.

FRONT COVER OIL SEAL

Removal — Disconnect battery, drain cooling system and remove radiator and fan assembly. Remove power steering crankshaft pulley and vibration damper. Use a suitable tool to pry behind lip of oil seal, being careful not to damage crankshaft seal surface of cover.

Installation — Install new seal by installing the threaded shaft part of tool (C-4251) into threads of crankshaft. Place

seal into opening with seal spring towards the inside of engine. Place installing adapter (C-4251-2) with the thrust bearing and nut on the shaft. Tighten nut until tool is flush with the timing chain cover. Reverse removal procedure.

TIMING CHAIN

Checking For Stretch — Place scale next to timing chain to measure any movement of the chain. Place torque wrench with socket over camshaft sprocket lock bolt and apply torque in direction of crankshaft rotation to take up slack. Torque should be 30 ft. lbs. with head installed or 15 ft. lbs. with head removed. Do not permit crankshaft to move as you apply torque in reverse direction. Measure amount of chain movement and replace timing chain if in excess of $\frac{1}{8}$ " movement.

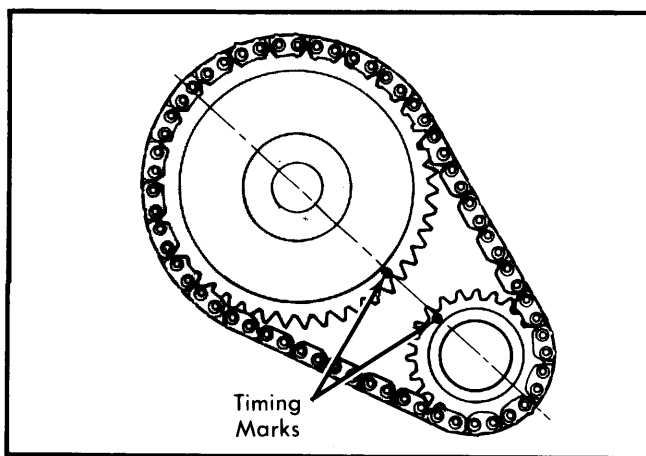

Fig. 8 Timing Chain and Crankshaft Sprocket Alignment

Removal & Installation — Remove camshaft sprocket attaching bolt and remove timing chain with camshaft sprocket. Turn crankshaft to line up centerline of camshaft and crankshaft with the timing mark on crankshaft sprocket. Install camshaft sprocket and timing chain. Line up timing marks on sprockets with centerline of crankshaft and camshaft. Tighten camshaft sprocket bolt.

CAMSHAFT

Removal — Remove lifters, using suitable tool (C-4129). Keep in order for later installation in original locations. Remove timing chain sprockets, distributor, oil pump and fuel pump. Install a long bolt in front end of camshaft to facilitate careful removal. Remove camshaft, being careful not to damage cam bearings with cam lobes.

Installation — If camshaft is being replaced, check tappet faces for "dished" wear and replace if necessary. Lubricate camshaft lobes and bearing journals. Carefully install camshaft in cylinder block. Install all components removed prior to camshaft removal.

CAMSHAFT BEARINGS

Removal — With camshaft removed, drive out rear cam bearing welch plug. Install proper size adaptors and horseshoe washers (C-3132A) at the back of each bearing and drive out all bearings.

Installation — 1) Install new bearings using suitable tool (C-3132A) to slide new bearing over the proper adaptor. Position

3.7 LITER 6 CYLINDER (Cont.)

bearing on tool. Install horseshoe lock and drive the bearing into place.

NOTE — Camshaft bearing oil hole or holes must be in exact alignment with drilled oil passages from main bearings.

2) Install No. 1 camshaft bearing $\frac{3}{32}$ " inward from front face of cylinder block. Apply sealer to new cam plug and install at rear of camshaft. Be sure this plug does not leak.

VALVE TIMING

1) Turn crankshaft until No. 6 exhaust valve is closing and No. 6 intake is opening.

2) Insert a $\frac{1}{4}$ " spacer between arm pad and stem tip of No. 1 intake valve. Allow spring load to bleed tappet down. Install dial indicator so plunger contacts valve spring retainer as nearly perpendicular as possible. Zero indicator.

3) Rotate the crankshaft clockwise until the valve has lifted .010". Timing mark should read from 12° before top dead center to 0° before top dead center. Remove spacer.

4) If front pulley marks are not within limits, inspect sprocket; index marks, timing chain for wear or check accuracy of TDC mark on front pulley.

ENGINE OILING

Crankcase Capacity — 5 quarts. Add 1 quart with filter change.

Oil Filter — Replace every second oil change. Follow installation directions printed on case of new filter.

Normal Oil Pressure — 30-70 psi at 2000 RPM.

Pressure Regulator Valve — In oil pump body. Not adjustable.

ENGINE OILING SYSTEM

Refer to Fig. 9 and note the following:

Rocker Arms & Valves — Transverse channel in rear camshaft journal feeds oil from rear camshaft bearing up along right rear cylinder head bolt and into the rocker shaft at rear attaching bolt. Oil then passes through rocker arm and down hollow push rod to lifter.

Crankshaft Bearings — All main bearings are lubricated as shown in Fig. 9. Connecting rod bearings are lubricated by holes drilled in crankshaft between main and rod journals.

OIL PUMP

Disassembly — Remove pump cover and seal ring. Press off drive gear while supporting gear to eliminate load on aluminum body of pump. Remove outer rotor and inner rotor with shaft. Remove oil pressure relief valve plug, spring and valve.

Inspection — Clean and inspect all parts for damage. Measure all clearances indicated in Oil Pump Specifications table and replace as follows:

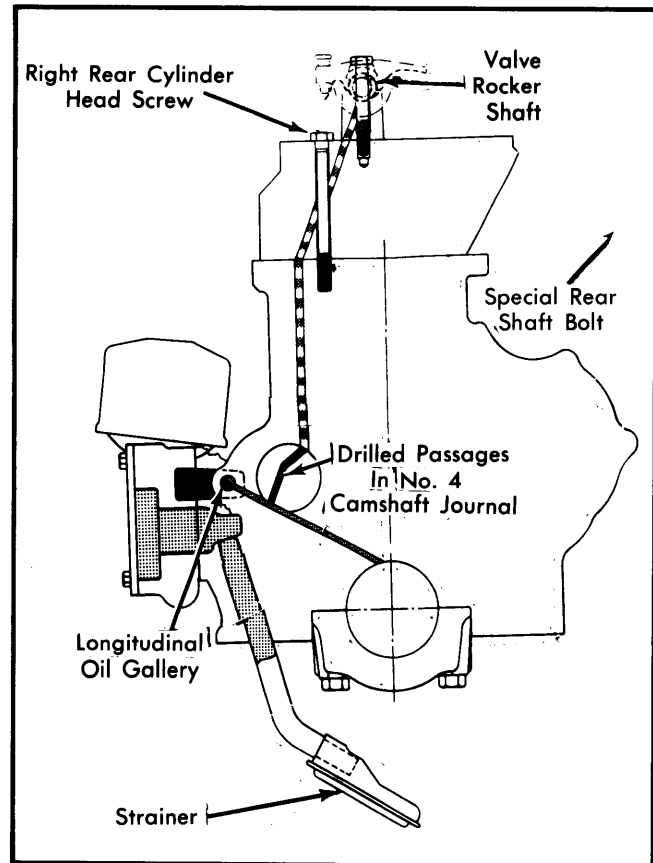

Fig. 9 Diagram of Engine Oiling Circuit

1) Replace entire pump assembly if pump cover wear, clearance over rotors or outer rotor-to-pump body clearance are not within specifications.

2) Replace both rotor assemblies if tip clearance between rotors, rotor thickness or rotor diameter are not within specifications.

3) Oil pressure relief valve must be free from scoring and operate freely in bore of pump body. Spring should have a free length of $2\frac{1}{4}$ " and test between 22.3 and 23.3 lbs. when compressed to $1\frac{1}{32}$ ". Replace spring which does not meet specifications.

Assembly & Installation — Assemble pump in reverse order of disassembly using new parts as necessary. Prime oil pump before installation by filling rotor cavity with engine oil. Install pump on engine.

Oil Pump Specifications

Application	Specification
Pump Cover Wear0015" Max.
Inner & Outer Rotor Thickness825" Min.
Outer Rotor Diameter	2.469" Min.
Clearance Over Rotors004" Max.
Outer Rotor-to-Pump Body Clearance014" Max.
Tip Clearance Between Rotors010" Max.

3.7 LITER 6 CYLINDER (Cont.)

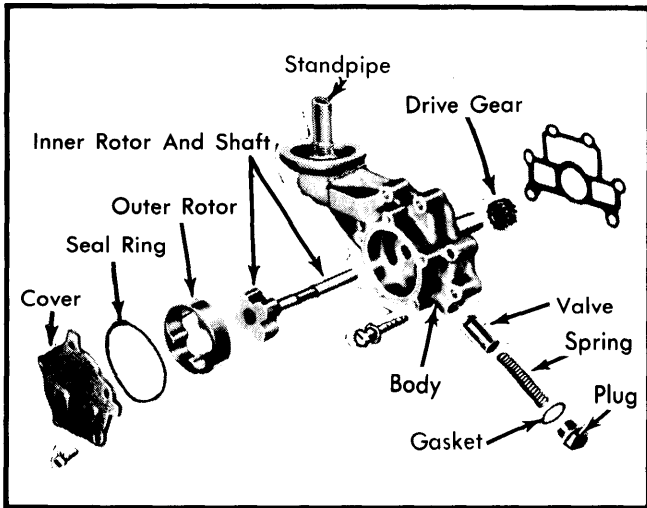

Fig. 10 Exploded View of Oil Pump Assembly

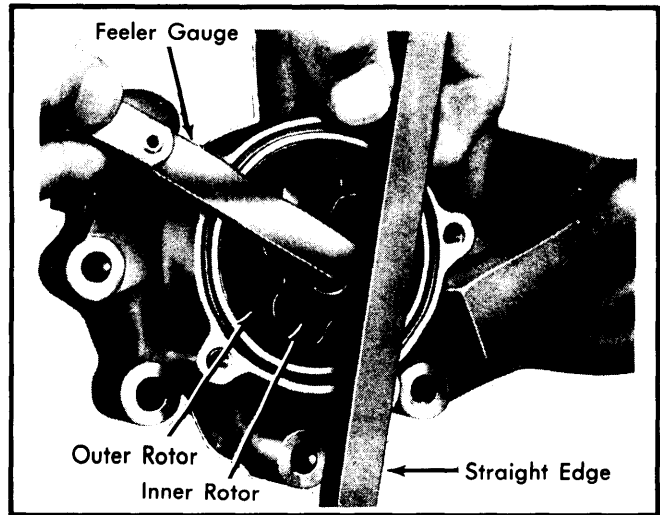

Fig. 11 Making Rotor Clearance Measurement with Feeler Gauge and Straightedge

ENGINE SPECIFICATIONS

GENERAL SPECIFICATIONS						
Engine	Net HP at RPM	Torque (Ft. Lbs. at RPM)	Compr. Ratio	Bore	Stroke	Displ. Cu. Ins.
225" 1-Bbl.	85 @ 3600	165 @ 1600	8.4:1	3.40"	4.12"	225

VALVES							
Engine & Valve	Head Diam.	Face Angle	Seat Angle	Seat Width	Stem Diameter	Stem Clearance	Valve Lift
225" Int.	1.615-1.625"	45°	45°	.070-.090	.372-.373	.001-.003	.378
Exh.	1.355-1.365"	43°	45°	.040-.060	.371-.372	.002-.004	.378

VALVE SPRINGS			
Engine	Free Length	PRESSURE (LBS.)	
		Valve Closed	Valve Open
225"	1.92"	49-57 @ 1 1/16"	137-150 @ 1 3/16"

VALVE TIMING				
Engine	INTAKE		EXHAUST	
	Open (BTDC)	Close (ABDC)	Open (BBDC)	Close (ATDC)
225"	6°	42°	36°	12°

PISTONS, PINS, RINGS						
Engine	PISTONS Clearance	PINS		RINGS		
		Piston Fit	Rod Fit	Rings	End Gap	Side Clearance
225"	.0005-.0015"	.00035-.00085"	⓪.0007-.0017"	1	.010-.020"	.0015-.003"
				2	.010-.020"	.0015-.003"
				3	.015-.055"	.0002-.005"

⓪ — Interference fit.

Chrysler Corp. 6 Engines

3.7 LITER 6 CYLINDER (Cont.)

ENGINE SPECIFICATIONS (Cont.)

CRANKSHAFT MAIN & CONNECTING ROD BEARINGS							
Engine	MAIN BEARINGS				CONNECTING ROD BEARINGS		
	Journal Diam.	Clearance	Thrust Bearing	Crankshaft End Play	Journal Diam.	Clearance	Side Play
225"	2.7495-2.7505"	.0010-.0025"	No. 3	.0035-.0095"	2.1865-2.1875"	.0010-.0025"	.007-.013"

CAMSHAFT			
Engine	Journal Diam.	Clearance	Lobe Lift
225"			
No.1	1.998-1.999"	.001-.003"
No.2	1.982-1.983"		
No.3	1.967-1.968"		
No.4	1.951-1.952"		

TIGHTENING SPECIFICATIONS

Application	Ft. Lbs.
Cylinder Head	70
Manifold-to-Cylinder Head	10
Intake-to-Exhaust Manifold	① 17
Oil Pan	17
Main Bearing Cap	85
Rear Main Bearing Seal Retainer	30
Connecting Rod Cap	45
Camshaft Sprocket	50
Rocker Shaft Support Bracket	24
Rocker Arm Cover	3
Oil Pump Cover	8
Engine Front Cover	17
Oil Pump Attaching Bolt	17
Water Pump	30
Oil Filter Stud	10
Front Mount-to-Frame	75
Front Mount-to-Engine	65

① — Tighten $\frac{3}{8}$ " bolt to 20 ft. lbs.