

2.6L 4 CYLINDER

Chrysler Corp.
Aries
Reliant

ENGINE CODING

ENGINE IDENTIFICATION

Engine model code and serial number are stamped on engine block just below No. 1 spark plug on right side of block, near exhaust manifold stud (dash panel side of vehicle). The engine identification number is located between the core plug and rear face of block (radiator side of engine).

Engine Code	
Engine	Code
2.6L (156")	D①
① — 7th position of Vehicle Identification Number.	

ENGINE REMOVAL

See *Engine Removal* at end of ENGINE Section.

CYLINDER HEAD & MANIFOLDS

CYLINDER HEAD & INTAKE MANIFOLD

Removal — 1) Drain cooling system and disconnect upper radiator hose. Remove breather hoses and purge hose. Remove air cleaner and fuel line. Remove vacuum hose at distributor. Disconnect spark plug cables and remove distributor.

2) Disconnect heater hose at intake manifold. Disconnect water temperature gauge unit wire. Remove fuel pump. Disconnect exhaust pipe at exhaust manifold flange. Remove exhaust manifold. Remove intake manifold and carburetor as an assembly.

3) Remove cylinder head cover, breather and semi-circular packing. Turn crankshaft until No. 1 piston is at TDC of compression stroke. Using white paint, scribe mating marks on timing chain in line with timing mark on camshaft sprocket if links are not plated. Remove camshaft sprocket bolt and distributor drive gear. Remove camshaft sprocket. Remove cylinder head bolts in sequence shown in Fig. 1. Loosen bolts in 3 stages to prevent cylinder head warpage.

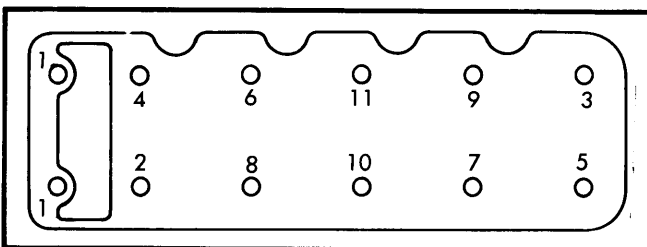

Fig. 1 Cylinder Head Bolt Removal Sequence
(Install in Reverse Order)

4) Cylinder head assembly must be carefully lifted off 2 dowels on cylinder block. Do not slide assembly or twist sprocket and chain. Remove cylinder head assembly and head gasket.

Installation — 1) Clean all gasket surfaces of cylinder block and cylinder head. Install new cylinder head gasket, using no sealant. Do not reuse head gaskets. Install cylinder head assembly and tighten cylinder head bolts in reverse order of that shown in Fig. 1. Beginning with highest number first, tighten bolts in sequence in 2 stages, first to 35 ft. lbs. and then to 69 ft. lbs.

NOTE — Avoid sliding cylinder head when installing in order to prevent damage to gasket and aligning dowels (when installed). Engine should not be run with cylinder head cover off due to oil spray from rocker arms.

2) Reverse remainder of removal procedure, noting the following: Install the breather and semi-circular packing to cylinder head and apply sealant to points shown in Fig. 2.

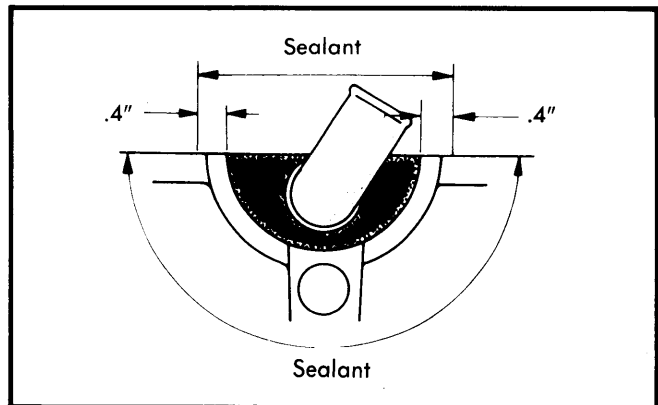

Fig. 2 Sealant Application Points

3) Temporarily set valve clearance to cold engine settings; then readjust to hot engine settings after engine is at normal operating temperature. Install cylinder head cover. Install new intake manifold gasket, using appropriate sealer on each side of gasket around water holes. Install air cleaner and breather hoses.

VALVES

VALVE ARRANGEMENT

Intake — Left side.

Exhaust — Right side.

Jet Valve — Left side.

JET VALVES

1) Using special jet valve socket wrench (MD998310), remove jet valves. Disassemble valve, using snap ring pliers (MD998309) to compress spring and remove retainer lock. Check valve head and seat for damage, and make sure jet valve slides smoothly in body without play.

CAUTION — Make certain that jet valve socket wrench is not tilted with respect to center of valve. If tool is tilted, stem may be bent, resulting in defective valve operation and a broken wrench. Do not disturb jet valve and body combinations. If defective, jet valve and body should be replaced as an assembly.

2.6L 4 CYLINDER (Cont.)

2) When assembling, lubricate parts with engine oil. See Fig. 3. Compress spring and install retainer and lock. Install new "O" ring, lubricated with engine oil, on jet valve body. Install valve stem seal, using seal driver (MD998308).

VALVE SPRINGS

With camshaft and rocker arm assembly removed, use valve lifter and remove retainer locks (keepers). See Fig. 3. Remove all retainers, springs, spring seats and valves, keeping them in proper order for reassembly. Check valve spring free length and pressure. Standard squareness should be 1.5° or less. If beyond 3°, replace spring. Installed height of a new intake or exhaust valve spring should be 1.590". If 1.629" or more, replace spring.

VALVE GUIDE SERVICING

1) Check valve stem-to-guide clearance, and if clearance exceeds service limits, replace valve guide with next oversize component. Guides are available in the following oversizes:

Valve Guide Oversizes		
Size Mark	Guide Size	Cyl. Head Bore
5002"	.5138-.5145"
25010"	.5216-.5224"
50020"	.5315-.5323"

2) Heat cylinder head to approximately 480° F, and using a suitable valve guide tool, drive out each guide toward combustion chamber. Ream guide bore in cylinder head to specified size after head has cooled to room temperature.

3) To install new guides, reheat head to same temperature as for removal. Quickly insert and drive guides into head. See Fig. 4. Guides should protrude .539-.563" above head surface when properly installed. Check guide I.D. and ream as necessary.

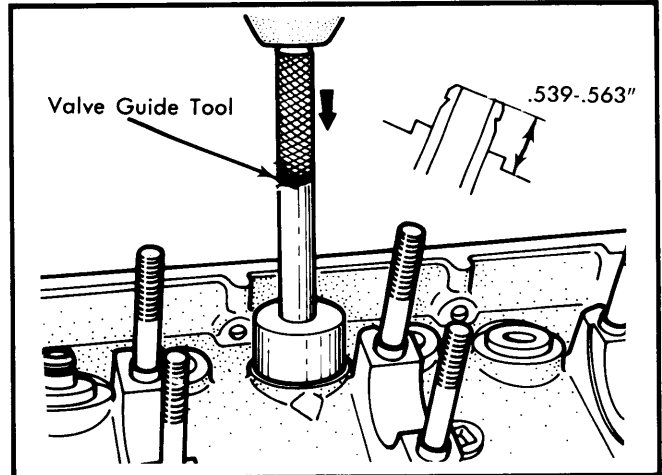

Fig. 4 Valve Guide Installation and Height

VALVE STEM OIL SEALS

Cylinder head must be removed from engine. After installing valve spring seat, place stem seal on guide. See Fig. 5. Use installer to lightly hammer seal into correct position as tool bottoms on head. Do NOT use old seals and do NOT twist seals when installing.

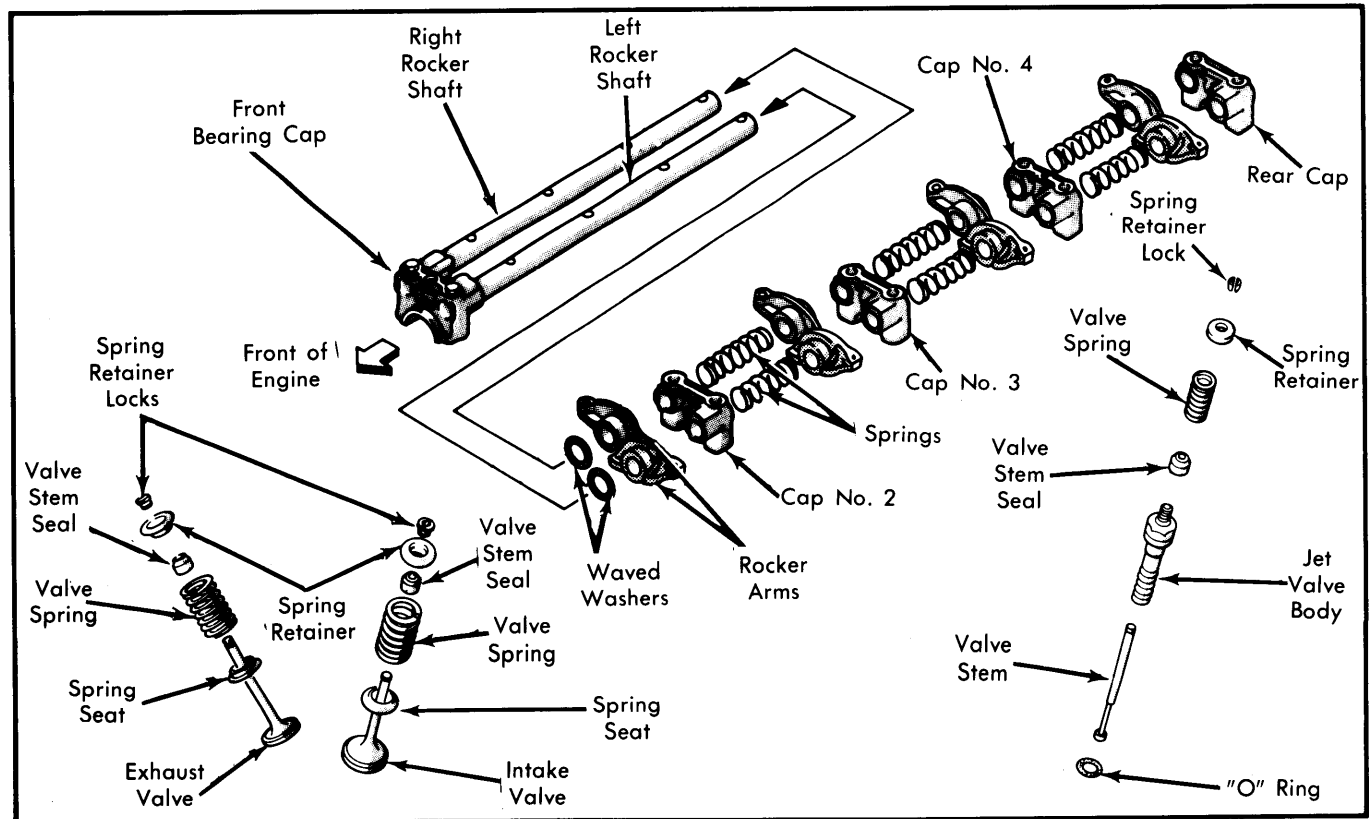

Fig. 3 Rocker Arm and Valve Assembly

2.6L 4 CYLINDER (Cont.)

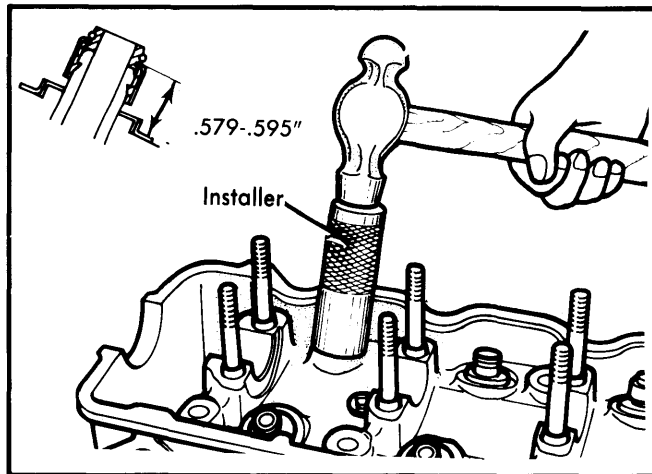

Fig. 5 Valve Stem Oil Seal Installation and Height

VALVE SEAT SERVICING

- 1) Check valve seat for damage or wear. Replace or rework seat, as necessary. If reworking seat, check valve guide first. Make proper replacement, if required, then check seat for necessary corrections.
- 2) Recondition valve seat with suitable grinder or cutter to specified contact width. After rework, valve and seat should be lapped with suitable compound.
- 3) Valve seat sink (wear of seat inward allowing valve to seat too deep in head) must be checked by measuring installed height of valve spring. Measure between spring seat and retainer with all spring components installed. See *Valve Springs*.
- 4) Remove valve seat by thinning down with a suitable cutter. Then machine seat bore to proper size for replacement seat. Heat head to approximately 480° F, and press in oversize seat. Replacement seats are available in .012" and .024" oversizes, marked "30" and "60", respectively.

VALVE CLEARANCE ADJUSTMENT

NOTE — Adjust jet valve clearance before adjusting intake valve clearance. Incorrect jet valve clearance can affect emission levels and could cause engine problems.

Jet Valve — 1) Cylinder head bolts should be retightened before starting adjustment. Warm engine until coolant temperature reaches 176-194°F. Position piston in cylinder at TDC of compression stroke. Back off intake valve adjusting screw 2 or more turns.

- 2) Loosen lock nut on jet valve adjusting screw. Turn screw counterclockwise and insert a .006" leaf-type feeler gauge between jet valve stem and adjusting screw.
- 3) Tighten adjusting screw until it touches feeler gauge. Do not press in valve, as spring tension is very weak. Use special care when it becomes difficult to turn adjusting screw.
- 4) Tighten lock nut securely, while holding rocker arm adjusting screw with a screwdriver to prevent it from turning. Be

sure .006" feeler gauge is easily inserted. Adjust intake valve clearance and check for idle CO, HC and RPM settings.

Intake and Exhaust Valves — 1) Be sure engine is warm (coolant temperature 176-194° F). Position piston at TDC of compression stroke. Loosen lock nut.

2) Adjust valve clearance by turning adjusting screw while measuring clearance with a feeler gauge. Hot engine settings are .006" for intake valves, .010" for exhaust valves.

PISTONS, PINS & RINGS

OIL PAN

See *Oil Pan Removal* at end of *ENGINE* Section.

PISTON & CONNECTING ROD ASSEMBLY

Removal — Remove cylinder head and oil pan. Check to be sure connecting rods and rod caps are marked to aid in assembling components to their original locations. Remove carbon ridge from cylinder bores. Remove connecting rod caps and bearings, and push connecting rod and piston assembly upward through top of cylinder block.

Installation — 1) Lubricate all internal surfaces with engine oil before installing. Make sure arrows on tops of pistons point toward timing chain. Match marks on connecting rods and caps should align and should be on right side of engine.

2) Use a ring compressor to compress rings (without changing ring position on piston). Install piston and connecting rod assembly into cylinder block in original cylinder location. Tap lightly on piston dome with wooden tool handle, while guiding connecting rod onto crankshaft. Install rod cap onto proper piston and connecting rod assembly. Tighten attaching bolts. Install cylinder head and oil pan.

FITTING PISTONS

1) After checking block for distortion, cracks, scratches or other abnormalities, measure cylinder bores at 3 levels. Top and bottom levels should be .38" from end of cylinder. If any distortion exceeds .001" from standard bore size, block must be rebored and oversize piston installed. Standard bore size is 3.5866".

NOTE — Pistons are available in standard, .010", .020", .030" and .039" oversizes. Oversize pistons are stamped on crown to indicate amount of oversize.

2) Check outside diameter of piston by measuring at a point .079" from bottom of skirt and at 90° to pin bore. Determine amount of cylinder reboring required to meet specified clearance.

PISTON PINS

Check piston pin-to-bore fit. Lubricate pin and small end of bore with engine oil. Set connecting rod and piston with arrow facing up and connecting rod marks properly located. Using guide bar and push rod, press piston pin into bore, using 1,654-3,859 lbs. force at normal temperature.

2.6L 4 CYLINDER (Cont.)

NOTE — When removing or installing piston pin, connecting rod should be in firm contact with body of pin setting tool.

PISTON RINGS

1) Measure piston ring side and end clearance for all pistons, and replace rings as necessary. When replacing a ring without correcting the cylinder bore, check ring end gap at least .63" from bottom of bore. When replacing a ring, be sure to use one of same size.

2) Install rings on pistons with end gaps staggered at 120° intervals, but make sure no ring gap is in line with thrust face of pin bore. See Fig. 6. Also be sure the manufacturer's marks are facing upward when rings are installed.

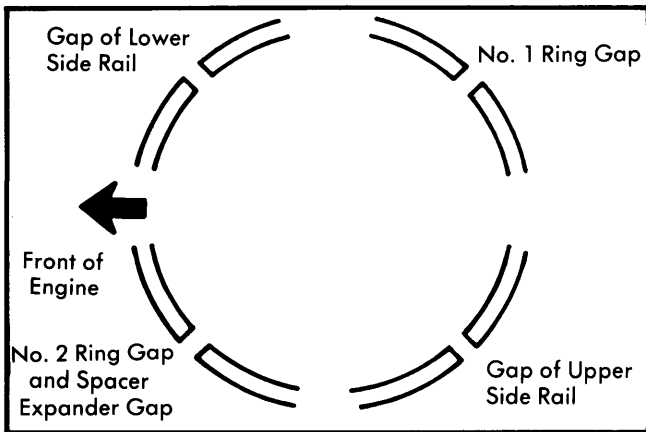

Fig. 6 Piston Ring Gap Positions

3) Install oil ring expander first, followed by upper oil ring side rail and lower side rail. When installing side rail, place one end between piston ring groove and expander. Hold this end firmly and press down portion to be installed until side rail is in position. Do not use a ring expander on side rails. Then install intermediate piston ring and upper piston ring.

NOTE — Upper and intermediate (No. 1 and No. 2) piston rings have the same thickness, but different shapes. Oil ring expander gap should be at least 45° from side rail gaps, but not on piston pin center or on thrust direction.

4) Piston rings are available in standard size, .010", .020", .030" and .039" oversizes. Standard rings have no marking, but oversize rings are marked "25", "50", "75" and "100", respectively.

CRANKSHAFT & ROD BEARINGS

MAIN & CONNECTING ROD BEARINGS

NOTE — The following procedures are performed with oil pan and oil pump removed.

1) Inspect each bearing for peeling, melting, seizure or improper contact. Replace defective bearings. Measure outside diameter of crankshaft and connecting rod journals to determine if out-of-round or tapered. No. 1 bearing is at timing chain end.

2) Cut Plastigage to same length as width of bearing. Place it parallel with journal (not over oil holes). Install crankshaft

bearings and caps, tightening to specifications. Always install caps with arrow facing toward timing chain.

NOTE — When using Plastigage to check main bearings, remove weight from crankshaft by supporting counterweight with a jack or preferably by shimming adjacent bearings. To check connecting rod clearances, crankshaft does not have to be supported, but before checking, turn crankshaft until connecting rod to be checked starts moving toward top of engine. Only then should cap be assembled and torqued to specifications. Do not turn crankshaft with Plastigage installed.

3) Remove main bearing cap from crankshaft and measure Plastigage at its widest part (using scale on Plastigage package). Repeat procedure for connecting rod bearings. If clearance exceeds limits, replace bearing. Undersize bearings are available in .010", .020", and .030" undersizes.

Crankshaft Main Bearing Journals^①

Size	Diameter
Standard	2.3616-2.3622"
1st Undersize	2.3518-2.3524"
2nd Undersize	2.3419-2.3425"
3rd Undersize	2.3321-2.3327"

^① — Maximum out-of-round is .0004".

Connecting Rod Journals^①

Size	Diameter
Standard	2.0860-2.0866"
1st Undersize	2.0762-2.0767"
2nd Undersize	2.0663-2.0669"
3rd Undersize	2.0565-2.0571"

^① — Maximum out-of-round is .0004".

THRUST BEARING

With crankshaft bearing caps installed, check thrust clearance (end play) by inserting feeler gauge between center main bearing and crankshaft thrust face. If clearance exceeds .002-.007", replace center main bearing.

FRONT & REAR OIL SEALS

REAR OIL SEAL

Remove screws holding crankshaft rear oil seal case, and remove case. Remove separator from case, and remove oil seal. Install new seal into case, and install separator, making sure hole is located at bottom of separator. Install case.

FRONT OIL SEAL

Remove crankshaft drive pulley. Pry out oil seal, using care not to nick or damage sealing surfaces. Install new oil seal, coating it lightly with Loctite Stud N' Bearing Mount (PN4057987) or equivalent. Install crankshaft drive pulley.

2.6L 4 CYLINDER (Cont.)

CAMSHAFT TIMING CHAIN
& SILENT SHAFTS

CAMSHAFT

Removal — 1) Remove breather hoses and purge hose. Remove air cleaner and fuel line. Remove fuel pump. Disconnect spark plug cables. Remove cylinder head cover and breather. Remove semi-circular packing.

2) Loosen camshaft sprocket bolt slightly, and turn crankshaft until No. 1 piston is at TDC on compression stroke. Remove camshaft sprocket bolt and distributor drive gear. See Fig. 7.

3) Remove camshaft sprocket with timing chain and place on sprocket holder. Remove camshaft bearing cap tightening bolts.

NOTE — It is recommended that front and rear bearing cap bolts not be removed, but be kept inserted in bearing caps. In this way, rocker shaft assembly can be removed without parts being disassembled or falling off shafts.

4) Remove rocker arms, rocker shafts and bearing caps as an assembly. Remove camshaft.

Installation — 1) Check camshaft journals for wear, scratches or seizure. Check lobes for damage and each bearing for wear. If bearing surfaces are excessively worn, scratched or binding, replace cylinder head assembly.

2) Lubricate camshaft lobes and bearing journals. Install camshaft to cylinder head. Install assembled rocker arm shaft

assembly. Position camshaft so dowel pin on front end is positioned as shown in Fig. 8 (viewed from the front).

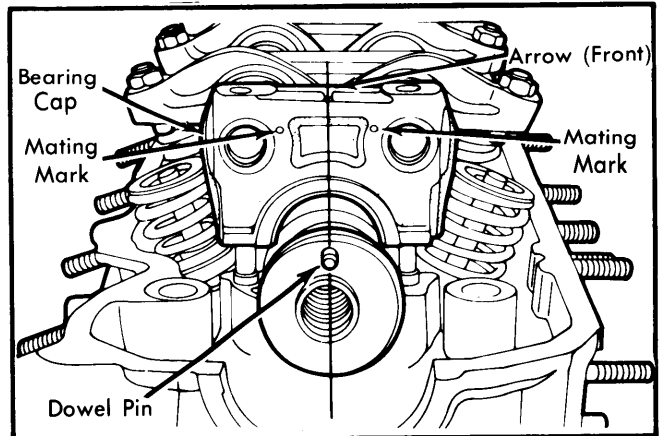

Fig. 8 Camshaft Installation Position and Bearing Cap-Rocker Arm Shaft Mating Marks

3) Install camshaft bearing cap tightening bolts. Starting at center, tighten all bolts to 7 ft. lbs. in sequence of center, No. 2, No. 4, front and rear caps. Repeat sequence, tightening to 14-15 ft. lbs.

4) Install camshaft sprocket and distributor drive gear onto camshaft. Tighten locking bolt temporarily. Back off crankshaft about 90°. Tighten camshaft sprocket locking bolt to specification. Set valve clearance temporarily to cold engine setting.

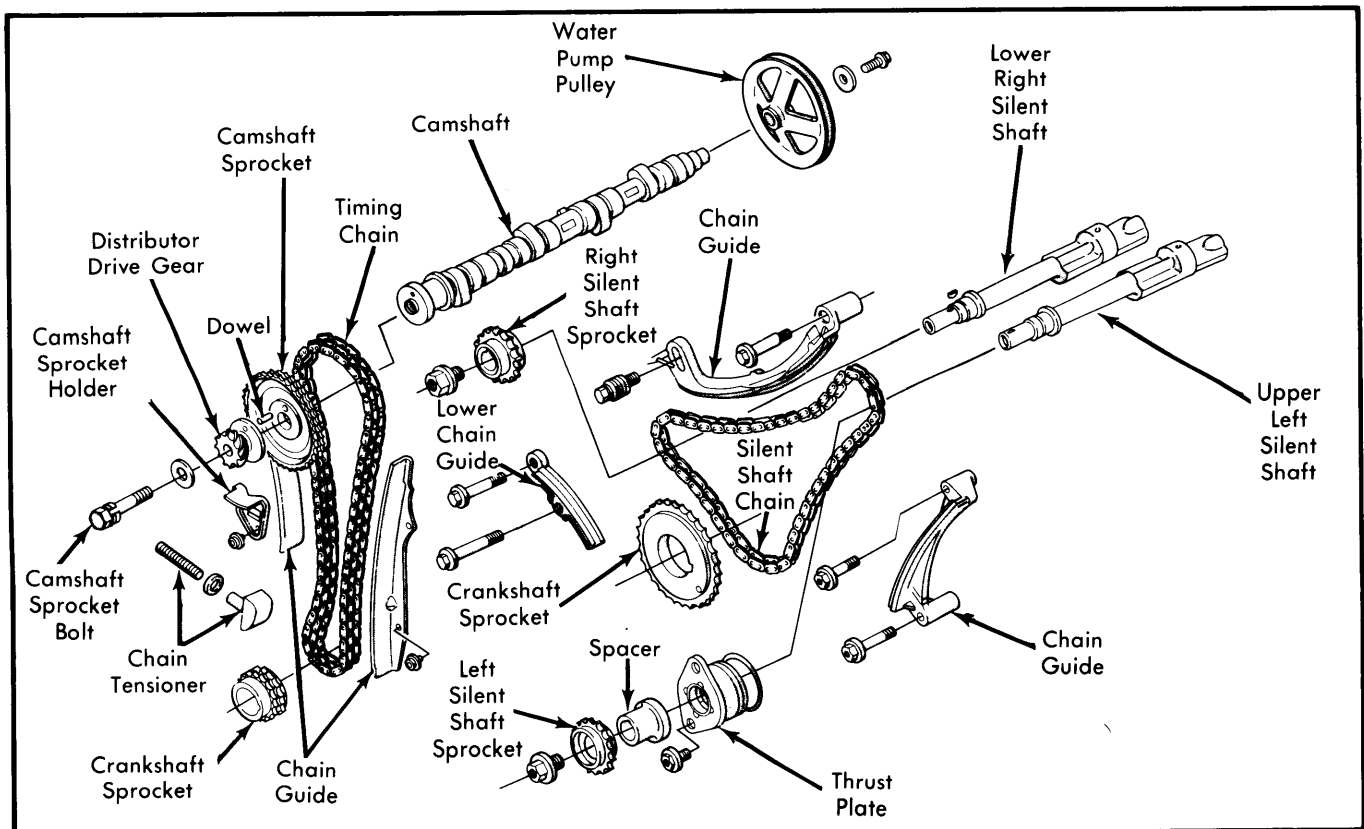

Fig. 7 Camshaft, Timing Chain, and Silent Shaft Assemblies

2.6L 4 CYLINDER (Cont.)

5) Fit gasket to cylinder head cover. Temporarily install breather, semi-circular seal and cylinder head cover. Start engine and run at idle speed until warm. Reset valves to specified hot settings.

6) Install breather and semi-circular seal to cylinder head, applying sealant as indicated in Fig. 2. Install and tighten cylinder head cover. Install distributor and connect spark plug cables, fuel pump, air cleaner and fuel line. Install breather hoses and purge hose.

TIMING CHAIN

Disassembly – 1) Disconnect battery, and remove alternator belt and alternator. Remove distributor, and remove and set aside the air conditioner compressor, if so equipped.

2) Remove power steering belt and power steering pump and bracket. Raise vehicle on hoist and remove right inner splash shield. Drain crankcase, and remove crankshaft drive pulley. Lower vehicle and place a jack under engine. Remove engine mounting screw, and raise engine slightly. Remove engine oil dipstick.

3) Remove air cleaner assembly and all spark plug wires. Remove cylinder head vacuum connections. Remove cylinder head cover. Remove ONLY the 2 front cylinder head bolts. Do not touch other cylinder head bolts. Remove oil pan, timing indicator, and engine mounting plate. Remove screws holding chain case cover and lift off cover.

4) Remove screws holding chain guides in position. Remove sprocket screws, drive chain, crankshaft sprocket and silent shaft sprockets. Remove camshaft sprocket screw, distributor drive gear, camshaft sprocket holder and right and left timing chain guides.

5) Depress tensioner to remove timing chain. Remove crankshaft sprocket and camshaft sprocket.

Reassembly – 1) Inspect all parts for cracks, wear or other damage. Check chain tensioner spring free length for 2.587" dimension. Rotate camshaft so that dowel hole is on upper vertical centerline. See Fig. 8.

2) Install sprocket holder and right and left chain guides. Rotate crankshaft until No. 1 piston is at TDC on compression stroke. Install tensioner spring and shoe on oil pump body.

3) Install timing chain on camshaft sprocket and crankshaft sprocket. Be sure timing marks on sprockets (punch marks on teeth) align with plated links of chain. See Fig. 9. Holding parts in both hands, align crankshaft sprocket to keyway and slide into place. Align camshaft sprocket dowel hole with camshaft dowel hole and install dowel.

4) Install sprocket screw on camshaft. Install silent shaft chain drive sprocket on crankshaft. Install chain to oil pump sprocket and to silent shaft sprocket. Be sure timing marks (punch marks on teeth) are aligned with plated links of chain. See Fig. 10.

5) Holding parts with both hands, align crankshaft sprocket timing mark with plated chain link. Install oil pump and silent chain sprockets to their respective shafts.

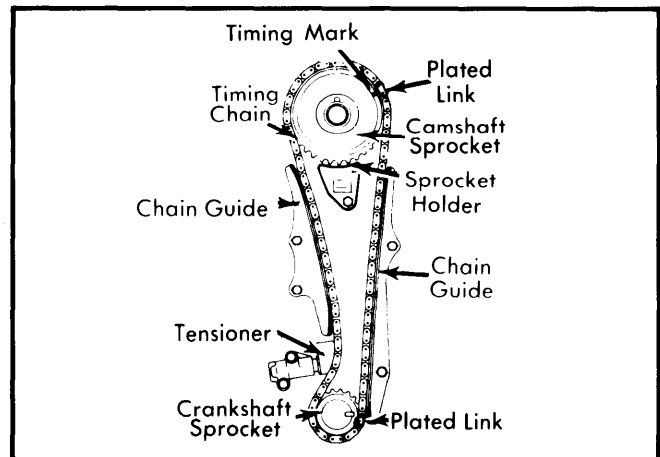

Fig. 9 Camshaft Sprocket Alignment and Installation

6) Install oil pump and silent shaft sprocket screws. Loosely install 3 chain guides. Adjust silent shaft tension by tightening chain guide "A" and "C". Then shake oil pump and silent shaft sprockets to collect chain slack at point "P" of Fig. 10.

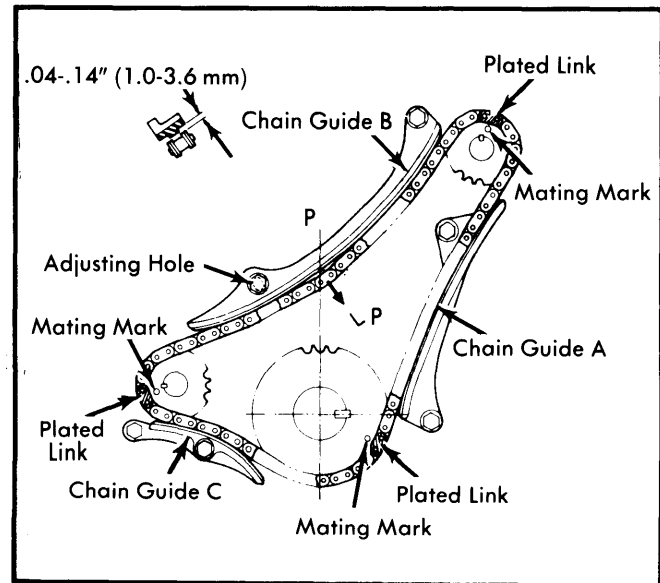

Fig. 10 Silent Shaft Drive Chain Installation

7) Adjust position of chain guide "B" so that when chain is pressed inward (arrow) with fingertips, clearance between chain guide "B" and chain links will be .04-.14". Tighten chain guide "B" mounting screws.

8) Install new chain case cover gaskets to cover, trimming as required to fit at top and bottom. Coat cover and gaskets with sealant (3419115), and install gasket and cover to cylinder block. Reinstall front 2 cylinder head bolts.

9) Remove cover from access hole in chain case cover. Loosen special bolt "B". See Fig. 11. Apply finger pressure only (no screwdrivers or punches) on boss in direction indicated. Tighten special bolt "B" to 15 ft. lbs. Complete reassembly by reversing disassembly procedure.

2.6L 4 CYLINDER (Cont.)

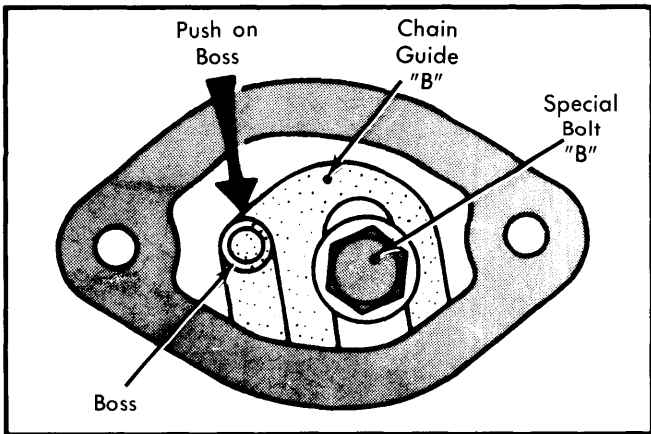

Fig. 11 Silent Shaft Chain Adjustment with Engine Installed

SILENT SHAFTS

Right Silent Shaft — With chains removed, remove oil pump mounting bolts. See Fig. 12. Remove bolt holding oil pump driven gear and silent shaft together. Remove oil pump and withdraw right silent shaft from bore. Reverse procedure to install. Prime oil pump and make sure oil pump mating marks align and that Woodruff key on shaft fits keyway in driven gear.

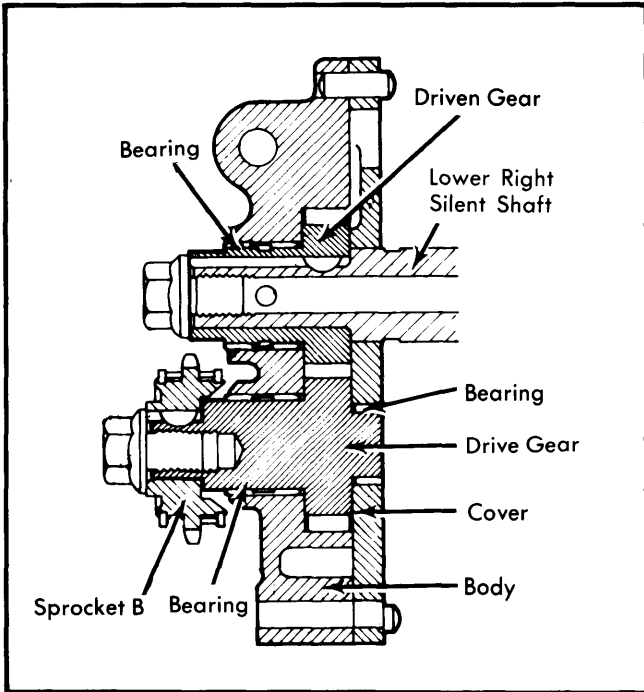

Fig. 12 Cutaway View of Gear Type Oil Pump

NOTE — If bolt holding oil pump driven gear is difficult to remove, remove oil pump and silent shaft as an assembly and then remove lock bolt.

Left Silent Shaft — Remove thrust plate supporting left silent shaft. Thrust plate is removed by threading bolts into plate holes at same time. Withdraw left silent shaft from cylinder block. Reverse procedure to install.

ENGINE OILING

ENGINE OILING SYSTEM

Crankcase Capacity — 5.0 qts. including .5 qt. for filter.

Oil Pressure — 50-64 psi@2000 RPM.

The 2.6L engine uses a gear-type oil pump with a force-feed lubrication system. Driven gear of oil pump also drives right silent shaft. See Fig. 13. For removal of oil pump, see *SILENT SHAFTS*.

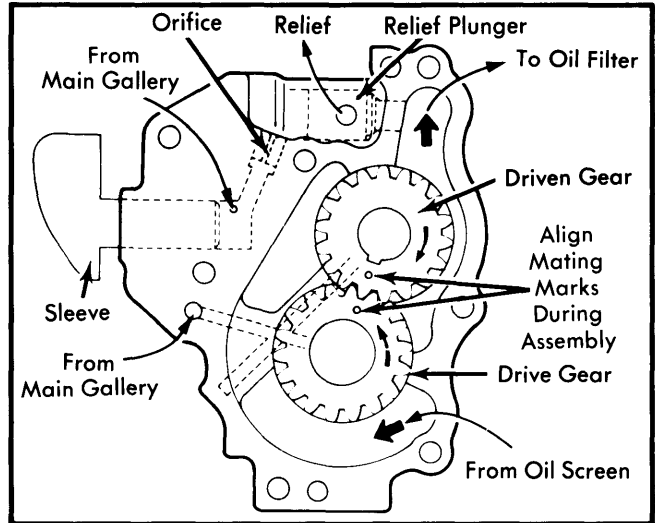

Fig. 13 Mating Marks for Oil Pump Gears

Oil Pump Specifications

Application	Clearance
Gear-to-Housing Clearance	.0043-.0059"
Driven Gear-to-Bearing Clearance	.0008-.0020"
Driven Gear-to-Bearing Clearance (Oil Pump Body)	.0008-.0020"
Driven Gear-to-Bearing Clearance (Oil Pump Cover)	.0016-.0028"
Gear End Play	.0024-.0047"
Relief Spring Free Length	1.850"
Relief Spring Load	9.5 lbs.@1.575"
Oil Pressure Switch Minimum Activating Pressure	4 psi or less

ENGINE COOLING

Cooling System Capacity — 8.7 qts.

Thermostat — 190° F.

Radiator Cap — 14-17 psi.

WATER PUMP

Removal & Installation — Drain cooling system. Remove radiator hose, by-pass hose and heater hose from water pump. Remove drive pulley shield. Remove locking screw and pivot screws. Remove drive belt and remove water pump from engine. To install, reverse removal procedure.

Remove drive belt and remove water pump from engine. To install, reverse removal procedure.

2.6L 4 CYLINDER (Cont.)

ENGINE SPECIFICATIONS

GENERAL SPECIFICATIONS						
Engine	Net HP At RPM	Torque (Ft. Lbs. at RPM)	Compr. Ratio	Bore	Stroke	Displ. Cu. Ins.
1981 2.6L	92@4500	131@2500	8.2:1	3.59"	3.86"	156

VALVES							
Engine & Valve ^①	Head Diam.	Face Angle	Seat Angle	Seat Width	Stem Diameter	Stem Clearance	Valve Lift
2.6L Intake	1.80"	45.25°	43.75°	.035-.051"	.315"	.0012-.0023"	.413"
2.6L Exhaust	1.50"	45.25°	43.75°	.035-.051"	.315"	.0020-.0035"	.413"

① — Jet valve and body not individually serviceable. Replace as an assembly only.

PISTONS, PINS, RINGS						
Engine	PISTONS	PINS		RINGS		
	Clearance	Piston Fit	Rod Fit	Rings	End Gap	Side Clearance
2.6L	.0008-.0016"	Press Fit 1614-3859 lbs.	Press Fit	No. 1 No. 2 No. 3	.001-.018" .001-.018" .008-.035"	.0024-.0039" .0008-.0024"

CRANKSHAFT MAIN & CONNECTING ROD BEARINGS							
Engine	MAIN BEARINGS				CONNECTING ROD BEARINGS		
	Journal Diam.	Clearance	Thrust Bearing	Crankshaft End Play	Journal Diam.	Clearance	Side Play
2.6L	2.362"	.0008-.0028"	No. 3	.002-.007"	2.087"	.0008-.0028"	.004-.010"

VALVE SPRINGS			
Engine	Free Length	PRESSURE (LBS.)	
		Valve Closed	Valve Open
2.6L	1.869"	61@1.59"

CAMSHAFT ^①			
Engine	Journal Diam. ^②	Clearance	Lobe Lift
2.6L	1.661"	.002-.004"	.413

① — End play is .004-.008".

② — Cam lobe height.

TIGHTENING SPECIFICATIONS	
Application	Ft. Lbs.
Camshaft Bearing Cap	13-14
Camshaft Sprocket	40
Cylinder Head Bolts (Cold)	69
Cylinder Head Bolts (Hot)	76
Cylinder Head-to-Chain Case Cover Bolt	13-14
Main Bearing Caps	58
Connecting Rod Caps	34
Crankshaft Pulley	87
Crankshaft Sprocket Bolt	87
Oil Pump Sprocket Bolt	25
Manifold Nuts	12-13
Water Pump Mounting Bolts	17
Jet Valve	14
Oil Pan Screws	13-14
Silent Chain Sprocket Bolts	25
Chain Guide Screws	13-14