

## 4.2 LITER 6 CYLINDER

### IDENTIFICATION CODING

#### ENGINE IDENTIFICATION

Engine number is located on machined pad on right side of cylinder block between number two and three cylinders. Letter contained in code number identifies engine by CID, carburetor type and compression ratio.

Engine Code	
Engine	Code
4.2L (258") .....	C

**NOTE** — Short block assemblies have an "S" stamped on same pad as engine identification number. Engines built for sale in Georgia and Tennessee have an additional nonrepeating number below identification number.

#### SPECIAL ENGINE MARKS

Some engines are produced with oversize or undersize components. These engines are identified by a letter code stamped on boss between ignition coil and distributor. Letters are decoded as follows:

- B — All cylinder bores .010" oversize.
- C — All camshaft bearing bores .010" oversize.
- M — All main bearing journals .010" undersize.
- P — All connecting rod journals .010" undersize.

#### ENGINE REMOVAL

See *Engine Removal* at end of *ENGINE* Section.

### CYLINDER HEAD & MANIFOLDS

#### INTAKE & EXHAUST MANIFOLDS

**Removal** — 1) Drain coolant. Remove air cleaner. Disconnect fuel pipe, carburetor air horn vent hose and idle speed solenoid wire connector. Disconnect clean air tube and choke heater wire connector.

2) Disconnect heater hose from intake manifold and throttle cable from bellcrank. Disconnect PCV and CTO valve vacuum hoses. Disconnect feedback system coolant temperature sender wire, EGR vacuum hose and intake manifold electric heater wire connector.

3) Disconnect air guard hoses at air pump and air injection manifold check valve. Disconnect and remove diverter valve with air hoses. Remove air pump/power steering mounting bracket, if equipped. Remove air pump.

4) Detach power steering pump and set aside, but do not remove hoses. Remove air conditioning compressor drive belt idler pulley assembly from cylinder head, if equipped. On automatic transmission models, disconnect throttle valve linkage.

5) Disconnect exhaust pipe from manifold flange. Disconnect oxygen sensor wire connector and remove oxygen sensor, if equipped. Disconnect EGR tube from intake manifold.

6) Remove intake manifold attaching screws and remove manifold. Remove remaining screws and remove exhaust manifold. Discard gaskets and clean manifold mating surfaces.

**Installation** — 1) Position exhaust manifold over studs on cylinder head, and hold in place with bolt No. 12. Position intake manifold gasket and manifold over cylinder head dowels and tighten bolts in sequence shown in *Fig. 1*.

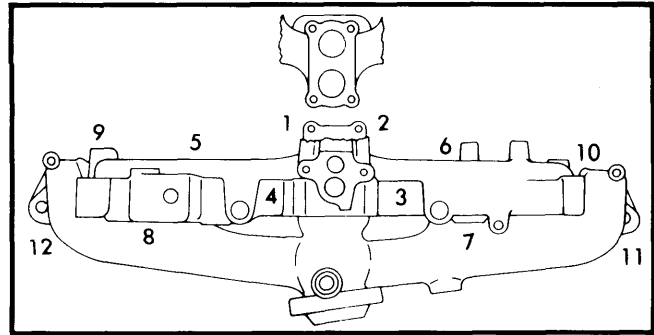

**Fig. 1 Intake Manifold Tightening Sequence**

2) Tighten all manifold attaching bolts to 23 ft. lbs. To complete installation, reverse removal procedures.

#### CYLINDER HEAD

**Removal** — 1) Drain cooling system and disconnect hoses at thermostat housing. Remove air cleaner, fuel line and vacuum advance line. Remove rocker arm cover, rocker arms and bridged pivot assembly (back off each screw one turn at a time to avoid breaking bridge).

2) Remove push rods, keeping the push rods, bridged pivots and rocker arms in same order as removed. Disconnect power steering pump and air guard bracket. Take off intake and exhaust manifold assembly.

3) If equipped with air conditioning, remove drive belt idler bracket from cylinder head. Loosen alternator drive belt, remove bolts from air compressor mounting bracket and set compressor aside. Remove spark plugs.

4) Take off temperature sending unit wire and battery ground cable. Remove ignition coil and bracket assembly, remove cylinder head bolts and lift off cylinder head.

**Installation** — 1) Clean and inspect all parts thoroughly. Transfer all attached components from original head not included with replacement head.

2) Clean block and cylinder head surfaces carefully, apply even coat of sealing compound to both sides of new head gasket and position on block assembly with word "TOP" facing upward.

3) Install cylinder head and tighten all bolts in sequence shown in *Fig. 2*. Reverse removal procedure to replace all remaining components, noting that temperature sender should not be installed until engine is filled with coolant. Retightening of head bolts is not necessary.

## 4.2 LITER 6 CYLINDER (Cont.)

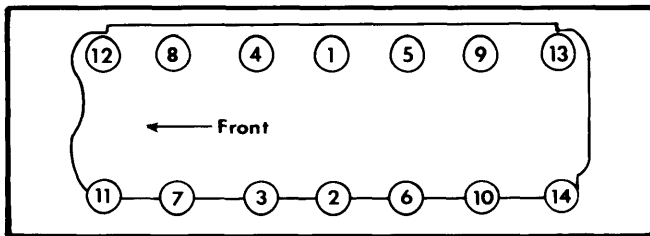

Fig. 2 Cylinder Head Tightening Sequence

### VALVES

#### VALVE ARRANGEMENT

E-I-I-E-I-E-E-I-E-I-E (front to rear).

#### VALVE GUIDE SERVICING

Valve guides are integral with cylinder head. If valve stem-to-guide clearance is not within specifications, ream guide to install valve with oversize stem. Valves are available in .003", .015" and .030" oversize.

**CAUTION** — Ream valve guides in steps, starting with .003" reamer and progressing to size required.

#### VALVE STEM OIL SEALS

Nylon oil deflectors are used as seals on all valves. These should always be replaced when valves are serviced. If oversize valves are used, install oversize oil deflectors.

#### VALVE SPRINGS

**Removal** — 1) Remove rocker arm cover, rocker arms and bridged pivot assemblies. Remove push rods and spark plug of cylinder to be worked on.

2) Install suitable air line adapter to spark plug hole and apply air pressure to hold valve in place.

3) Use suitable removal and installation tool (J-22534-01) to compress spring enough to remove valve locks. Remove spring, retainer and oil deflectors.

**Installation** — 1) Install new oil deflector, valve spring and retainer. Using same tool used for removal, compress valve spring, insert valve locks and release spring tension.

2) Tap spring from side to side to insure that spring is properly seated. Reverse removal procedure to complete installation.

#### ROCKER ARM ASSEMBLY

Rocker arm assemblies consist of stamped rocker arms, bridged pivot assembly and rocker arm cap screws. When removing or installing bridged pivot, loosen or tighten rocker arm cap screws only one turn at a time to avoid breaking bridge. See Fig. 3.

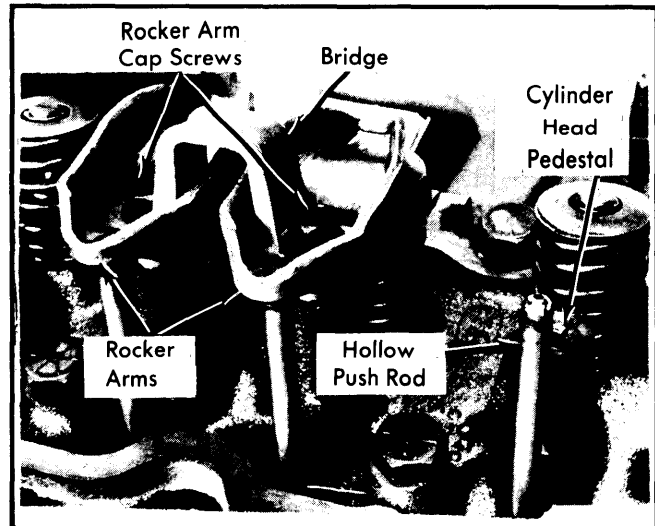

Fig. 3 Installed View of Bridged Pivot Assembly

#### HYDRAULIC LIFTER ASSEMBLY

Lifters are serviced as complete assemblies only and parts are not interchangeable between lifters. Inspect for signs of scuffing on barrel and face of lifter body. If concave face wear is present, replace camshaft and lifters. If lifters are disassembled for cleaning and inspection, reassemble and test with a leakdown tester according to manufacturer's instructions. Discard lifters not within specifications.

**NOTE** — Do not fill lifter assemblies with engine oil prior to installation, as they will charge themselves within 3 to 8 minutes of engine operation.

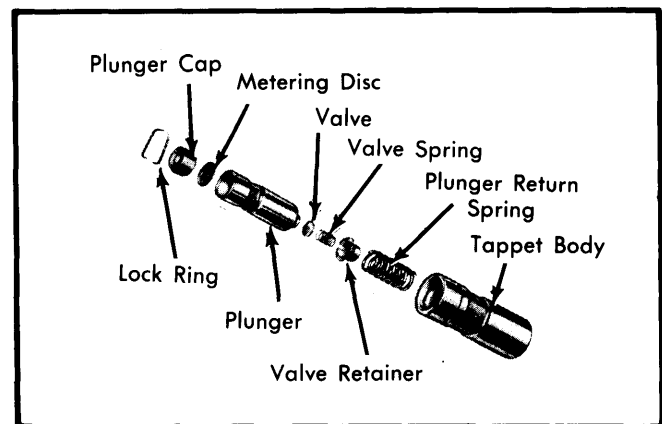

Fig. 4 Exploded View of Hydraulic Lifter Assembly

### PISTONS, PINS & RINGS

#### OIL PAN

See Oil Pan Removal at end of ENGINE Section.

#### PISTON & ROD ASSEMBLY

**NOTE** — New pistons must be installed in same cylinders for which they were fitted, and used pistons in same cylinder from which they were removed.

## 4.2 LITER 6 CYLINDER (Cont.)

**Removal** – 1) With cylinder head and oil pan removed, use a ridge reamer to remove any ridge or deposits on upper end of cylinder bore.

**NOTE** – Piston must be at bottom of stroke and covered with cloth to collect cuttings.

2) Remove connecting rod bearing caps and retain in same order as removed. Install rubber hose over connecting rod studs to protect cylinder walls and push piston and rod assembly out top of cylinder block.

**NOTE** – Caps and rods are stamped with corresponding cylinder number.

**Installation** – 1) Position rings on pistons according to ring gap positions as shown in Fig. 5. Upper and lower compression ring markings indicate top side of ring.

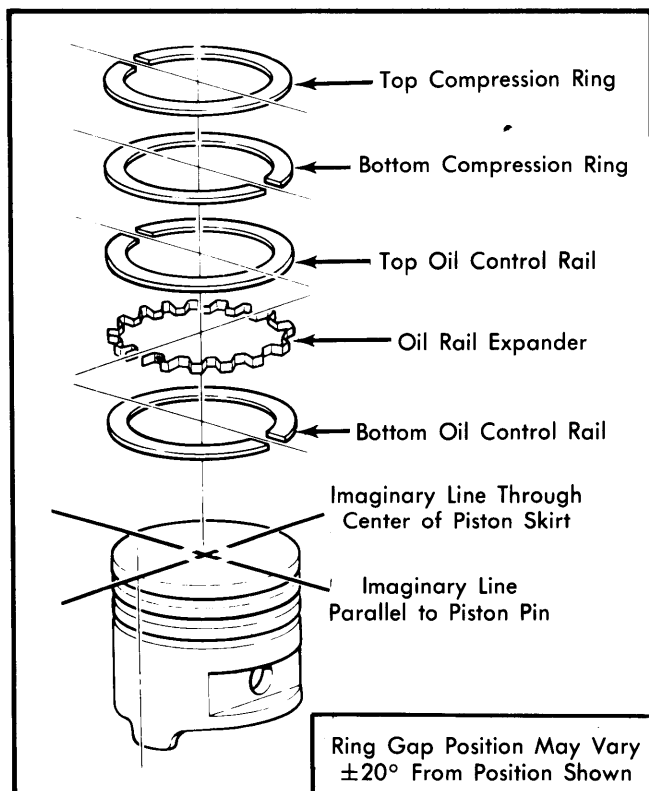

**Fig. 5** Piston Ring Gap Positions

2) Lightly coat pistons, rings and cylinder walls with engine oil. Install suitable ring compressor on pistons ensuring that ring gap positions do not change. With connecting rod studs covered for cylinder wall protection, install each piston and rod assembly. Be sure arrow on top of piston faces front of engine and that each piston is fitted to appropriate bore.

**NOTE** – Oil holes in connecting rods must face toward camshaft.

3) Guide connecting rod onto crankshaft journal while tapping down on piston using suitable tool. Carefully seat connecting rod against crankshaft and install mating rod cap. Tighten connecting rod nuts to specified torque.

## FITTING PISTONS

Measure cylinder bore diameter  $2 \frac{5}{16}$ " below top of cylinder bore. Measure piston at right angles to piston pin at centerline of pin.

## PISTON PINS

**Removal** – Place piston on support and using suitable tool set (J-21872-1, 2 & 3), press pin from piston and rod with arbor press. Note position of pin through gauge window of remover support. See Fig. 6.

**Installation** – Using suitable pilot, driver and support (J-21872), press piston pin through connecting rod and piston until pin pilot indexes with mark on support. Pin should be centered in rod plus or minus  $\frac{1}{32}$ ". Check piston for freedom of movement on pin.

**NOTE** – Never reuse a piston pin once it has been removed from piston and rod assembly. If little effort is required to install new piston pin in connecting rod, or if rod moves along pin, a new connecting rod is required.

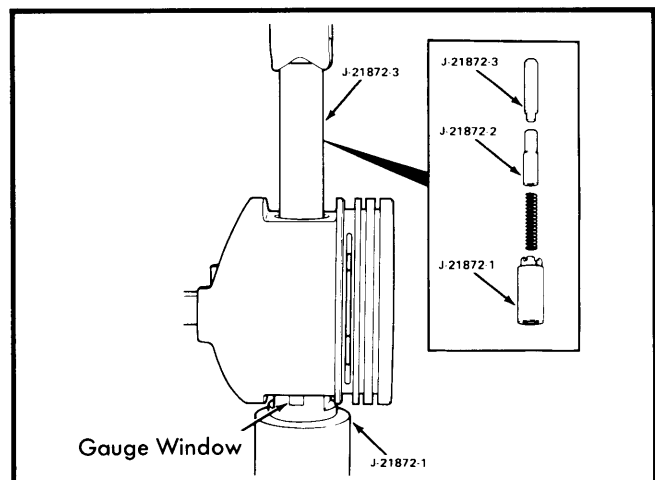

**Fig. 6** Special Tool Set Up for Piston Pin Removal and Installation

## CRANKSHAFT &amp; ROD BEARINGS

## MAIN &amp; CONNECTING ROD BEARINGS

**Connecting Rod Bearings** – After ensuring rod caps are marked for cylinder identification, remove rod caps. Use Plastigage method to check for proper bearing clearances. If not within specifications, new bearings must be installed. New bearings are available in .001", .002", .010" and .012" undersize. Selective fitting is required on each connecting rod. A standard bearing may be used in combination with a .001" undersize or a .002" undersize in combination with a .001" undersize. Coat bearing surfaces with oil, install rod cap and tighten nuts.

**NOTE** – Never use a new bearing with a used bearing. Never use a pair of bearings with more than .001" difference in size on same journal.

**Main Bearings** – 1) Support crankshaft at counterweight adjacent to main bearing being checked and ensure that all

## 4.2 LITER 6 CYLINDER (Cont.)

bearing caps other than one being checked are tight. Starting with rear main bearing cap and working forward, remove one cap at a time and check bearing clearances using Plastigage method.

2) If clearances are not within specifications, bearings are available in .001", .002", .010" and .012" undersize. A standard bearing may be used in combination with a .001" undersize or a .002" undersize in combination with a .001" undersize.

**NOTE** — Never use a new bearing with a used bearing. Never use a pair of bearings with more than .001" difference in size on same journal.

3) Remove all upper bearings by inserting suitable tool in oil hole of crankshaft journal and rotating crankshaft clockwise to roll bearing from engine. Oil new bearing and rotate crankshaft so bearing will rotate in direction of its locating tang. Install bearing cap with lower bearing and tighten bolts.

### THRUST BEARING ALIGNMENT

When replacing thrust bearings (located at No. 3 main bearing journal), crankshaft should be moved fore and aft to align thrust faces of bearings.

### REAR MAIN BEARING OIL SEAL

**Removal** — Remove oil pan and rear main bearing cap. Loosen all remaining main bearing bolts. Using a brass drift, tap upper seal until seal is protruding enough to pull it completely out. Remove lower seal from bearing cap.

**Installation** — Reverse removal procedure while noting the following: Lip of seal must face toward front of engine. Ensure seal is firmly seated in bearing cap recess. Use suitable sealer and apply as indicated in Fig. 7.

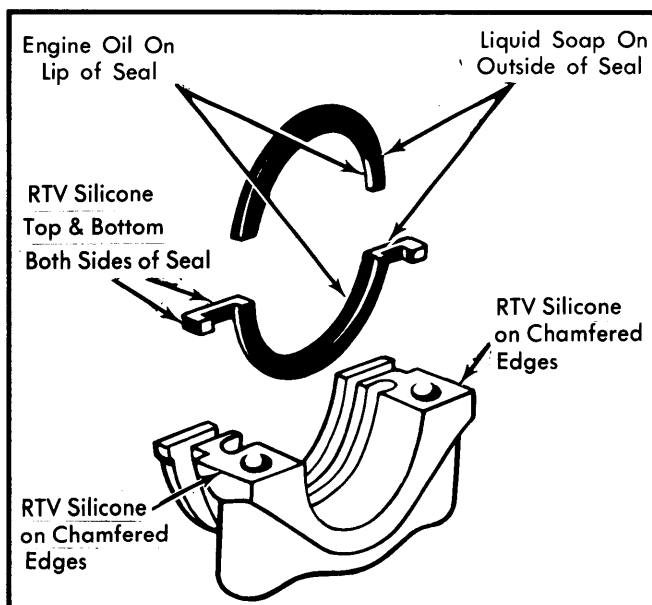

**Fig. 7 Rear Main Oil Seal Installation Instructions (Note Where RTV Silicone Should be Applied)**

## CAMSHAFT

### ENGINE FRONT COVER

**Removal** — 1) Remove drive belt(s), fan and hub assembly, accessory pulley (if equipped) and vibration damper. Remove oil pan-to-timing chain cover screws and cover-to-block screws.

2) Remove cover, front seal and gasket. Cut off oil pan side gasket end tabs flush with front of block and remove gasket tabs.

**Installation** — 1) Clean all gasket mounting surfaces. Apply suitable sealing compound to both sides of cover gasket and position on cylinder block.

2) Cut end tabs of a new oil pan seal as described under removal and position seal on cover after using suitable sealer on seal end tabs. Position engine front cover on cylinder block.

3) Use suitable tool (J-22248) to align front cover and install cover-to-block screws and oil pan-to-cover screws. Tighten all screws. Remove alignment tool and install vibration damper, pulley, fan and hub assembly and drive belt(s).

### FRONT COVER OIL SEAL

**Removal & Installation** — Remove drive belt(s), accessory drive pulley and vibration damper. Remove oil seal using suitable tool (J-9256) or equivalent. To install new seal, apply light film of proper sealer on outside diameter of seal and position on cover with seal lip facing outward. Use suitable tools (J-9163 & J-22248) or equivalent to press seal into cover until it bottoms. Apply light film of engine oil on seal lip and install vibration damper, accessory drive pulley and drive belt(s).

### TIMING CHAIN

**Removal** — Remove engine front cover and oil seal. Remove camshaft sprocket retaining bolt and washer. Rotate crankshaft until timing mark on sprocket is aligned with camshaft sprocket timing mark. See Fig. 8. Remove sprockets and timing chain assembly.

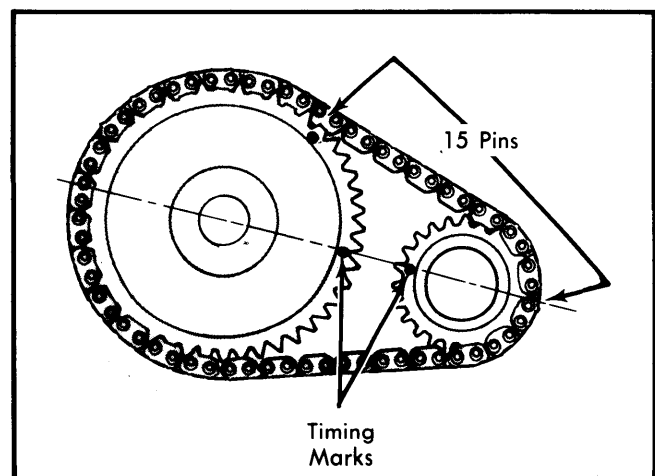

**Fig. 8 Timing Chain Sprocket Alignment**

## 4.2 LITER 6 CYLINDER (Cont.)

**Installation** — Assemble timing chain, crankshaft sprocket and camshaft sprocket with timing marks aligned. See Fig. 8. Install assembly to crankshaft and camshaft. Install camshaft sprocket retaining bolt and washer and tighten.

**NOTE** — To ensure proper installation of timing chain, rotate crankshaft until timing mark on camshaft is at approximately 1 o'clock position. See Fig. 8. Timing mark of crankshaft sprocket then should be fully meshed with timing chain, with 15 pins between timing marks. If not, remove and install once more. Also, if chain deflects more than 1/2 inch, it should be replaced.

**CAMSHAFT**

**Removal** — 1) Drain cooling system and remove radiator. Lift off air conditioning condenser and receiver assembly as a charged unit (if equipped). Remove fuel pump, distributor and ignition wires. Remove rocker arm cover and valve assembly components.

2) Remove cylinder head and gasket. Remove lifters. Remove timing case cover, timing chain and sprockets. Remove front bumper or grille as required, and remove camshaft.

**Installation** — Reverse removal procedures while noting the following: Lubricate camshaft with suitable oil supplement and install camshaft carefully to avoid damaging lobes. Install distributor so that rotor is aligned with No. 1 terminal of cap when distributor is fully seated.

**CAMSHAFT BEARINGS**

**Removal & Installation** — Engine must be removed to replace camshaft bearings. With camshaft removed, remove bearings using suitable bearing remover. Install with a screw-type tool that provides steady pressure. Do not use a driver-type tool. Ensure that oil holes in bearings are aligned with oil galleries in block. It is not necessary to line ream bearings after installation.

**CAM LOBE LIFT**

Remove rocker arm cover, rocker arm assembly and spark plugs. Proceed as follows:

1) Using suitable clamping or mounting fixture, attach dial indicator to cylinder so indicator probe rests on top of push rod in a vertical position. Install a piece of rubber tubing between push rod and indicator plunger.

2) Rotate crankshaft slowly until valve lifter is on heel of cam lobe. At this point, push rod will be at its lowest point.

**CAUTION** — If using an auxiliary starter switch, distributor primary lead must be disconnected from negative post of coil.

3) With push rod at lowest position, zero dial indicator and rotate engine until push rod is in fully raised position. Compare total lift recorded with specifications. If less than specifications, camshaft is defective. Check all remaining lobes of camshaft in same manner.

**VALVE TIMING**

Remove spark plugs and rocker arm cover. Rotate crankshaft until No. 6 piston is at TDC on compression stroke. Rotate

crankshaft counterclockwise 90°. Install dial indicator on end of No. 1 cylinder push rod, with a piece of rubber hose between indicator and push rod. Set dial indicator at zero. Rotate crankshaft clockwise until dial indicator shows .012" lift. Timing mark on vibration damper should index with TDC mark on engine front cover. If timing mark is more than 1/2" off TDC in either direction, valve timing is incorrect.

**ENGINE OILING**

**Crankcase Capacity** — 4 quarts. Add 1 quart with filter change.

**Oil Filter** — Replace every 7,500 miles or 7 months, whichever comes first.

**Normal Oil Pressure** — 13 psi minimum at 600 RPM and 37-75 psi maximum at 1600+ RPM.

**Pressure Regulator Valve** — Located in pump body. Not adjustable.

**ENGINE OILING SYSTEM**

Oil under pressure is directed from oil pump to a fullflow oil filter. In case filter becomes clogged and restricts flow of oil, bypass valve is located in filter mounting base. See Fig. 9. From oil filter, oil flow is directed as follows:

**Crankshaft & Camshaft Bearings** — Main and camshaft bearings receive oil from main oil gallery. From main bearings oil passes through passage in crankshaft to connecting rod bearings. Oil throw-off from each connecting rod bearing lubricates cylinder walls, piston pins, camshaft lobes and distributor drive gear.

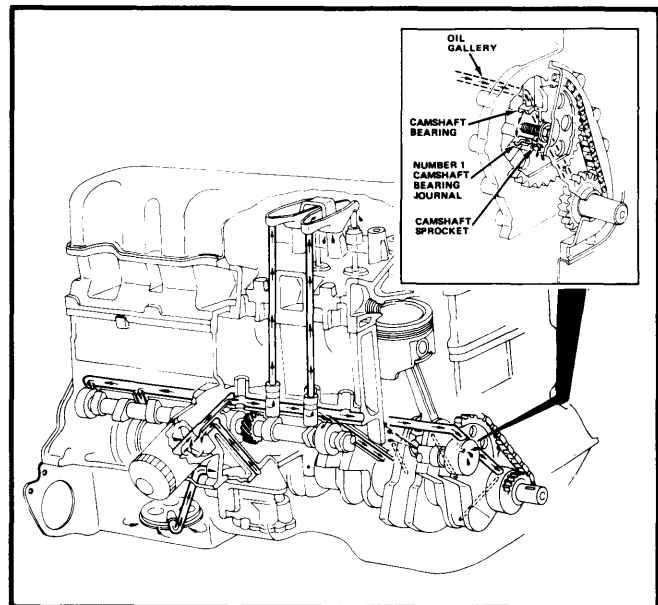

Fig. 9 Engine Oil Circuit Diagram

**Hydraulic Valve Lifters** — Lubricated directly from main oil gallery.

**Timing Chain & Sprockets** — Oil is received from front camshaft bearing and returns to crankcase through cavity under front main bearing cap.

## 4.2 LITER 6 CYLINDER (Cont.)

**Rocker Arms & Bridged Pivot Assemblies** – Oil is supplied to rocker arms from hydraulic valve lifters through hollow push rods to rocker arm assemblies. Oil from rocker arms lubricate valve train components, then passes down through push rod guides and into oil pan.

should be .0005-.0025" with .0005" preferred. Measure between gears and wall of cavity opposite point of gear mesh. Pump must be filled with petroleum jelly or equivalent prior to installation of pump cover. See Fig. 10.

### OIL PUMP

Oil pump is driven by distributor drive shaft. Removal of oil pump will not effect ignition timing, as distributor gear remains meshed with camshaft gear. Remove pump cover and gasket. Measure end clearance of pump gears. Place suitable straightedge across gears and pump body. Pass feeler gauge between straightedge and gears. Correct clearance is .002-.004" with .002" preferred. Oil pump gear-to-body clearance

**CAUTION** – Oil inlet tube position must be changed to allow removal of relief valve. Pickup tube assembly must be replaced at installation using suitable sealer.

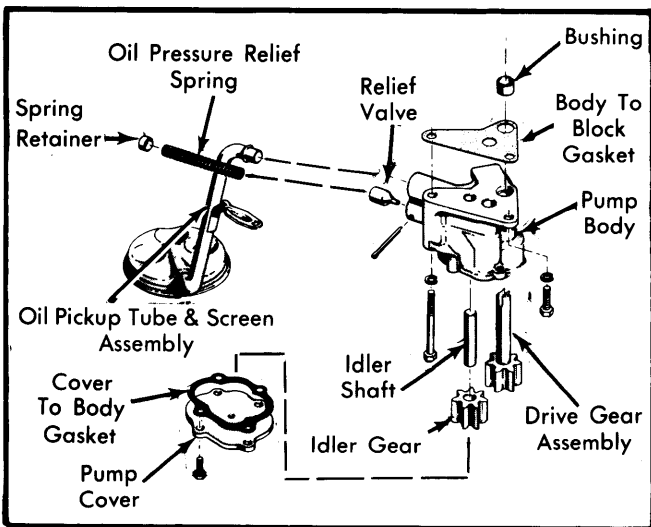

Fig. 10 Exploded View of Oil Pump Assembly

### TIGHTENING SPECIFICATIONS

Application	Ft. Lbs.
Camshaft Sprocket .....	50
Clutch Housing-to-Block	
Top .....	27
Bottom .....	43
Connecting Rod Nuts .....	33
Cylinder Head .....	85
Drive Plate-to-Converter .....	22
Engine Front Cover .....	5
Exhaust Manifold .....	23
Flywheel-to-Crankshaft .....	105
Fuel Pump .....	16
Intake Manifold .....	23
Main Bearing Caps .....	65
Oil Pan	
1/4" .....	7
5/16" .....	11
Oil Pump Cover .....	6
Oil Pump Screw	
Short .....	10
Long .....	17
Thermostat Housing .....	13
Vibration Damper (Lubricated) .....	80
Water Pump .....	13

### ENGINE SPECIFICATIONS

GENERAL SPECIFICATIONS						
Engine	Net HP At RPM	Torque (Ft. Lbs. at RPM)	Compr. Ratio	Bore	Stroke	Displ. Cu. Ins.
258" 2-Bbl.	110@3200	210@1800	8.3:1	3.75"	3.895"	258

VALVES							
Engine & Valve	Head Diam.	Face Angle	Seat Angle	Seat Width	Stem Diameter	Stem Clearance	Valve Lift
258" 2-Bbl.							
Int.	1.782"	29°	30°	.040-.060"	.3715-.3725"	.001-.003"	.....
Exh.	1.401"	44°	44.5°	.040-.060"	.3715-.3725"	.001-.003"	.....

# American Motors 6 Engines

## 4.2 LITER 6 CYLINDER (Cont.)

### ENGINE SPECIFICATIONS (Cont.)

VALVE SPRINGS			
Engine	Free Length	PRESSURE (LBS.)	
		Valve Closed	Valve Open
		258"	1.99"

VALVE TIMING				
Engine	INTAKE		EXHAUST	
	Open (BTDC)	Close (ABDC)	Open (BBDC)	Close (ATDC)
	258"	9°	73°	57°

PISTONS, PINS, RINGS						
Engine	PISTONS	PINS		RINGS		
	Clearance	Piston Fit	Rod Fit	Rings	End Gap	Side Clearance
	258"	.0009-.0017"	.0003-.0005"	2000 lbs. Press Fit	1 2 3	.010-.020" .010-.020" .010-.025"

CRANKSHAFT MAIN & CONNECTING ROD BEARINGS							
Engine	MAIN BEARINGS				CONNECTING ROD BEARINGS		
	Journal Diam.	Clearance	Thrust Bearing	Crankshaft End Play	Journal Diam.	Clearance	Side Play
	258"	2.4986"	.001-.003"	3	.0015-.0065"	2.0934"	.001-.003"

CAMSHAFT			
Engine	Journal Diam.	Clearance	Lobe Lift
258"			
No. 1	2.029-2.030"	.001-.003"	.253"
No. 2	2.019-2.020"		
No. 3	2.009-2.010"		
No. 4	1.999-2.000"		