

## AMERICAN MOTORS MODEL 119

## Eagle

## DESCRIPTION

Eagle models are equipped with the model 119 full time four-wheel drive transfer case. This unit provides fully differentiated four-wheel drive in all operating conditions. The model 119 is a single range unit. Four-wheel drive range is automatic and does not require any external linkage to achieve four-wheel operation. The 119 provides fully differentiated operation which is accomplished through a torque biasing viscous coupling and an open differential connected to the coupling. Two drive sprockets and an interconnecting drive chain are used to distribute torque to the front and rear propeller shafts. The 119 case assembly is made of cast aluminum and consists of front and rear case halves and a rear retainer.

## LUBRICATION

## SERVICE INTERVAL

Check transfer case fluid level at every oil change. Change fluid every 15 months or 15,000 miles.

## FLUID TYPE

Use a quality grade 10W-30 motor oil only.

## CAPACITY

Capacity is 4 pints.

## TROUBLE SHOOTING

## LUBRICANT LEAKS PAST YOKE OR OUT OF VENT

Overfilled condition or vent could be closed or restricted. Yoke seal could be worn or damaged.

## NOISY OPERATION

Incorrect or insufficient lubrication. Incorrect tire pressure. Mismatched or unequal tire sizes and type.

## REMOVAL &amp; INSTALLATION

## TRANSFER CASE

**Removal** – 1) Raise vehicle, support engine and transmission with support stand or transmission jack. Disconnect catalytic converter support bracket at adapter housing. Remove skid plate, speedometer cable, and adapter from transfer case.

2) Mark propeller shafts and transfer case yokes for assembly reference. Disconnect propeller shafts at yokes. Disconnect gear shift and throttle linkage at transmission. Remove crossmember, remove transfer case-to-adapter housing nuts and remove transfer case.

**Installation** – To install transfer case, reverse removal procedure.

## DISASSEMBLY

## TRANSFER CASE

1) Drain lubricant from transfer case. Remove front and rear yokes. Mark rear retainer and rear case for assembly reference. Remove rear retainer bolts and remove retainer. Remove differential shims and speedometer drive gear from output shaft See Fig. 1.

**CAUTION** – Insert the screwdriver in the slots at each end of the rear case to loosen it. Do not attempt to wedge the case halves apart or the case mating surfaces will be damaged.

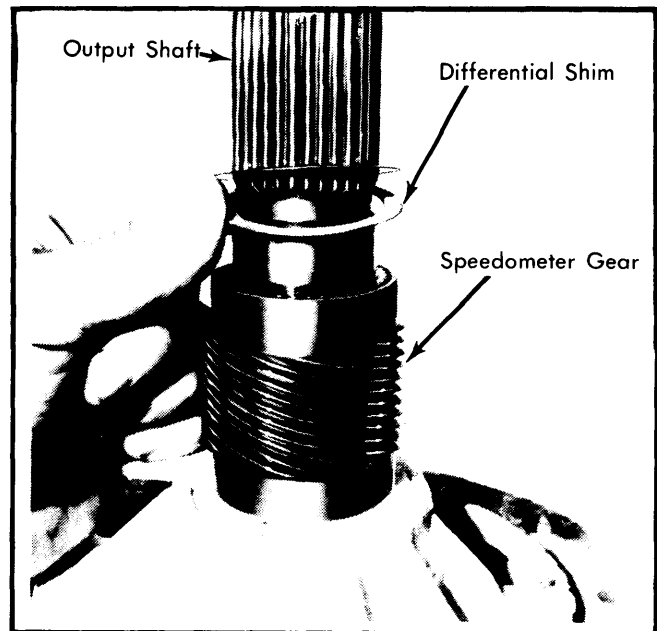

Fig. 1 Speedometer Gear and Differential Shim

2) Remove thrust bearings and races from front output shaft. Remove oil pump from rear output shaft. Note position of pump for assembly reference, recessed side of pump faces case interior. Remove rear output shaft from viscous coupling. Remove 15 mainshaft pilot bearing rollers from shaft or coupling if rollers dropped off during removal of rear output shaft. Remove mainshaft "O" ring from end of shaft. Remove viscous coupling from mainshaft side gear.

3) Remove front output shaft and driven sprocket as an assembly. Lift front shaft, sprocket and chain upward. Tilt front shaft toward mainshaft. Slide chain off drive sprocket and remove assembly. Remove front output shaft front thrust bearing assembly from front case, or from shaft if bearing and races remained on shaft during removal. Remove drive chain from front output shaft and sprocket, remove snap ring that retains driven sprocket on front output shaft. Mark sprocket and shaft for assembly reference and remove sprocket from shaft.

4) Remove mainshaft, side gear, clutch gear, drive sprocket and spline gear as an assembly. Place assembly on clean surface. Remove range fork, rail and clutch sleeve as an assembly. Mark sleeve and fork for reassembly reference and remove sleeve from fork. Remove mainshaft thrust washer from input gear, remove input gear and input thrust bearing and race. Remove detent ball, spring and bolt. Remove range sector shaft retaining nut and washer.

## AMERICAN MOTORS MODEL 119 (Cont.)

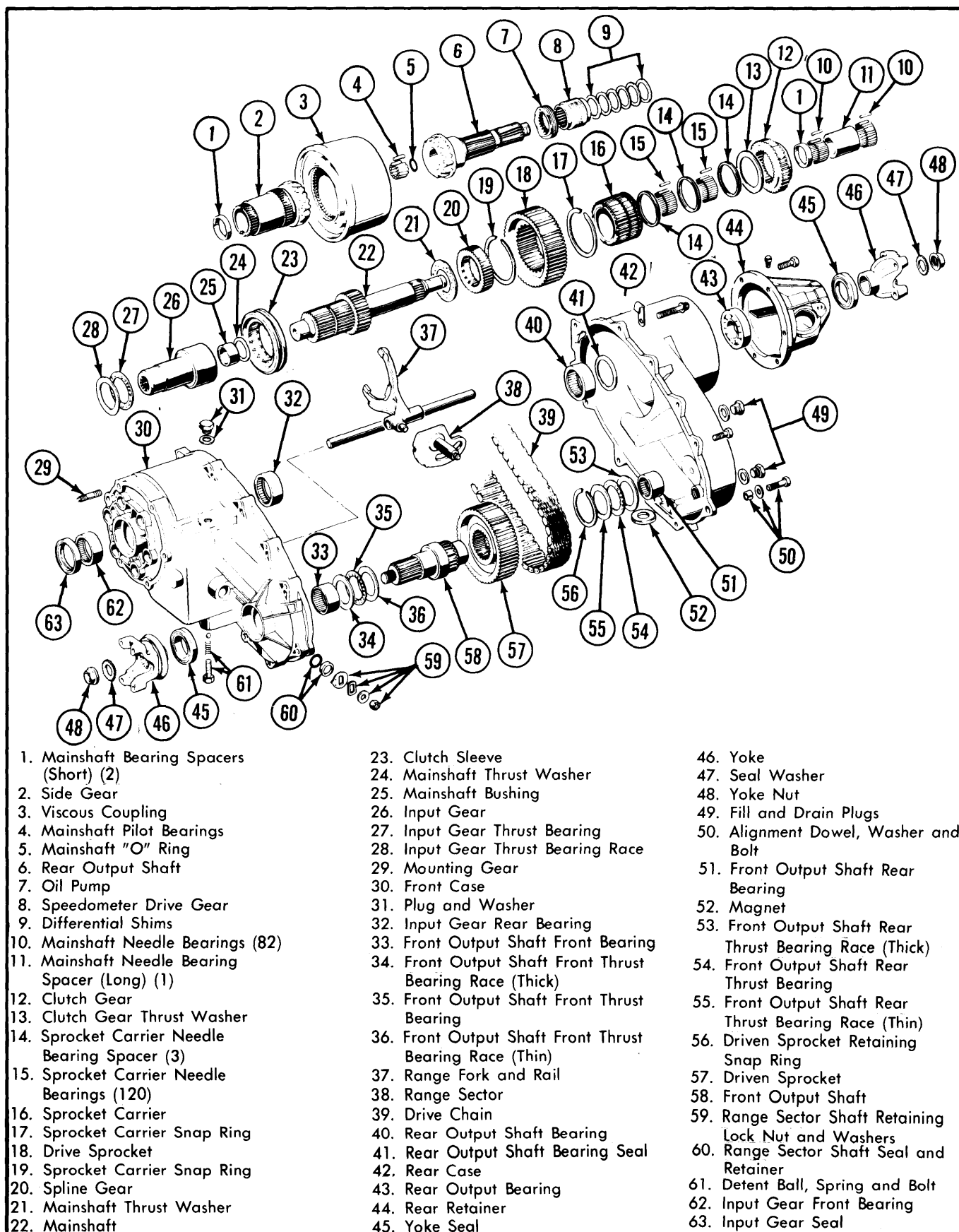

Fig. 2 Exploded View of Model 119 Transfer Case

## AMERICAN MOTORS MODEL 119 (Cont.)

5) Remove range sector shaft retaining nut and washers. Remove range sector. Tap sector shaft with plastic mallet to remove shaft from case bore. Remove range sector shaft "O" ring seal and seal retainer from bore in case.

## MAINSHAFT

1) Grasp drive sprocket and lift sprocket, clutch gear and side gear upward and off mainshaft. See Fig. 3. Remove mainshaft needle bearings and 3 bearing spacers from mainshaft. A total of 82 bearings are used. Note spacer position for reassembly reference.

2) Remove spline gear and thrust washer from mainshaft. Remove side gear, clutch gear and clutch gear thrust washer from sprocket carrier and sprocket. Remove clutch gear and thrust washer from side gear.

3) Remove 1 sprocket carrier snap ring and remove drive sprocket from carrier. Mark sprocket and carrier for reassembly reference. Remove 3 bearing spacers and all sprocket carrier needle bearings from carrier. A total of 120 needle bearings are used.

**NOTE** — The sprocket carrier and mainshaft needle bearings are different sizes. Take care to avoid intermixing them.

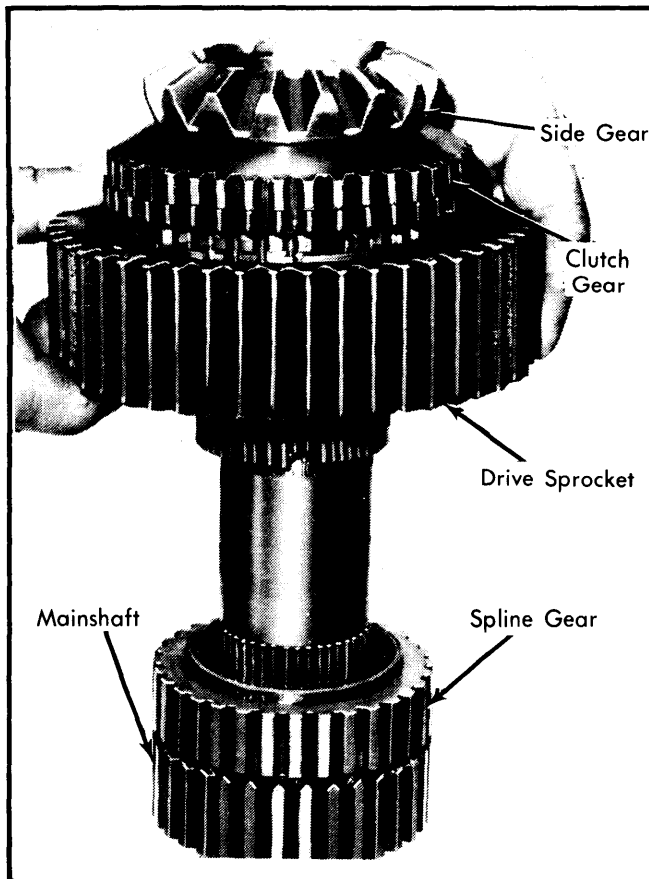

**Fig. 3** Drive Sprocket, Clutch Gear, Side Gear and Sprocket Carrier

## CLEANING &amp; INSPECTION

1) Clean all parts in suitable cleaning solvent. Be sure all old lubricant or foreign material is removed from surfaces of every part. Apply compressed air to blow dry parts.

2) Inspect all gear teeth for signs of excessive wear or damage and check all gear splines for burrs, nicks, wear or damage. Remove minor nicks or scratches using an oilstone. Replace any part exhibiting excessive wear or damage.

3) Inspect case halves and rear retainer for cracks, porosity, damaged mating surfaces, stripped bolt threads or distortion.

4) Inspect the condition of all bearings. Also check the condition of all bearing bores. Replace any part that exhibits signs of wear or damage.

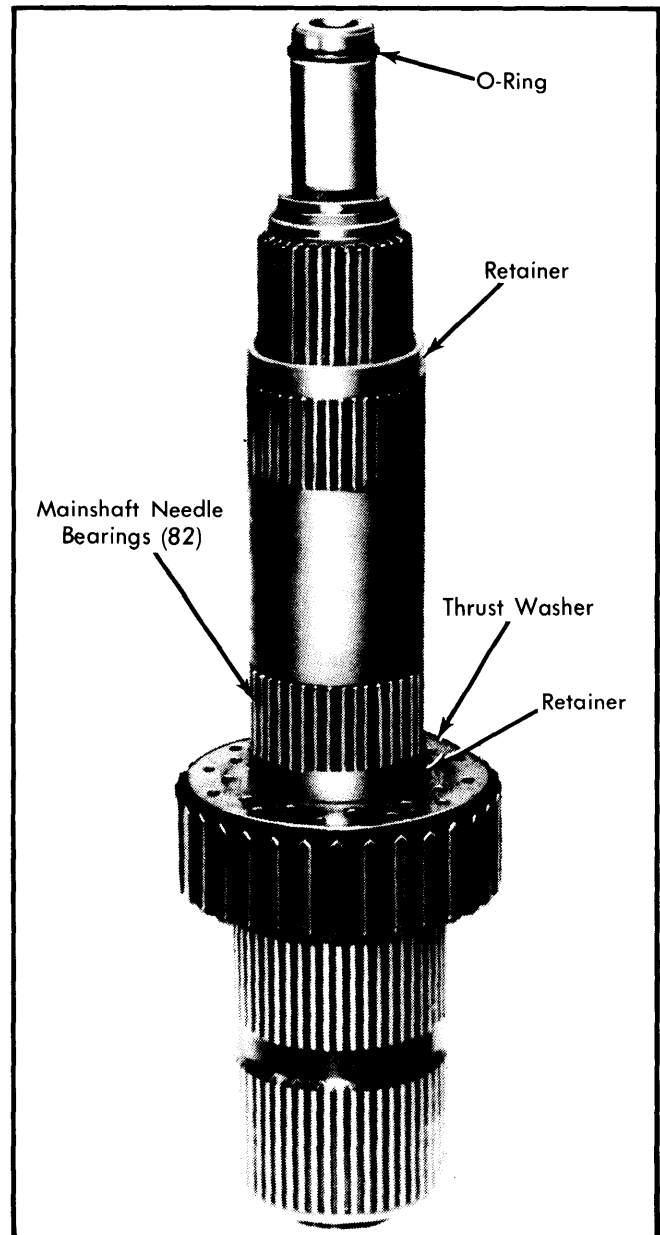

**Fig. 4** Mainshaft Needle Bearing and Spacer Installation

## AMERICAN MOTORS MODEL 119 (Cont.)

### REASSEMBLY

#### TRANSFER CASE

1) Install new input gear and front yoke oil seals using suitable tool (J-29162). Install new range sector "O" ring and retainer in case shaft bore. Install range sector, washers and lock nut on sector shaft. Install thrust bearing and race on input gear and install gear in front case. Install mainshaft thrust washer in input gear. Assemble range fork, rail and clutch sleeve. Install assembly in case. Be sure rail is seated in case bore. Install thrust washer and new "O" ring on shaft. See Fig. 4.

**NOTE** — The rail bore in the front case must be absolutely dry and free of oil. A small amount of oil in the bore will prevent the rail from seating completely and also prevent rear case installation.

2) Install needle bearings and bearing spacers on mainshaft. Coat shaft bearing surface and all needle bearings with petroleum jelly. Install short bearing spacer on shaft and install first 41 needle bearings. Install long bearing spacer, remaining 41 needle bearings and remaining short spacer. Be careful to avoid displacing bearings as spacers are installed. Use additional petroleum jelly to hold bearings in place if necessary.

3) Install spline gear on mainshaft. Take care to avoid displacing bearings while installing gear. Install sprocket carrier in drive sprocket and install sprocket carrier snap rings. Be sure to align carrier and sprocket according to reference marks made during disassembly.

**NOTE** — The sprocket carrier teeth are tapered on one side and the drive sprocket has a deep recess on one side. Be sure to assemble these components so the carrier tapered teeth and sprocket recess are on the same side.

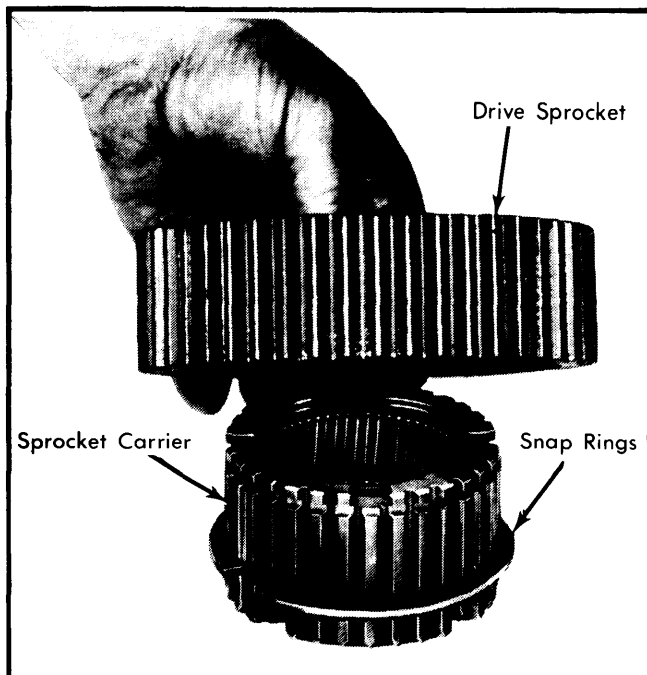

Fig. 5 Drive Sprocket and Sprocket Carrier

4) Install sprocket carrier bearings and spacers. Coat carrier bore and all 120 carrier needle bearings with petroleum jelly. Install center spacer. Install 60 bearings in each end of carrier and install remaining two spacers, one at each end of carrier. Use additional petroleum jelly to hold bearings in place if necessary. Install assembled sprocket carrier and drive sprocket on mainshaft. Do not displace mainshaft bearings during installation. Install clutch gear thrust washer in mainshaft. Position washer on sprocket carrier. See Fig. 6.

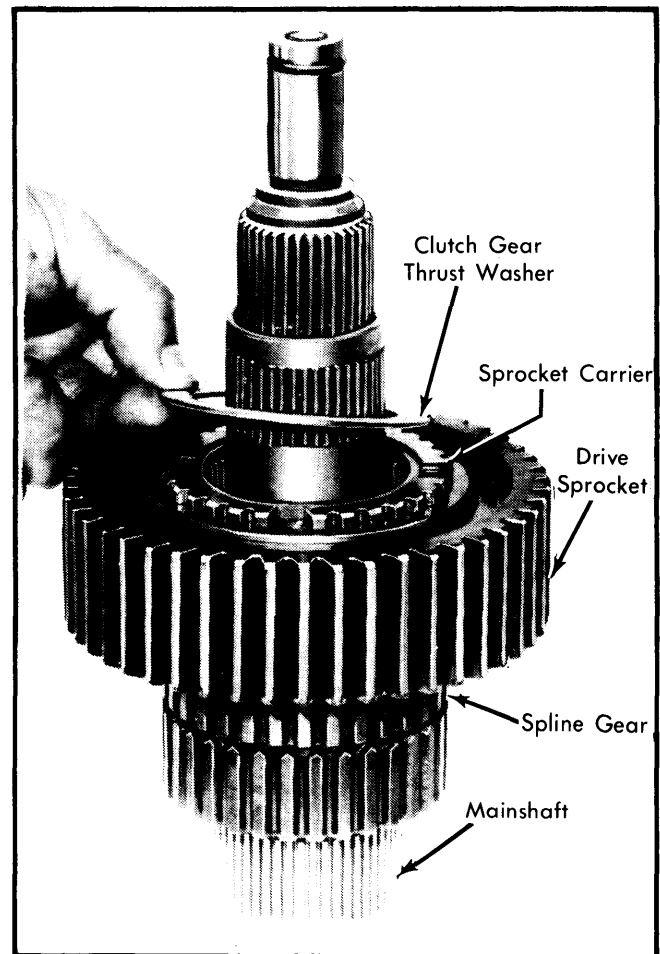

Fig. 6 Mainshaft Assembly

5) Install clutch gear on side gear. Be sure tapered edge of clutch gear faces side gear teeth. Install assembled side gear and clutch gear on mainshaft. Be sure gear is fully seated in sprocket carrier. Take care to avoid displacing any of the carrier or mainshaft needle bearings. Install mainshaft and gear assembly in case. Be sure mainshaft is fully seated on input gear. Install drive sprocket on front output shaft and install sprocket retaining snap ring. Install according to reference marks made during disassembly.

6) Install drive chain, front output shaft and drive sprocket. Raise and tilt driven sprocket and chain, install opposite end of chain on drive sprocket. Align front output shaft with shaft bore in front case and install shaft in case. Install front output shaft rear thrust bearing assembly on front output shaft. Install thin race first, then install bearing and thick race. Install viscous coupling on side gear and clutch gear.

**NOTE** — Clutch gear should be flush with coupling and gear teeth should not be visible.

## AMERICAN MOTORS MODEL 119 (Cont.)

7) Coat mainshaft pilot bearing surface and all 15 pilot roller bearings with petroleum jelly and install bearings on shaft. Install rear output shaft on mainshaft and into viscous coupling. Tap shaft with mallet to seat it if necessary. Install oil pump on rear output shaft, install new rear output bearing oil seal in rear case. Apply bead of sealer to mating surface of rear case, install rear case on front case.

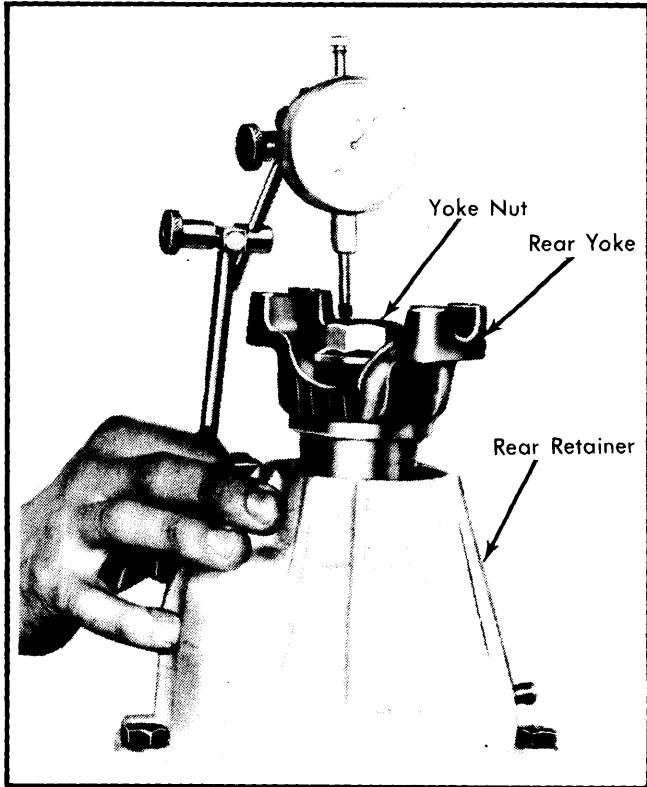

**Fig. 7** Checking Differential End Play.

**NOTE** — If rear case will not seat properly in the front case, check for the following: Oil in the range fork rail bore, front output shaft rear thrust bearing assembly is not aligned with the rear case, mainshaft is not completely seated, rear case not aligned with oil pump.

8) Install and tighten rear case-to-front case bolts. Install speedometer drive gear and differential shims on rear output shaft. Align rear retainer on rear case and install retainer. Install retainer bolts. Tighten bolts securely but not to specified torque. Install front and rear output shaft yokes and original yoke nuts. Tighten nuts finger tight only. Mount dial indicator on rear retainer and position indicator stylus so it contacts rear yoke nut. See Fig. 7.

9) Rotate front output shaft 10 to 12 complete revolutions and zero dial indicator. Rotate front shaft one more revolution and note dial indicator reading. End play should be .002-.010". If end play is incorrect, remove retainer, add or subtract differential shims as necessary to correct end play. After checking end play, remove front and rear yokes. Discard original yoke nuts. Remove rear retainer, apply bead of sealer to mating surfaces and reinstall retainer. Tighten to specifications.

10) Install front and rear yokes, install new yoke nut and seal. Tighten nut to specifications. Install detent ball, spring and bolt, tighten to specifications. Install drain plug and washer, fill transfer case with 4 pints of 10W-30 motor oil.

### LUBRICANT CHECKING PROCEDURE

**NOTE** — On transfer cases built after March 1980, do not attempt to check lubricant level until after allowing lubricant within rear retainer to drain back into case.

- 1) Raise vehicle. Check build date on identification tag. If transfer case was built before April 1980, proceed to step 3).
- 2) If transfer case was built after March 1980, lubricant level should be to bottom edge of filler plug.
- 3) Remove filler plug. Using a length of wire, measure distance from bottom edge of filler plug hole to lubricant level. Check chart below for proper level.

### FILLER PLUG LOCATION

The filler plug on this transfer case may be in any of 4 different locations. Because the plug may be located in different positions, there will be a different lubricant level for each position. See Fig. 8 for filler plug positions.

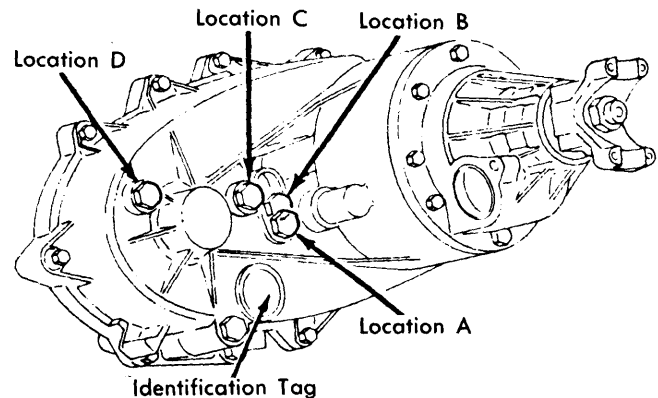

**Fig. 8** Filler Plug and Identification Tag Locations

### Transfer Case Lubricant Levels

Filler Hole Location	Distance From Edge of Hole to Specified Lubricant Level
A .....	0.56"
B .....	1.13"
C .....	1.20"
D .....	0.56"

### TIGHTENING SPECIFICATIONS

Application	Ft. Lbs.
Detent Retainer Bolt .....	23
Drain and Fill Plugs .....	18
Front and Rear Yoke Nuts .....	120
Indicator Switch .....	18
Operating Lever Lock Nut .....	18
Rear Case-to-Front Case Bolts .....	23
Rear Retainer Bolts .....	23