

Drive Axles

GENERAL MOTORS INTEGRAL HOUSING

**Buick
Cadillac
Chevrolet
Oldsmobile
Pontiac**

Axle Ratio Identification

DESCRIPTION

Semi-floating hypoid gear type with integral housing, with centerline of pinion set below centerline of ring gear. Differential is designed for use with an open drive line and coil or leaf springs. A removable steel cover, bolted to rear of housing, permits service of differential case without removing complete axle assembly from vehicle.

AXLE RATIO & IDENTIFICATION

Rear axle identification information is stamped on the forward side of left or right axle tube with the exception of Cadillac and Corvette. On Cadillac, 3 different locations are used, on vehicles with disc brakes, identification number is stamped on back side of right caliper support plate. On vehicles with drum brakes, identification number is stamped on right brake drum surface. An axle identification number is also stamped on right side of axle tube approximately 3" from differential housing. Corvette locates its identification number on the bottom surface of carrier at cover mounting flange.

BUICK

Axle Ratio	Conventional	Positive Traction
2.14:1	AK	BK
2.29:1	AH, AJ, RA	BH, BT
2.41:1	AJ, AZ, RB, GF, JA FA, JA	DJ, BZ, KA, LZ KA
2.73:1	AB, AX, RD, RX	BB, BX
2.93:1	HB, JC, YE, NA	KC, LX, YW
3.08:1	HG, JC, FB, ED, AC JD, YJ, NY	LW, KF, EW, KD LU
3.23:1	AU, JE, LF, JE	KE, LU

CADILLAC

Axle Ratio	Conventional	Positive Traction
2.28:1	UB	VS
2.41:1	UF	UY
2.56:1	UD, UY	
2.73:1	VE	VW
3.08:1	XJ	XY

CHEVROLET

Axle Ratio	Conventional	Positive Traction
2.29:1	RA, AH	BH
2.41:1	GF, LA, AJ, AZ, RB	LZ, BJ, BZ

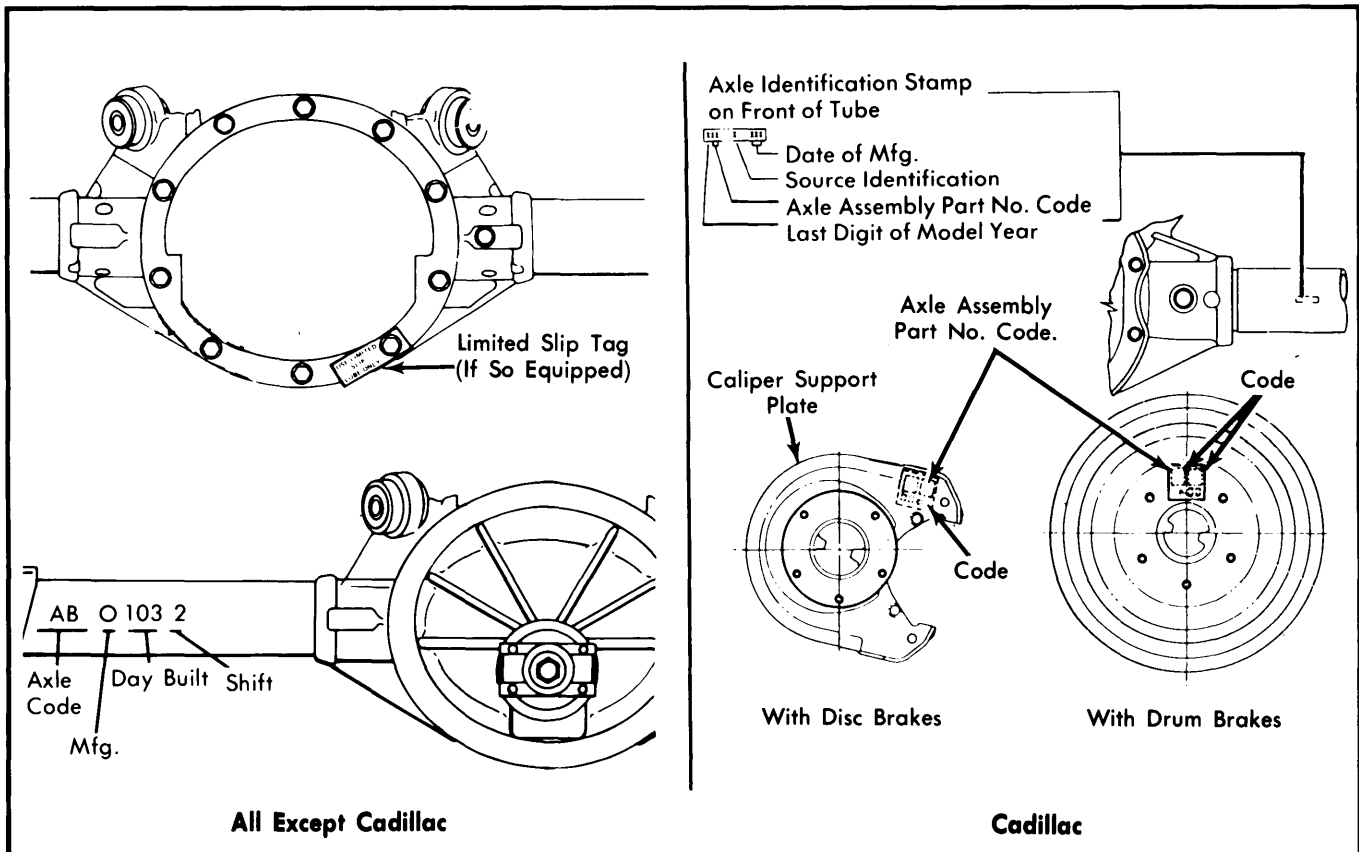

Fig. 1 Axle Ratio Code Locations

GENERAL MOTORS INTEGRAL HOUSING (Cont.)

Axle Ratio Identification (Cont.)

CHEVROLET (Cont.)

Axle Ratio	Conventional	Positive Traction
2.56:1	YD, AY, PH	YU, BY, PT
2.73:1	GB, YE, RD, AB, AX PA	YW, LX, BB, BX PU
3.08:1	YJ, LE, AC, AV PC	YY, LV, PW
3.42:1	PE, PY	

CHEVROLET CHEVETTE

Axle Ratio	Conventional	Positive Traction
3.70:1	QM, QK	

CHEVROLET MONZA

Axle Ratio	Conventional	Positive Traction
2.56:1	EB	EY
2.73:1	EC	EX
2.93:1	ED	EW

CHEVROLET CORVETTE

Axle Ratio	Positive Traction
3.07:1	Dana

Axle Ratio Identification (Cont.)

OLDSMOBILE

Axle Ratio	Conventional	Positive Traction
2.29:1	RA, AH, AT	BH, BT
2.41:1	AJ, BJ, AZ, GF, JA FA	BZ, LZ, KA
2.56:1	EB, GA, YD	EY, YU, LY
2.73:1	AB, AX, GB, LC, YE JC, EC	BB, BX, LX, YW KL, XE
2.93:1	AG, AW, ED	BG, BW, EW
3.08:1	AC, LE, JD	BC, LV, YY, YJ
3.23:1	AU, LF, EE, EU	BU, LU

PONTIAC

Axle Ratio	Conventional	Positive Traction
2.14:1	RH, AK	BK
2.29:1	RA, AH, AT, RT	BH, BT
2.41:1	AJ, AZ, RZ, YC, GF HF, PJ	PS, PV, BJ, BZ YT, LZ
2.56:1	AA, AY, YD, GA, HA PH, EB	BA, BY, YU, LY PY, EY
2.73:1	AB, RD, AX, YE, GB HB, PA, EC	BB, BX, YW, LX PU, EX
2.93:1	AG, ED	BG, EW
3.08:1	YJ, JD	PO, PW, PQ, YY, ED
3.23:1	AD, AU, PD, JB, LF	BD, BU, PX, LU, KE
3.42:1	PB	PU, PO

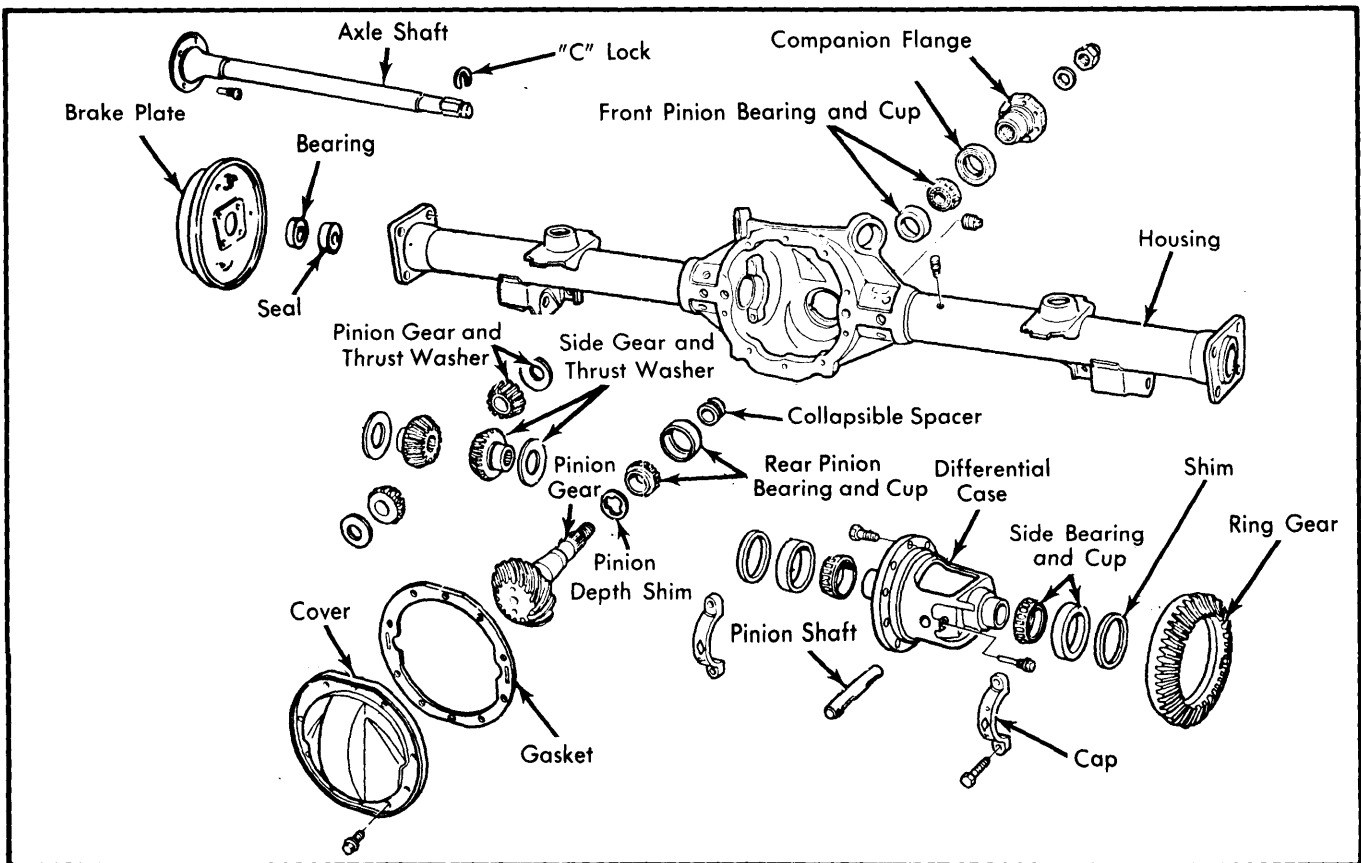

Fig. 2 Exploded View of General Motors Integral Rear Axle Assembly

GENERAL MOTORS INTEGRAL HOUSING (Cont.)

REMOVAL & INSTALLATION

CORVETTE WHEEL SPINDLE & SUPPORT

See *Corvette Rear* in *SUSPENSION* Section.

AXLE SHAFTS

Removal (Exc. Corvette) — Remove rear wheels and either brake drums or disc calipers and rotors. Drain lubricant from differential by removing cover. Remove pinion shaft lock screw and pinion shaft. Push axle shaft toward center of vehicle, remove "C" lock from bottom end of shaft, and carefully remove axle shaft from housing.

Installation — Reverse removal procedure and note the following: Axle shaft must be pushed outward after installing "C" lock to seat lock in counterbore of differential side gear.

Removal (Corvette) — 1) Disconnect inboard driveshaft trunion from side gear yoke. Bend bolt lock tabs down and remove bolts securing shaft flange to spindle drive flange.

2) Scribe mark on camber adjusting cam and on mounting bracket. Loosen camber adjusting nut and rotate cam so high point of cam points inboard. Remove driveshaft by withdrawing outboard end first.

Installation — Place driveshaft inboard trunion into side gear yokes and assemble "U" bolts. Rotate yokes so trunion seats are 90° apart. Install outboard drive flange into spindle drive flange pilot, position lock over bolt holes and install bolts. Tighten bolts and rebend lock tabs. Realign scribe mark on camber adjusting cam with mark on bracket and tighten bolts.

COMPANION FLANGE & OIL SEAL

Removal (All Models, Exc. Chevette & Corvette) — Raise vehicle, then remove propeller shaft, marking parts for reassembly reference. Using an INCH lb. torque wrench, measure and record pinion bearing preload by rotating pinion shaft through several revolutions. Mark companion

flange, nut and pinion shaft for reassembly reference, then remove nut using suitable tools. Remove washer, then use a suitable puller to remove flange. Pry oil seal out of housing using a screwdriver or hammer and chisel.

Installation — Pack seal lip cavity of new seal with lithium base extreme pressure lubricant, then install seal into housing until it seats against internal shoulder. Install companion flange, washer and nut, then tighten nut until all end play is removed. Continue tightening in small increments and checking preload until preload is 1-5 INCH lbs. more than recorded during disassembly. Install propeller shaft.

CAUTION — Do not exceed original preload by more than 5 INCH lbs.

Removal (Chevette) — 1) Raise vehicle, then disconnect propeller shaft from companion flange and remove shaft from transmission.

NOTE — As Chevette rear axle has an extension housing and an extension shaft coupled to front of axle housing, the companion flange is attached to forward end of extension shaft. Instead of companion flange, there is a drive coupling on end of pinion shaft. Axle housing oil seal contacts extension shaft instead of companion flange.

2) Place a floor stand under front of rear axle housing. Support extension housing and disconnect center support bracket from underbody. Remove bolts attaching extension housing to axle housing and separate them, using a screwdriver if necessary. Pry oil seal out of housing with a screwdriver.

Installation — Using tool (J-22922), drive oil seal into axle housing, making sure thrust washer is in place. Between extension shaft and pinion shaft, slide extension shaft over drive coupling and support front end with a floor stand. Install flange-to-axle housing bolts and connect center support bracket to underbody. Install propeller shaft, being sure thrust spring is in place. Remove floor stands and lower vehicle.

Removal (Corvette) — With wheels hanging freely, disconnect propeller shaft and remove. Disconnect axle drive shafts from carrier. Measure pinion bearing preload, then mark all parts for reassembly reference. Remove companion flange nut and washer, then drive flange off pinion using a brass drift and hammer. Pry oil seal out of carrier.

Installation — Pack cavity between seal lips of seal with lithium base extreme pressure lubricant, then install seal into carrier bore. Lubricate companion flange splines, then tap flange into place on pinion stem. Install washer and nut, then tighten nut until torque exceeds original preload by 1-5 INCH lbs.

CAUTION — Do not exceed original preload by more than 5 INCH lbs.

REAR AXLE ASSEMBLY

Removal (Buick) — 1) Raise vehicle and support at frame on both sides. Place floor jack under center of axle housing and lift it until it just starts to raise housing.

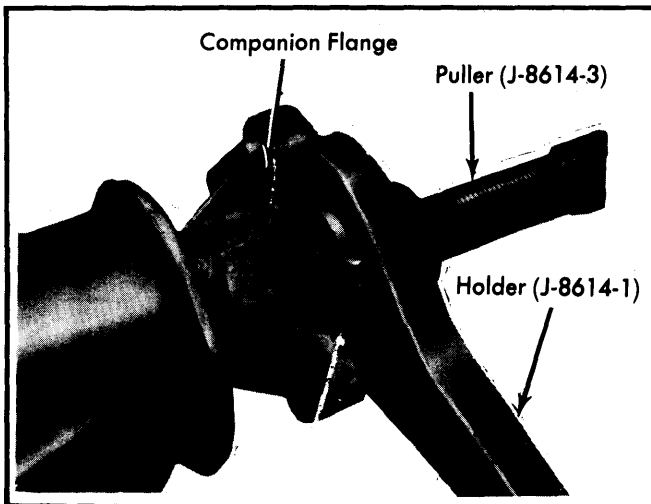

Fig. 3 Removal of Companion Flange

GENERAL MOTORS INTEGRAL HOUSING (Cont.)

2) On Skyhawk, disconnect torque arm and tie rod from axle housing. Disconnect rear universal joint from pinion flange, marking parts for reassembly reference. Disconnect parking brake cables at equalizer. Remove brake line junction block bolt at axle housing and disconnect brake lines at junction block. On Century and Regal, disconnect brake line at wheel cylinder.

3) Lower rear axle assembly and remove springs. Remove rear wheels and drums, remove rear axles. Disconnect lower control arms from axle housing and remove axle assembly.

Installation — To install, reverse removal procedure.

Removal (Cadillac) — 1) Raise vehicle on hoist and support axle with adjustable jack. Remove both shock absorbers from lower mounting. Disconnect upper and lower control arms at axle assembly.

2) Disconnect propeller shaft at flange. Remove brake hose at tee fitting on differential. Lower axle assembly, remove springs and axle assembly from vehicle.

Installation — To install, reverse removal procedure and note the following: On vehicles equipped with Electronic Level Control, inflate compressor assembly, lift height sensor level allowing air to enter shock absorbers. Release height sensor lever and reconnect to link.

Removal (Chevrolet, Exc. Corvette) — 1) Raise vehicle and support at frame on both sides. Place floor jack under center of axle housing and lift it until it just starts to raise housing.

2) On Monza, disconnect torque arm from differential. On Chevette, disconnect stabilizer bar, tie rod and rear axle extension bracket.

CAUTION — Support Chevette axle extension so it does not swing down rapidly when disconnected from body bracket.

3) Disconnect rear universal joint from pinion flange, marking parts for reassembly reference. Disconnect parking brake cables and, on all except Chevette, disconnect rear brake hose at floor pan. On Chevette, disconnect brake lines from clips on axle tubes, remove axle shafts and brake backing plates (with shoes and brake lines attached), and wire backing plates to frame.

4) Disconnect shock absorbers. On coil spring models, disconnect upper control arms from axle and remove lower control arm pivot bolts. On leaf spring models, remove lower spring plate attaching nuts, front and rear spring attaching bolts and springs. Lower axle assembly out of vehicle.

Installation — Reverse removal procedure and note the following: To install leaf springs, connect springs at front attachment and attach lower spring plates; then, attach springs at rear shackle.

Removal (Corvette) — Raise vehicle; then, remove exhaust system from behind catalytic converter. Disconnect strut rod bracket from underside of carrier and lower bracket with strut rods attached. Disconnect driveshafts at carrier yokes and remove carrier front mounting bracket bolt. Remove propeller shaft. Loosen spring-to-carrier bolts; then, remove cover bolts and allow lubricant to drain. Remove carrier from vehicle.

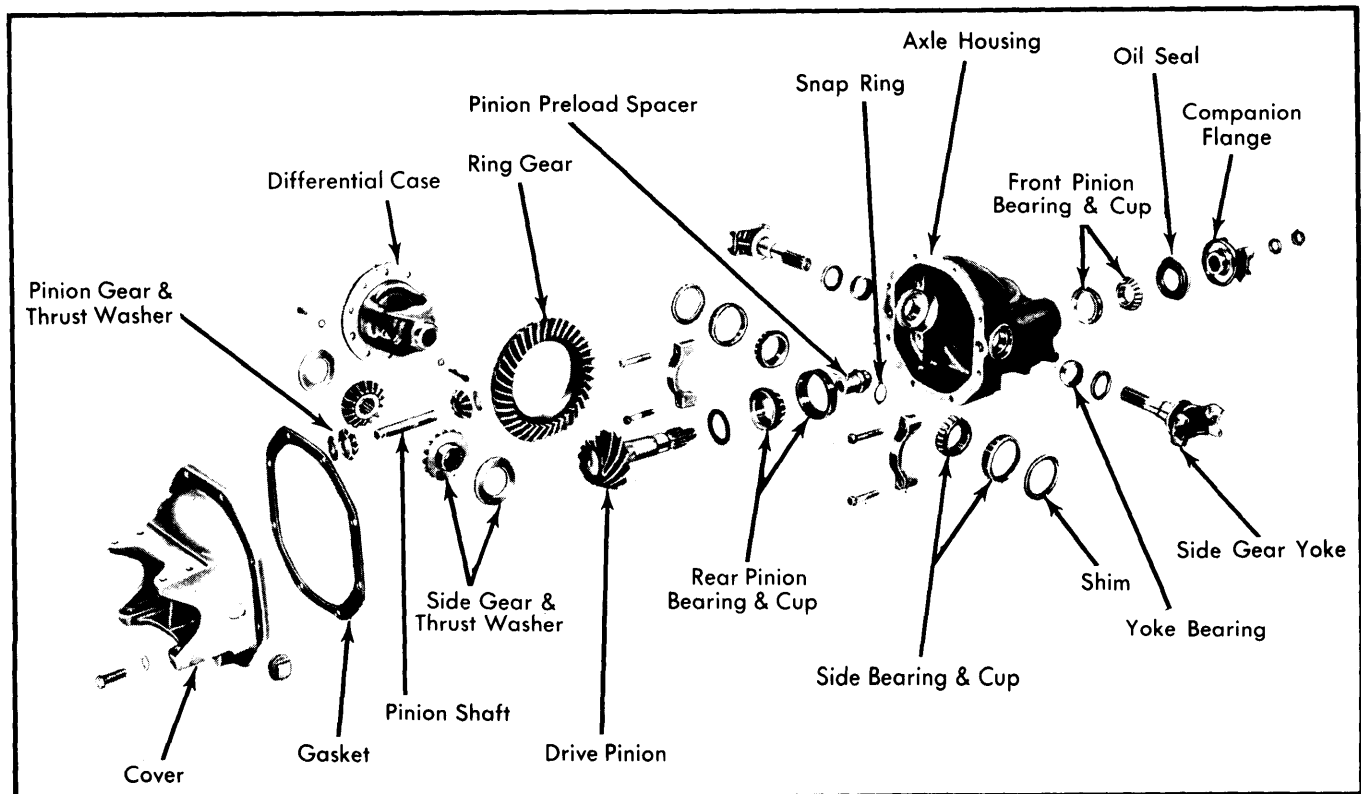

Fig. 4 Exploded View of Corvette Rear Axle Assembly

GENERAL MOTORS INTEGRAL HOUSING (Cont.)

Installation — 1) Insert two $\frac{1}{2}$ -13 x $1\frac{1}{4}$ " bolts (heads cut off and slotted at unthreaded ends) into two below-center carrier bolt holes, one on each side. Insert one $\frac{9}{16}$ -18 x $1\frac{1}{4}$ " bolt (head cut off and slotted at unthreaded end) into underside of carrier. These aligning studs aid in installation of carrier and strut rod bracket.

2) Install gasket and sealer to carrier and cover. Mount carrier to cover and install cover bolts; then, remove 2 aligning studs and install remaining cover bolts. Position strut rod bracket to carrier, install 3 bolts, remove aligning stud and install remaining bolt. Tighten spring to carrier bolts. Install propeller shaft, axle drive shafts and exhaust system.

Removal (Oldsmobile) — 1) Raise and support vehicle at frame. Mark propeller shaft at pinion flange. Disconnect and support propeller shaft at rear. Disconnect shock absorbers from axle.

2) Disconnect lower control arms, disconnect torque arm and tie rod on Starfire. Remove rear wheels, drums and axle shafts.

3) Disconnect parking brake cable at equalizer, then remove bolt from brake line junction block at axle housing. Disconnect brake lines from axle housing clips and wheel cylinders, then remove backing plates. Lower axle housing and remove springs.

Installation — To install, reverse removal procedure.

Removal (Pontiac) — 1) Raise and support vehicle at frame. Disconnect shock absorber at lower end. Mark rear universal joint and flange for proper reassembly; then, disconnect rear universal joint from flange. On Sunbird, disconnect upper control arm at differential end.

2) Disconnect parking brake cables at equalizer. Disconnect rear brake hose at floor pan. On coil spring vehicles, remove upper and lower control arm bolts at housing. For leaf spring equipped vehicles, remove spring plate attaching bolts and shackles. Remove assembly from beneath vehicle.

Installation — Reverse removal procedure and note the following: Control arm and shock absorber fasteners must be in normal load position while tightening.

OVERHAUL

DISASSEMBLY

Corvette — 1) Remove side gear yoke snap rings and remove yokes. Mark differential bearing caps and housing for reassembly reference; then, remove caps and differential case from housing. Remove side bearing shims and mark for reassembly reference.

2) Check pinion bearing preload. No preload reading and a loose pinion assembly indicate bearings are worn. Remove companion flange nut, flange and seal. Remove pinion shaft and rear bearing; then, remove front pinion bearing. Remove side gear yoke seals and yoke bearings from housing.

NOTE — For differential overhaul procedures, see *Positive Traction Differentials* in this section.

All Models (Exc. Corvette) — 1) Remove axle shafts. Check ring gear-to-pinion backlash and pinion bearing preload. This will indicate gear or bearing wear or an error in backlash or preload setting. Mark differential bearing caps and housing for reassembly reference. Remove caps and pry differential case from housing. Remove cups and shims and keep with bearing caps for reassembly reference.

2) Remove differential pinion shaft, gears, and side gears with thrust washers keeping them in order for reassembly. Remove ring gear bolts (*Left Hand Threads*) and tap gear from case using soft drift and hammer.

NOTE — For positive traction differential overhaul procedures, see *Positive Traction Differentials* in this section.

3) Remove pinion nut and companion flange (drive coupling on Chevette), then remove pinion shaft and front bearing. If necessary, remove pinion bearing cups from housing using a brass drift. Press pinion shaft out of rear bearing and note thickness of pinion depth shim pack.

REASSEMBLY

Pinion Depth Adjustment — 1) Drive pinion rear bearing shim thickness, controlling pinion depth of mesh with ring gear, must be determined whenever a new axle housing, ring and pinion set, or pinion bearings and races are installed. Depth of mesh is determined by using suitable Pinion Setting Gauge tool set.

NOTE — Checking procedure for different axles is the same; however, tool component combinations vary between axles. See Fig. 6 and Tool Application Tables for tool numbers and location of components used.

2) If removed, install pinion bearing races, then install lubricated pinion bearings. Position gauge plate and rear pinion bearing pilot (if used) on preload stud, then install through rear pinion bearing and through front pinion bearing and front pinion bearing pilot. Install hex nut until snug, then rotate bearings to insure proper seating. Hold preload stud stationary with a wrench on flats, then tighten hex nut until 20 INCH lbs. are required to rotate bearings.

3) Mount side bearing gauging discs on ends of arbor, then place arbor into carrier making sure discs are properly seated. Install side bearing caps and bolts, then tighten bolts to avoid movement. Position dial indicator on mounting post of arbor, with contact button resting on top surface of plunger. Preload dial indicator one-half revolution, then tighten in this position.

4) Place plunger onto gauging area of gauge plate. Rock plunger rod slowly back and forth across gauging area until dial indicator reads greatest deflection, then set indicator to zero. Repeat rocking action several times to verify setting. Once zero reading is obtained, swing plunger until it is removed from gauging area. Dial indicator will now read required pinion shim thickness for a "nominal pinion". Record this reading.

GENERAL MOTORS INTEGRAL HOUSING (Cont.)

Tool Location Tool Part Number

Chevrolet Chevette

①	J-21777-43
②	Not Used
③	J-23597-21
④	J-23597-20
⑤	J-23597-6
⑥	J-23597-4

Oldsmobile 7 1/2" Ring Gear

①	J-21777-43
②	J-21777-12 (Starfire) J-21777-40 (Exc. Starfire)
③	J-21777-42
④	J-23597-11
⑤	J-23597-1
⑥	J-21777-45

Oldsmobile 8 1/2" & 8 3/4" Ring Gear

①	J-21777-43
②	J-21777-35
③	J-21777-42
④	J-21777-21 (8 1/2") J-21777-2 (8 3/4")
⑤	J-21777-1
⑥	J-8619-10 (8 1/2") J-21777-3 (8 3/4")

Pontiac 7 1/2" Ring Gear

①	J-21777-43
②	J-23597-12 (Sunbird) J-21777-40 (Exc. Sunbird)
③	J-8619-12
④	J-23597-11
⑤	J-23597-1
⑥	J-21777-45

Pontiac 8 1/2" & 8 3/4" Ring Gear

①	J-8619-13
②	J-21777-35
③	J-8619-12
④	J-21777-29
⑤	J-21777-1
⑥	J-8619-10

Pinion Installation & Preload Adjustment — Install a new collapsible spacer over pinion stem, then position pinion in housing. While holding pinion forward, carefully drive front pinion bearing onto pinion shaft until a few threads are exposed. Install new oil seal, then drive coupling (Chevette) or companion flange (All Others), washer and nut, and tighten until end play is removed. Rotate pinion several times to seat bearings, then check preload using an INCH lb. torque wrench. Continue tightening nut and checking preload until proper preload is obtained (see specifications).

CAUTION — Do not back off nut to lessen preload. If preload is exceeded, a new collapsible spacer must be installed and nut retightened until proper preload is obtained.

Case Reassembly — Place ring gear onto case, install new bolts, then alternately tighten bolts to pull ring gear into position on case. Place side gear thrust washers over side gear

hubs, then install assemblies into case in their original position. Install pinions and thrust washers into case, then install pinion shaft and lock bolt. Using suitable installing tools, install side bearings onto differential case.

NOTE — For positive traction differential overhaul procedures, see *Positive Traction Differentials* in this section.

Side Gear Yoke Bearings and Seals (Corvette) — Using suitable tool (J-9773), drive bearing into carrier bore until fully seated. Install new seal in bore outboard of bearing.

NOTE — Side bearing preload adjustment is to be made before pinion is installed. If pinion is installed, remove ring gear from case.

Side Bearing Preload (All Exc. Corvette) — 1) Measure thickness of original side bearing preload shims. Then, select a service spacer (.160" for 6 1/2" and 7 1/2" ring gear, .170" for 8 1/2" and 8 3/4" ring gear) and service shims with a total thickness slightly less than the original shims. Install differential case in housing. Install service spacer between each bearing cup and housing with chamfered edge of spacer against housing. Install left bearing cap loosely so that differential case is free to move.

2) With left bearing race and spacer against housing, install both right and left service shims previously selected between right bearing race and service spacer. Insert progressively larger feeler gauges between right shim and service spacer until a noticeable drag is felt.

3) Remove carrier and install ring gear (if removed). Select two shims with a total thickness equal to that of service shims and feeler gauge and reinstall with carrier (equal thickness on each side of carrier). Adjust differential backlash, then preload differential bearings by replacing both shims with shims .004" (.008" total) thicker.

NOTE — Do not attempt to reinstall the original production shims as they will break when tapped into place. Previously installed SERVICE shims may be re-used.

Side Bearing Preload (Corvette) — 1) Install differential assembly in housing with ring gear firmly against pinion. Insert suitable gauging tool (J-22779) between left bearing cup and carrier housing. While oscillating tool, turn adjusting nut clockwise until a noticeable drag is felt. Tighten tool lock bolt and remove tool.

2) Measure thickness of gauging tool in a minimum of 3 places, average readings and record result. Turn ring gear 90°, repeat measuring procedure and remeasure tool thickness.

3) To determine required thickness of service shim, subtract thickness of service spacer from the **higher** of the 2 averaged readings obtained in step 2). Install proper shim between service spacer and bearing, install left bearing cap and tighten bolts.

4) Remove right bearing cap and perform measuring procedure as given in steps 1) and 2). Required thickness of service shim is determined as in step 3), but an additional .008" must be added to service shim size to obtain proper preload.

GENERAL MOTORS INTEGRAL HOUSING (Cont.)

NOTE — Do not attempt to reinstall the original production shims as they will break when tapped into place. Previously installed SERVICE shims may be re-used.

5) Install proper shim between service spacer and bearing, install left bearing cap and tighten bolts.

Ring Gear & Pinion Backlash — Check backlash with a dial indicator mounted to axle housing at four locations around ring gear. Variation should not exceed .002". If backlash is not correct (see specifications), adjust side bearing shims as necessary. After all adjustments have been completed, tighten all bolts, then make a tooth contact pattern check to insure correct assembly.

ADJUSTMENT SPECIFICATIONS

Application	Specification
Pinion Bearing Preload ^①	
Buick (Exc. Skyhawk), Pontiac (Exc. Sunbird)	
New Bearings	20-25 INCH Lbs.
Used Bearings	10-15 INCH Lbs.
Cadillac	
New Bearings	24-32 INCH Lbs.
Used Bearings	12-18 INCH Lbs.
Chevrolet (Exc. Chevette, Corvette, Monza)	
New Bearings	15-30 INCH Lbs.
Used Bearings	10-15 INCH Lbs.
Corvette	
New Bearings	20-25 INCH Lbs.
Used Bearings	5-10 INCH Lbs.
Chevette	
New Bearings	15-25 INCH Lbs.
Used Bearings	5-10 INCH Lbs.
Oldsmobile	
New Bearings	24-32 INCH Lbs.
Used Bearings	8-12 INCH Lbs.
Monza, Skyhawk, Skylark, Sunbird	
New Bearings	10-25 INCH Lbs.
Used Bearings	8-12 INCH Lbs.
Side Bearing Preload	
All Models	② Slip Fit Plus .008"
Ring Gear Backlash	
Buick, Pontiac	.006-.008"
Cadillac	.005-.009"
Chevrolet	.005-.008"
Oldsmobile	.005-.009"

① — Measured with new seal without ring gear installed.

② — Add .004" to each side to preload bearings (exc. Corvette). For Corvette: Add .008" to right side only.

TIGHTENING SPECIFICATIONS

Application	Ft. Lbs.
Ring Gear-to-Case Bolt	
Buick	80
Corvette	60
Cadillac, Chevrolet, Oldsmobile	90
Chevette	48
Monza	50
Pontiac	80
Bearing Cap Bolt	
Buick, Chevrolet, Pontiac	60
Cadillac	65
Chevette, Corvette, Monza, Oldsmobile	55
Pinion Shaft Lock Bolt	
Buick, Chevette	12
Cadillac, Corvette, Oldsmobile	20
Chevrolet	25
Monza	150 INCH lbs.
Pontiac	15
Housing Cover Bolts	
Buick, Cadillac, Pontiac	30
Chevette	22
Chevrolet	25
Corvette	50
Monza, Oldsmobile	20
Universal Joint Flange-to-Pinion Flange	
Buick, Pontiac	15
Cadillac, Chevrolet	70
Corvette	75
Oldsmobile	16
Corvette Axle Drive Shafts	
To Spindle	75
To Yoke	15
Universal Joint Flange-to-Companion Flange	
Chevette	16