

## 173" V6

### IDENTIFICATION CODING

#### ENGINE IDENTIFICATION

Engines are identified by a number code, the fifth digit of the Vehicle Identification Number, located inside the windshield on left upper side of instrument panel. Number code also appears as part of a production or unit number stamped on the front of the engine block, below the right cylinder head. Code number is also found on code number tape on front and rear of left rocker cover.

Application	VIN Code
173" (2.8 Liter) 2-Bbl. V6 .....	7

#### ENGINE REMOVAL

See Engine Removal at end of ENGINE Section.

### CYLINDER HEADS & MANIFOLDS

#### INTAKE MANIFOLD

**Removal** — 1) Disconnect battery, remove air cleaner and drain cooling system. Disconnect upper radiator hose, heater hose and accelerator linkage and springs from manifold. Remove throttle valve linkage from carburetor if equipped with automatic transmission. Remove cruise control diaphragm actuator mounting bracket (if equipped).

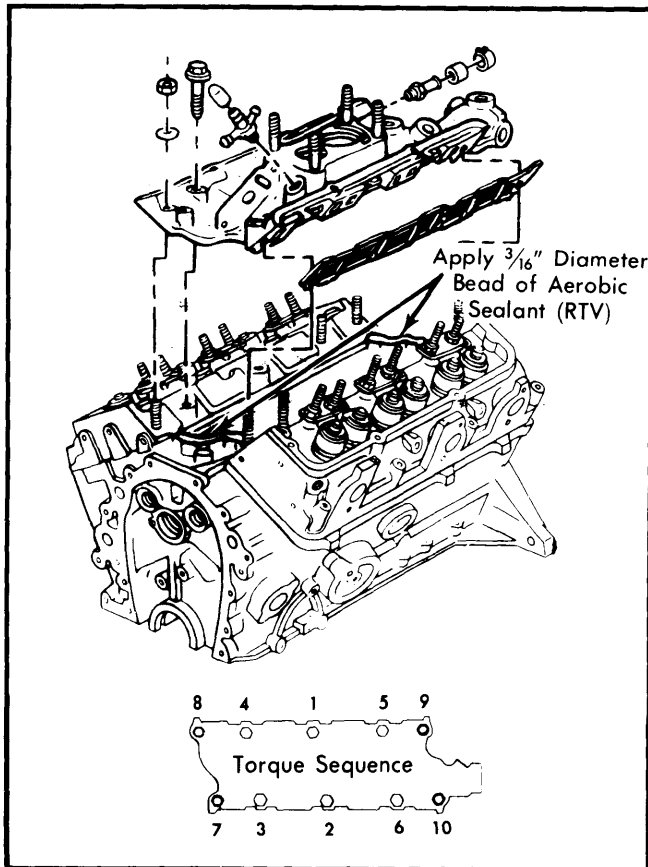

Fig. 1 Intake Manifold Installation

2) Remove vacuum and fuel hoses from manifold. Remove EFE pipe from rear of manifold. Remove power brake vacuum pipe and bracket. Disconnect manifold wiring harness and remove spark plug wires and distributor cap. Mark position of rotor and remove distributor. Remove front engine strut at radiator support and at engine bracket. Remove engine strut bracket. Remove carburetor and rocker covers. Remove intake manifold.

**Installation** — Apply a 3/16" bead of RTV sealer or equivalent on front and rear ridges of block. Install new gaskets on cylinder heads and extend RTV bead 1/4" onto gasket ends to hold them in place. Install intake manifold and check area between ridges and manifold for complete seal. Install bolts and nuts and tighten in sequence. See Fig. 1. To complete installation, reverse removal procedure.

**NOTE** — When installing intake gaskets, notice that the gaskets are marked Right Side and Left Side. The new intake gaskets will have to be cut to install behind push rods. See Fig. 2.

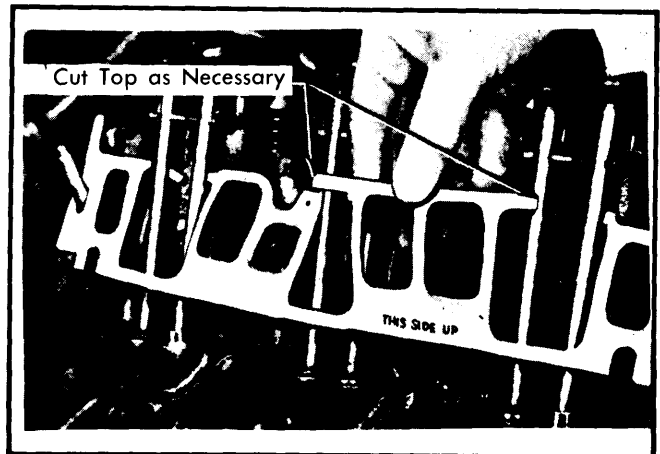

Fig. 2 Intake Manifold Gasket Installation

#### CYLINDER HEADS

**Removal** — Remove intake manifold. Disconnect exhaust pipe from exhaust manifold flanges. Remove heat stove pipe, from the left side exhaust manifold, and the pulse air injection reaction (PAIR) manifolds from both exhaust manifolds. Remove exhaust manifolds. Remove alternator, bracket and stud. Remove dipstick tube and bracket from left head. Loosen rocker arms to remove push rods. Remove head bolts, cylinder heads and gaskets.

**NOTE** — To remove right exhaust pipe from manifold at flange, it is necessary to break bolts out of manifold. To do this, tighten flange bolt upper nuts, as indicated in Fig. 3, until bolts break.

**Installation** — 1) Clean all mating surfaces and install gaskets over dowel pins. Install cylinder heads, apply sealing compound to head bolts and gradually tighten, in sequence, to specified torque. See Fig. 4.

## 173" V6 (Cont.)

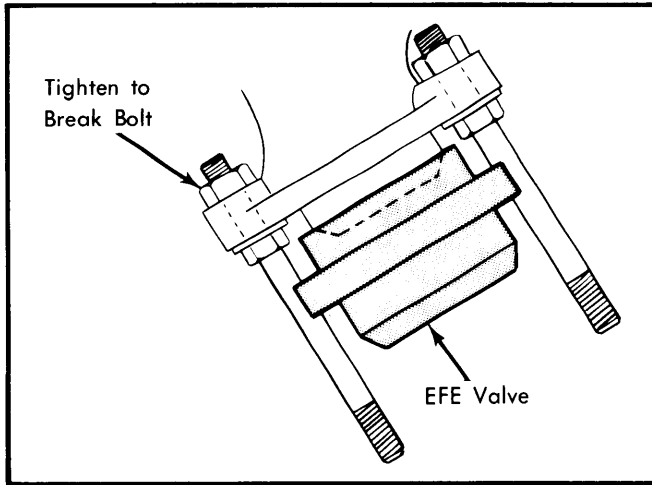

**Fig. 3 Exhaust Manifold Flange Bolts (Right Side Only)**

2) Install intake and exhaust manifolds. Install push rods and adjust valves. Reverse removal procedure to complete installation.

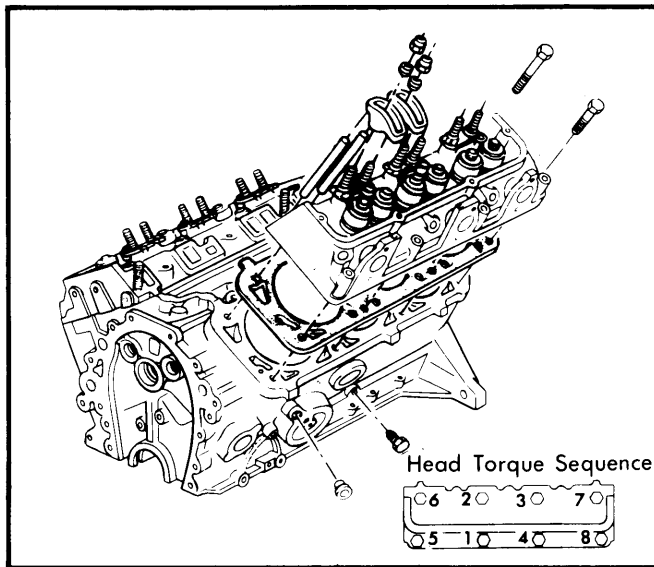

**Fig. 4 Cylinder Head Installation**

## VALVES

### VALVE GUIDE SERVICING

If valve guide stem-to-guide clearance exceeds specifications, ream valve guide to next oversize. Valves are available with .0035" (.089 mm), .0155" (.394 mm) and .0305" (.775 mm) oversize stems.

### VALVE STEM OIL SEALS

"O" ring type is used on all valves. Installed on lower groove of valve stem. A light coat of oil on stem will help prevent twisting of the oil seal. See *Valve Spring Removal* for service instructions.

## VALVE SPRINGS

**Removal** — Remove rocker arm cover, spark plug, rocker arm and push rod on cylinder(s) to be serviced. Install air line adapter (J-23590) to spark plug port and apply compressed air to hold valves in place. Using a suitable tool (J-5892), compress valve spring and remove valve locks, cap, oil shedder, valve spring and damper. Remove and discard oil seal. See Fig. 5.

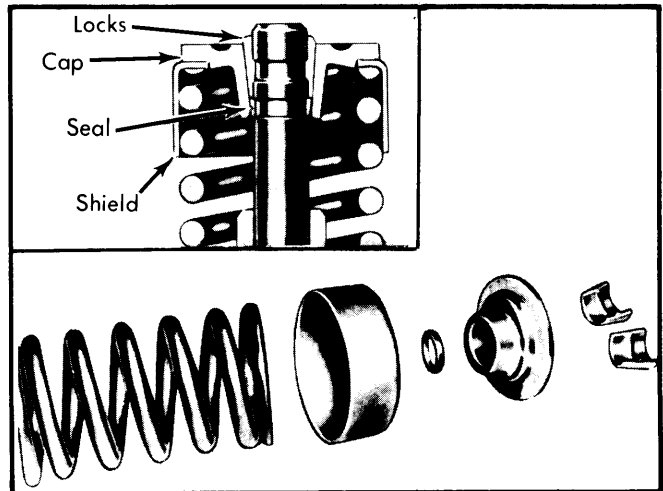
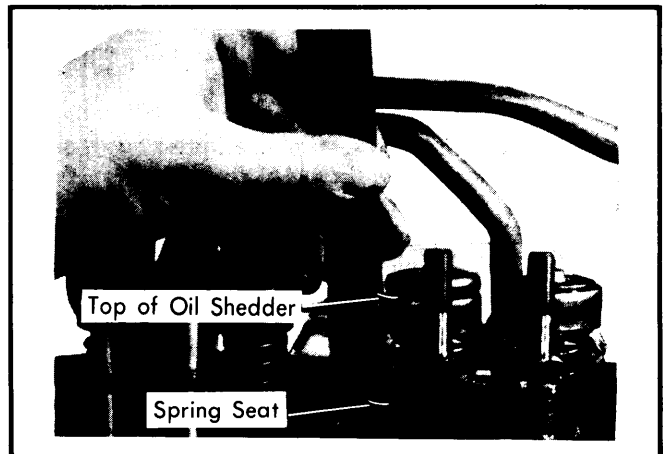

**Fig. 5 Upper Valve Train Components**

**Installation** — Before reinstalling old springs, check with a suitable spring tester. Springs should be replaced if not within 10 lbs. of specified load. Set the valve spring and damper, oil shedder and valve cap in place. Compress spring and install oil seal in lower groove of stem (ensure that seal is flat and not twisted). Install valve locks and release compressor tool. Check that valve locks are properly seated in upper groove of valve stem.

### VALVE SPRING INSTALLED HEIGHT

Installed height of valve spring should be 1.575" (40 mm). Measure from top of spring seat in head to top of oil shedder. If measurement exceeds specifications, install .063" (1.6 mm) shim at spring seat. Do not shim to obtain height under minimum specifications. See Fig. 6.



**Fig. 6 Checking Valve Spring Installed Height**

## 173" V6 (Cont.)

## VALVE ADJUSTMENT

Adjust valves with lifters on base circle of camshaft lobe as follows:

- 1) Set engine at No. 1 cylinder firing position. Adjust intake valves on cylinders 1, 5 and 6. Adjust exhaust valves on cylinders 1, 2 and 3.
- 2) Adjust valves by backing off adjusting nut until lash is felt at push rod. Then tighten until all lash is removed. Tighten nut  $1\frac{1}{2}$  additional turns. See Fig. 7.
- 3) Set engine at No. 4 firing position. Follow the procedure in step 2), adjust intake valves on cylinders 2, 3 and 4. Adjust exhaust valves on cylinders 4, 5 and 6. Install distributor cap and rocker covers and adjust idle speed.

## ROCKER ARM STUDS

Cylinder heads use threaded rocker arm studs. Rocker arm studs that have damaged threads should be replaced with new studs. If threads in the head are damaged or stripped, the head can be retapped, and a helical type insert installed. If a helical insert is not available, replace cylinder head.

## HYDRAULIC VALVE LIFTER ASSEMBLY

If hydraulic valve lifters are being removed, mark or identify lifters to ensure that they are installed in original position. Lifters are serviced as complete assemblies only. If lifter is damaged or worn, complete lifter must be replaced. If lifters are disassembled for cleaning and inspection, after reassembly they should be tested using a suitable leakdown rate tester.

**NOTE** — Some engines will have both standard and .010" oversize valve lifters. The cylinder block will be marked, where the oversize lifters are used, with a daub of white paint and 0.25 (mm) O.S. stamped on the lifter boss. See Fig. 8.

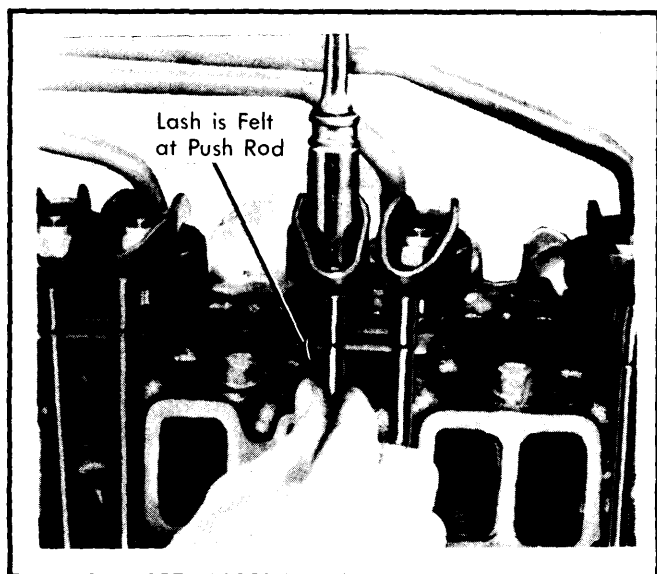

Fig. 7 Adjusting Valve Lash

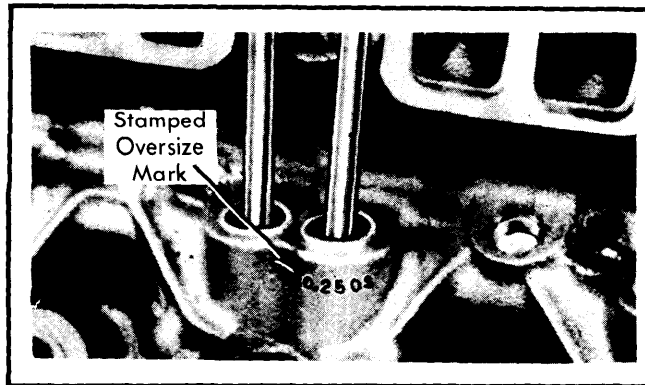

Fig. 8 Oversize Lifter Marking

## PISTONS, PINS &amp; RINGS

## OIL PAN

See *Oil Pan Removal at end of ENGINE Section.*

## PISTON &amp; ROD ASSEMBLY

With oil pan, oil pump and cylinder heads removed, place piston at bottom of stroke and cover with a cloth to catch cuttings. Use a suitable ridge reamer to remove any ridge or deposits from upper portion of the cylinder bore. Be sure piston and rod assemblies are marked for installation in their original locations.

**Removal** — With piston at bottom of stroke, remove connecting rod caps and install suitable guides over rod bolts. Push piston and rod out top of bore. Reinstall caps to their respective connecting rods. If necessary, rotate crankshaft to remove remaining caps.

**Installation** — 1) Apply a light coat of engine oil to pistons, rings and cylinder bores. Use suitable compression tool to compress rings during installation. Make sure ring gaps are staggered around piston and are not aligned.

2) Install piston and rod assembly with rod bearing tang slot on opposite side from camshaft.

3) Remove guides from rod bolts and install bearings and caps and tighten.

## FITTING PISTONS

Measure cylinder bore diameter with an inside micrometer or a dial bore gauge. With rod and pin removed, measure piston on skirt at right angles to piston pin at centerline of pin. Maximum allowable clearance for a used piston is .0027". Maximum allowable clearance for a new piston is .002".

## PISTON PINS

Using a suitable piston pin tool (J-24086-20) and adapters, remove pin. With piston and rod separated, inspect pin and pin bore for wear and measure clearance. Pin bore in rod is press fit. If pin bore in piston exceeds .00036" clearance, replace piston and pin as an assembly.

## 173" V6 (Cont.)

### CRANKSHAFT & ROD BEARINGS

#### MAIN & CONNECTING ROD BEARINGS

**NOTE** — Precision bearings are used in this engine and shimming is not acceptable for adjustment. Never file or grind connecting rods or caps when fitting bearings.

**Connecting Rod Bearings** — Remove rod cap and use Plastigage method to check bearing clearance. Bearings must be replaced if they are not within specifications. New bearings are available in standard, .0005" (.013 mm) and .001" (.026 mm) undersize for use with a standard size crankshaft. When all bearings are checked and/or replaced and then rechecked, tap each rod lightly (parallel to crankpin). Rod clearance, checked between rod cap and crank throw, should be .006-.017".

**NOTE** — If clearance cannot be brought within specifications with service bearings, grind crankpin(s) to next undersize. If already ground to maximum undersize, replace crankshaft.

**Main Bearings** — 1) Support crankshaft at both front and rear (damper and flywheel) and ensure that all bearing caps, other than the one being checked, are tight. Starting with rear main bearing cap and working forward, remove one cap at a time and check bearing clearance using Plastigage method.

**NOTE** — When checking No. 1 main bearing, remove all accessory drive belts to prevent a tapered distortion of the Plastigage.

2) If clearances are not within specifications, new bearings are available in standard, .0006" and .0013" undersize. Always replace upper and lower inserts as a unit.

3) Remove all main bearing upper halves (except rear main) by inserting a suitable tool in crankshaft oil hole. Rotate crankshaft in a clockwise direction to roll bearing from engine block. Oil new upper bearing half and insert plain (unnotched) end between crankshaft and indented (notched) side of block. Rotate crankshaft counter-clockwise to roll bearing into place.

4) To replace rear main bearing upper half, use a small brass drift and a hammer to start bearing rotating out of block. Take care not to nick crankshaft journal. Use a pair of pliers (with taped jaws) to hold bearing thrust surface to oil slinger and rotate crankshaft to remove bearing. Oil new bearing and insert plain (unnotched) end between crankshaft and indented (notched) side of block. Use pliers, as in removing, to rotate bearing into place.

**NOTE** — If a main bearing cap requires replacement, laminated shims are available. Shim requirement will be determined by bearing clearance.

5) Main bearing caps are to be installed with arrows pointing forward. Torque main bearing cap bolts, except No. 3 main cap, to 70 ft.lbs. Torque No. 3 main bearing cap to 11 ft. lbs. and tap end of crankshaft toward the rear and then toward the front to line up main bearing with crankshaft thrust face. Retorque all main bearing cap bolts. Rotate crankshaft to ensure that there is no excessive drag. Measure end play at front end of No. 3 main bearing. End play should be .002-.008".

#### REAR MAIN BEARING OIL SEAL

**NOTE** — Upper rear main bearing oil seal is serviced through repair, rather than replacement. Lower rear main bearing oil seal should be replaced at time of repair to upper seal.

**Repair** — 1) Remove oil pan, oil pump and rear main bearing cap. Use a suitable packing tool (J-29114-2) and drive upper oil seal into groove on both sides, approximately 1/4".

2) Measure the amount the seal was driven in on one side and add 1/16" to this amount. Cut this length from the old lower seal. Repeat this for the other side.

3) Place the piece of cut seal into the groove of a suitable seal installer guide (J-29114-1) and install the guide onto the block. Using the packing tool, drive the seal into the block. Drive until the packing tool reaches its machined stop. Repeat for opposite side.

4) Install new seal into rear main bearing cap. Use Plastigage to check clearance. If out of specifications, recheck seal ends for fraying or anything between cap-to-block interface preventing proper seating of cap. Apply anaerobic sealant to cap interface. Install cap and tighten bolts. Install oil pump and oil pan.

### CAMSHAFT

#### FRONT ENGINE COVER

**Removal** — Disconnect negative battery cable. Remove accessory drive belts and drain cooling system. Remove water pump. Remove A/C compressor and bracket. Use suitable torsional damper tool (J-23523) and remove damper. Disconnect lower radiator hose at front cover and heater hose at water pump connection. Remove front cover. See Fig. 9.

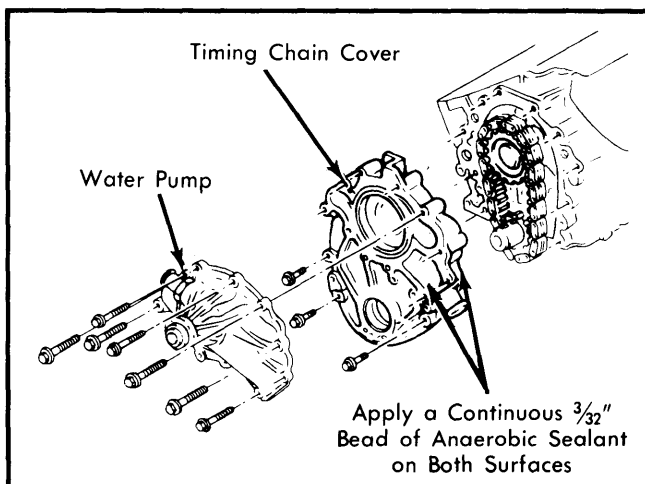

Fig. 9 Water Pump & Front Cover

**Installation** — Clean sealing surfaces thoroughly. Apply a continuous 3/32" bead of anaerobic sealant to front cover sealing surfaces. See Fig. 10. Place front cover on engine and install water pump using pipe sealer on bolt threads. Install remaining bolts and tighten. Reverse removal procedure to complete operation.

## 173" V6 (Cont.)

**NOTE** — If removing water pump without front cover, it is necessary to use special tool J-29176 (or equivalent) to hold front cover in place. Any movement of front cover at this time may cause internal or external water leaks at cover to block sealing surface. See Fig. 11.

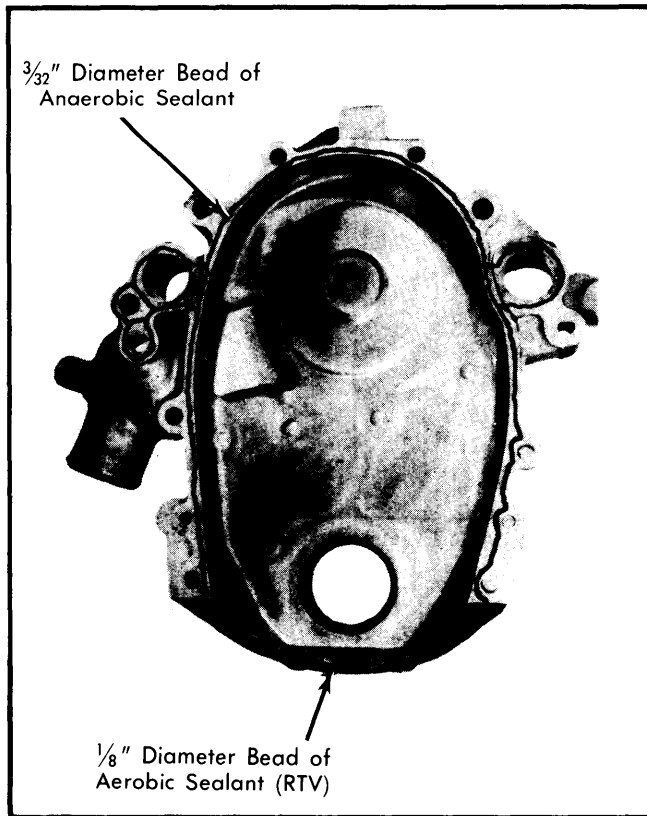

Fig. 10 Front Cover Sealant Placement

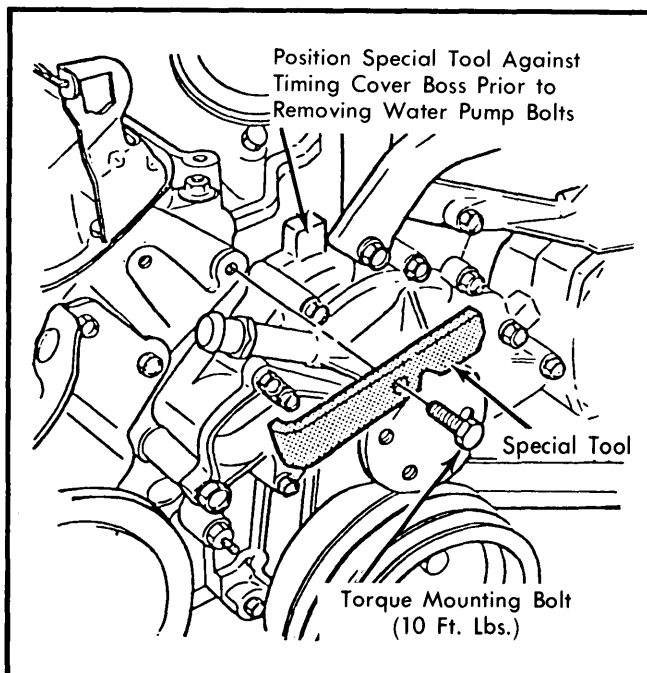

Fig. 11 Installing Special Tool for Water Pump

## FRONT COVER OIL SEAL

**Removal** — The oil seal may be replaced without removing front cover. Remove torsional damper and pry seal outward. Use caution when removing seal so crankshaft is not damaged.

**Installation** — Install new seal with open side toward inside of front cover. Use a suitable seal aligner and installing tool (J-23042) to drive seal into position.

## TIMING CHAIN

**Removal** — Remove front cover and rotate engine to align timing marks on crankshaft and camshaft sprockets (No. 4 firing). Remove camshaft sprocket-to-camshaft bolts. Remove sprocket and timing chain together. See Fig. 12.

**NOTE** — Sprocket is light press fit on camshaft, dislodge by tapping lightly on lower edge of sprocket with a plastic mallet.

**Installation** — 1) Place timing chain over camshaft sprocket so that it hangs below sprocket. Align marks on camshaft and crankshaft sprockets. See Fig. 12.

2) Align dowel in camshaft with dowel hole in camshaft sprocket. Install sprocket on camshaft. Use mounting bolts to draw sprocket onto camshaft and tighten bolts. Check sprocket alignment, lubricate chain, with engine oil and install other components as previously described.

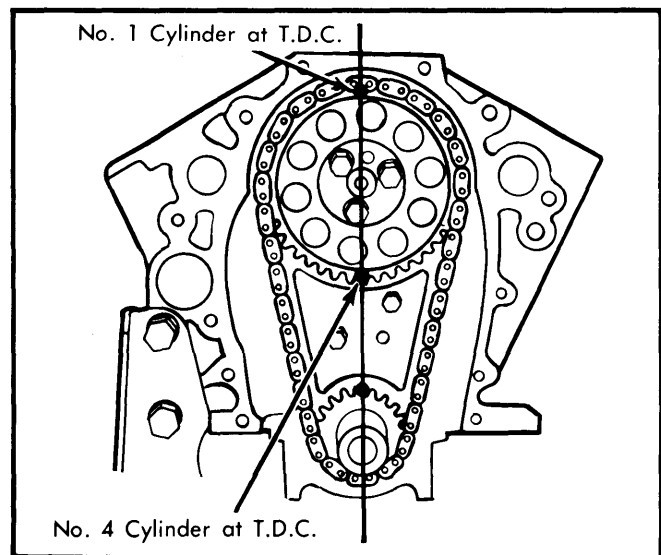

Fig. 12 Camshaft Timing

## CAMSHAFT

**Removal** — With engine removed from vehicle, remove front cover, intake manifold, rocker arm assemblies, Push rods, valve lifters, fuel pump and fuel pump push rod. Remove timing chain and sprocket from end of camshaft. Remove camshaft.

**NOTE** — All camshaft journals are the same diameter. Use care when removing or replacing camshaft to prevent damage to the lobes, journals or bearings. If journals are more than .001" out-of-round, replace camshaft. If replaced, install all new lifters.

## 173" V6 (Cont.)

**Installation** — Lubricate journals with engine oil and apply Molycote or equivalent to camshaft lobes. Carefully install camshaft. Complete installation by reversing removal procedure.

### CAMSHAFT BEARINGS

**Removal** — 1) With crankshaft and camshaft removed, remove cam cover at rear of cylinder block. Use a suitable camshaft bearing removal tool set (J-6098).

2) Remove front intermediate bearing, with tool indexed on front bearing. Remove rear intermediate bearing, with tool indexed on rear bearing. Assemble removal tool on drive handle and remove front and rear bearings by driving them toward the center of the engine.

**Installation** — 1) Install front and rear bearings first. These act as guides for the pilot and center the remaining bearings which are being pulled into place. Install front and rear bearings by driving toward the center of the block.

**NOTE** — Position bearings when installing so that oil holes line up with oil gallery holes in the block.

2) Install each center bearing using same index location used in removal. Pull bearings into bearing saddle from the center. Reverse removal procedure to complete operation.

### ENGINE OILING

**Crankcase Capacity** — 4 quarts with or without filter change.

**Oil Filter** — Full flow type. Change at first oil change and every other one thereafter.

**Normal Oil Pressure** — 30-45 psi at 2000 RPM.

**Pressure Regulator Valve** — Located in oil pump body. Not adjustable.

### ENGINE OILING SYSTEM

Oil is supplied under pressure by a gear type pump, driven by the distributor, which in turn is driven by a helical gear on the camshaft. The main oil gallery (along the left of the camshaft) feeds oil through drilled passages to the camshaft and crankshaft to lubricate the bearings. The valve lifter oil gallery feeds valve lifters, which through hollow push rods feed individually mounted rocker arms. All other components are lubricated by splash or nozzle.

### OIL PUMP

**Disassembly** — Remove pump cover and mark teeth on both gears so they may be reassembled with the same teeth indexing. Remove idler gear, drive gear and shaft from pump body. Remove pressure regulator valve retaining pin, valve and spring. Remove oil pick-up tube from body only if replacing.

**NOTE** — If pump gears or body are damaged or worn, replacement of the entire pump assembly is necessary. Do not disturb pick-up screen on pipe. This is serviced as an assembly only. See Fig. 13.

**Reassembly** — Apply sealer to end of pick-up pipe and tap into place. Install pressure regulator valve and drive gear and shaft into body. Install idler gear and pump cover. Check drive shaft for free operation. Reinstall oil pump to engine. Be sure pick-up screen is parallel with oil pan rails. Install oil pan.

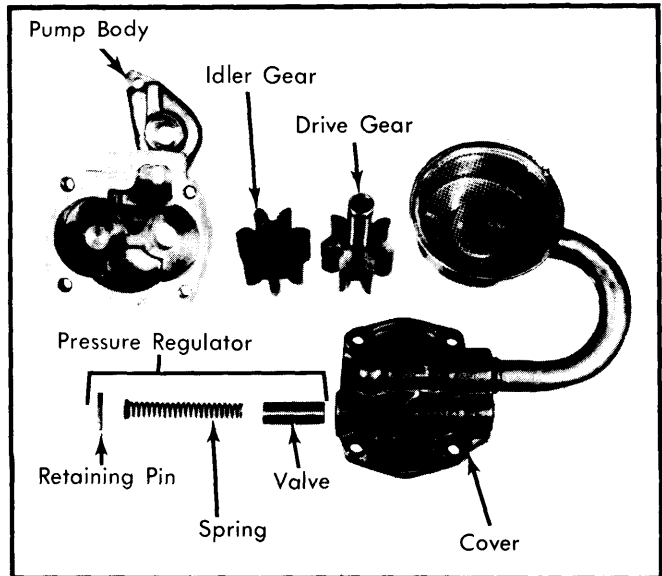

Fig. 13 Oil Pump — Exploded View

### TIGHTENING SPECIFICATIONS

Application	Ft. Lbs. (mkg)
Cylinder Head .....	65-75 (8.99-10.37)
Connecting Rod Cap .....	34-40 (4.70-5.53)
Main Bearing Cap .....	63-74 (8.71-10.23)
Camshaft Cover .....	6-9 (.83-1.24)
Rocker Arm Cover .....	6-9 (.83-1.24)
Oil Pump .....	26-35 (3.60-4.84)
Oil Pump Cover .....	6-9 (.83-1.24)
Oil Pan	
6 mm Bolts .....	6-9 (.83-1.24)
8 Bolts .....	14-22 (1.94-3.04)
Front Cover	
8 mm Bolts .....	13-18 (1.80-2.49)
10 mm Bolts .....	20-30 (2.77-4.15)
Camshaft Sprocket .....	15-20 (.207-2.77)
Torsional Damper .....	66-84 (9.13-11.61)
Flywheel .....	45-55 (6.22-7.60)
Flex Plate to Torque Converter .....	25-35 (3.46-4.84)
Clutch Pressure Plate .....	13-18 (1.80-2.49)
Exhaust Manifold .....	22-28 (3.04-3.87)
Intake Manifold .....	20-25 (2.77-3.46)
Water Outlet .....	20-30 (2.77-4.15)
Water Pump	
6 mm Bolts .....	6-9 (.83-1.24)
8 mm Bolts .....	13-18 (1.80-2.4)
10 mm Bolts .....	20-30 (2.77-4.15)

# General Motors V6 Engines

## 173" V6 (Cont.)

### ENGINE SPECIFICATIONS

GENERAL SPECIFICATIONS										
Year	Displ.		Carburetor	HP at RPM	Torque (Ft. Lbs. at RPM)	Compr. Ratio	Bore		Stroke	
	cu. ins.	cc					in.	mm	in.	mm
1980	173	2800	2-Bbl.	.....	.....	8.6:1	3.50	89	3.0	76

CRANKSHAFT MAIN & CONNECTING ROD BEARINGS							
Engine	MAIN BEARINGS				CONNECTING ROD BEARINGS		
	Journal Diam. In. (mm)	Clearance In. (mm)	Thrust Bearing	Crankshaft End Play In. (mm)	Journal Diam. In. (mm)	Clearance In. (mm)	Side Play In. (mm)
173" 2.8 L	2.4937-2.4947 (63.340-63.364)	.0017-.003 (.044-.076)	No. 3	.002-.008 (.05-.20)	1.9983-1.9993 (50.758-50.784)	.0014-.0035 (.036-.091)	.006-.017 (.16-.44)

VALVES							
Engine & Valve	Head Diam. In. (mm)	Face Angle	Seat Angle	Seat Width In. (mm)	Stem Diameter In. (mm)	Stem Clearance In. (mm)	Valve Lift In. (mm)
173" 2.8 L Int.	.....	45°	46°	.0492-.0590 (1.25-1.50)	.....	.001-.0026 (.026-.068)	.231 (5.87)
Exh.	.....	45°	46°	.0630-.0748 (1.60-1.90)	.....	.001-.0026 (.026-.068)	.262 (6.67)

PISTONS, PINS, RINGS						
Engine	PISTONS	PINS		RINGS		
	Clearance In. (mm)	Piston Fit In. (mm)	Rod Fit In. (mm)	Rings	End Gap In. (mm)	Side Clearance In. (mm)
173" 2.8 L	.0017-.0027 (.043-.069)	.00025-.00035 (.0065-.0091)	.0007-.002① (.0187-.0515)	1	.010-.020 (.25-.50)	.0012-.0027 (.030-.070)
				2	.010-.020 (.25-.50)	.0015-.0037 (.040-.095)
				3	.020-.055 (.51-1.40)	.0078② (.199)

① - Interference fit.

② - Maximum clearance permitted.