

151" 4 CYLINDER

IDENTIFICATION CODING

ENGINE IDENTIFICATION

Engine can be identified by the fifth digit of the Vehicle Identification Number, located on the left front of the instrument panel. Engines are also marked with an engine code stamping, located on pad at left front of cylinder block below cylinder head.

Engine	VIN Code
151" (2.5L)	
Monza, Starfire & Sunbird	V
Citation, Omega, Phoenix & Skylark	5

ENGINE REMOVAL

See Engine Removal at end of ENGINE Section.

CYLINDER HEAD & MANIFOLDS

INTAKE MANIFOLD

Removal – 1) Remove air cleaner and PCV valve. Drain cooling system. Disconnect fuel lines, vacuum lines and electrical connections at carburetor and carburetor spacer.

2) Remove manifold-to-cylinder head bolts and remove intake manifold.

Installation – 1) Install manifold and gasket on cylinder head. Start all bolts and finger tighten only.

2) Torque manifold-to-cylinder head bolts using torque sequence shown in Fig. 1. Reverse removal procedure to complete installation

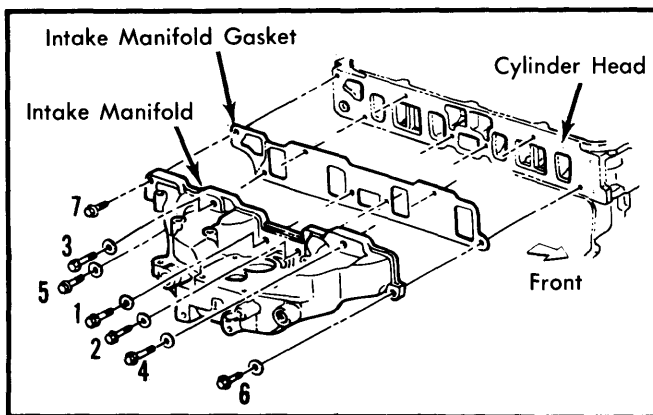

Fig. 1 Intake Manifold Bolt Torque Sequence

EXHAUST MANIFOLD

Removal – 1) Remove air cleaner and carburetor preheat tube. Remove torque strut bolts at radiator support panel and at cylinder head.

2) Disconnect exhaust pipe from manifold, remove oil dip stick attaching bolt.

3) Remove exhaust manifold bolts and remove manifold.

Installation – 1) Install manifold and gasket on cylinder head. Start all bolts and finger tighten only.

2) Torque manifold-to-cylinder head bolts using torque sequence shown in Fig. 2. Reverse removal procedure to complete installation.

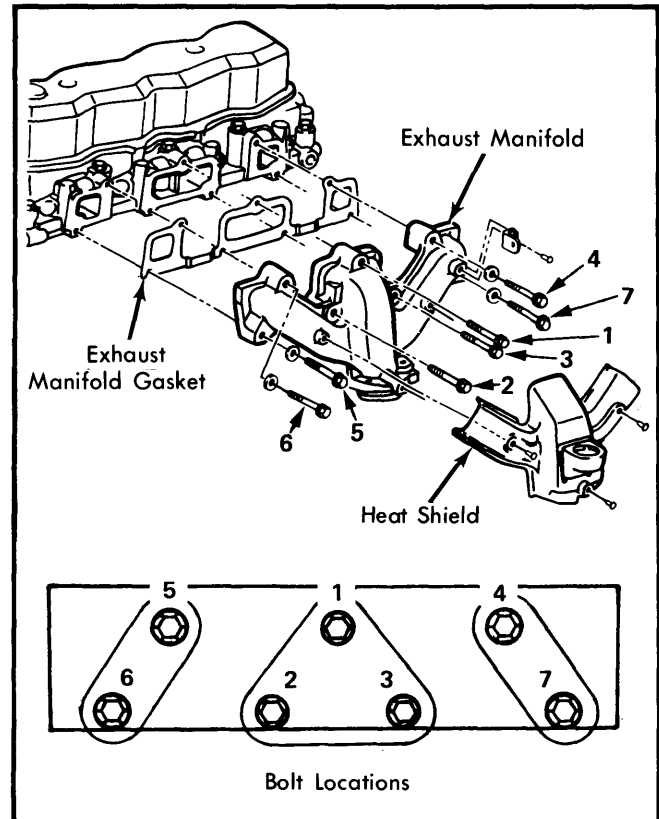

Fig. 2 Exhaust Manifold Bolt Torque Sequence

CYLINDER HEAD

Removal – 1) Drain cooling system and remove air cleaner. Remove intake and exhaust manifolds as previously described.

2) Remove alternator, A/C and power steering units. Disconnect all hoses and electrical connections at cylinder head and identify for reinstallation.

3) Disconnect spark plug wires and remove spark plugs. Remove rocker arm cover and back off rocker arm nuts, then pivot rocker arms to clear push rods and remove push rods.

4) Remove cylinder head bolts and remove cylinder head; place on two blocks of wood to prevent damage.

Installation – 1) Make sure gasket surfaces are clean of foreign matter and free of nicks. Install a new gasket in position over dowel pins on cylinder block. Carefully install cylinder head over dowel pins and gasket.

NOTE – Make sure all cylinder head bolt threads are clean and oiled. (If the threads are dirty correct torque cannot be achieved).

151" 4 CYLINDER (Cont.)

2) Coat heads and threads of cylinder head bolts with sealing compound. Install all cylinder head bolts and finger tighten only. Gradually tighten bolts following the sequence in Fig. 3. Reverse removal procedure to complete installation.

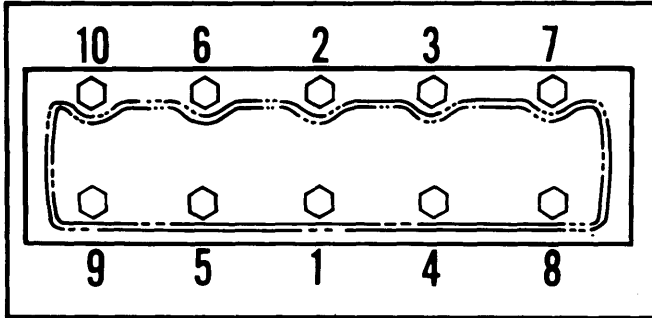

Fig. 3 Cylinder Head Tightening Sequence

VALVES

VALVE ARRANGEMENT

I-E-I-E-I-E-I

VALVE GUIDE SERVICING

Valve guides are an integral part of the cylinder head. If valve guide-to-stem clearance is excessive (see engine specifications) guides should be reamed and new oversize valves should be installed.

VALVE STEM OIL SEALS

Oil seals are used on all valve stems and should be replaced whenever valve spring is removed or valve service is performed.

VALVE SPRINGS

Removal - 1) Remove rocker arm cover. Remove rocker arms on cylinder to be serviced, also remove spark plugs. Install air hose adapter to spark plug hole and apply air pressure.

2) With rocker arms removed, install rocker arm nut loosely on stud. Using spring compressor (J-5892-1 or equivalent), compress valve spring and remove valve locks. Remove tool, retainer, cup shield, spring and valve stem oil seal.

Installation - Reverse removal procedure to complete installation.

NOTE - Valve spring installation height is 1.69". Test valve spring tension with tester while removed. Springs should be compressed to 1.66" without internal dampner. Proper tension is 78-86 lbs. at this height.

HYDRAULIC VALVE LIFTERS

Valve lifters are serviced as complete units. Parts are not interchangeable between lifters. If lifter shows signs of wear or is noisy, it should be replaced.

Check cam mating surface for wear and if present, inspect camshaft. Replace parts as necessary. See Fig. 4.

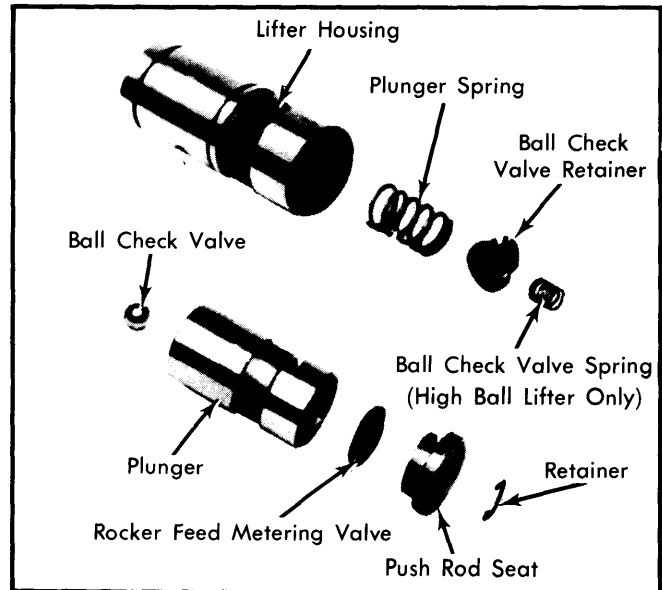

Fig. 4 Hydraulic Valve Lifter Assembly.

PISTONS, PINS & RINGS

OIL PAN

See Oil Pan Removal at end of ENGINE Section.

PISTON & ROD ASSEMBLY

NOTE - New pistons must be installed in same cylinders for which they were fitted. Install used pistons in same cylinders from which they were removed.

NOTE - Piston should be at bottom of stroke and covered with a cloth to collect cuttings.

Removal - 1) With cylinder head and oil pan removed, use a ridge reamer to remove any ridge or deposits from upper end of cylinder bore.

2) Check connecting rod and piston for proper identification and mark if necessary. Remove bearing cap. Remove piston and rod assembly through top of cylinder block, taking care not to damage cylinder wall or crankshaft journal.

Installation - 1) Lightly coat cylinder bores and pistons with oil. Insure ring gaps are evenly spaced and marked side of compression ring is facing upward.

2) Install ring compressor on piston, insuring ring gap spacing does not change. Using suitable tool, gently tap piston assembly into correct cylinder bore, taking care not to damage cylinder bore.

NOTE - Notch in top of piston faces front of engine, raised notch on side of rod at bearing end should be opposite notch in piston when installed. See Fig. 5.

3) Install bearing caps and tighten nuts. Reverse removal procedure to complete installation.

151" 4 CYLINDER (Cont.)

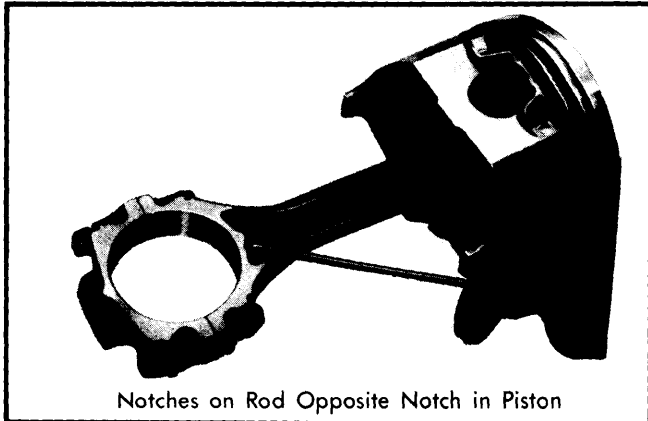

Notches on Rod Opposite Notch in Piston

Fig. 5 Making Sure Connecting Rod and Piston Assembly are Properly Indexed

FITTING PISTONS

Pistons are available in standard, .010", .020", and .030" oversize. Selective fitting of each piston is required. Once proper piston has been selected, mark the piston with the cylinder number it was fitted for.

NOTE — Measure cylinder bore and pistons at room temperature, otherwise improper fit will result.

PISTON PINS

Pins are press fit in piston. Oversize pins are available, piston and rod must be reamed for correct fit. Remove and install piston pins using arbor press and suitable adapters.

CRANKSHAFT & ROD BEARINGS**MAIN & CONNECTING ROD BEARINGS**

Connecting Rod Bearings — 1) Remove oil pan. Turn crankshaft and rod to be serviced to bottom of stroke. Remove bearing cap and lower shell.

2) Check clearances using Plastigage method and replace bearings as necessary. On VIN 5 engines, bearings are available in standard, .001", .002" and .010" undersize. On VIN V engines bearings are available in standard, .001" and .002" undersize.

3) Push piston and rod assembly up far enough to remove upper bearing shell.

4) Rotate crankshaft after installation of new bearing to insure crankshaft is not binding. Reverse removal steps to complete assembly.

Main Bearings — 1) Replace main bearings in pairs. Do not shim or mix bearing size and do not use a new bearing with an old bearing.

2) Remove oil pan and remove bearing cap and bearing to be serviced. Using suitable tool, rotate upper bearing shell out by turning crankshaft in direction of locating notch in bearing saddle.

3) Check clearances using Plastigage method and replace bearings as necessary. On VIN 5 engines, bearings are available in standard, .001", .002" and .010" undersize. On VIN V engines bearings are available in standard, .001" and .002" undersize.

4) With new bearings lightly oiled and installed, rotate crankshaft to check for excessive drag.

THRUST BEARING ALIGNMENT

Measure crankshaft end play (see specifications) by forcing the crankshaft to the extreme front position. Measure at front end of thrust bearing with a feeler gauge, if not within specifications thrust bearing must be replaced.

REAR MAIN BEARING OIL SEAL

Removal — 1) Remove transmission, clutch housing and flywheel.

2) Remove rear main bearing oil seal by prying it out with a screwdriver taking care not to scratch crankshaft.

Installation — 1) Coat new seal with engine oil and install with lip toward engine. Ensure that seal is firmly in place.

2) Install flywheel, clutch housing and transmission.

CAMSHAFT**ENGINE FRONT COVER**

Removal — 1) Remove engine drive belts. Remove center hub and slide hub and pulleys from crankshaft.

2) On VIN 5 engines, remove lower alternator bracket. Remove front engine mount-to-cradle nuts and use suitable engine support equipment to raise engine. Remove engine-to-mount bolts and remove support bracket and mount as an assembly.

3) On all engines, remove 2 oil pan-to-cover screws and front cover-to-block screws. Then, pull cover slightly forward to allow cutting of oil pan front seal. Using a sharp knife or some other suitable tool, cut pan seal flush with engine block on both sides. Remove front cover and attached portion of oil seal.

Installation — 1) Clean mating surfaces of engine block and front cover. Cut tabs off new oil pan front seal. (See Fig. 6) and install seal on front cover, pressing tips into holes provided in cover. Apply silicone rubber sealer or equivalent to joint at oil pan and cylinder block.

2) Install centering tool (J-23042 or equivalent) in front cover seal. Install front cover to block, install and partially tighten 2 oil pan-to-front cover screws.

3) Install cover-to-block screws, tighten all screws. Remove centering tool. Reverse removal procedure to complete installation

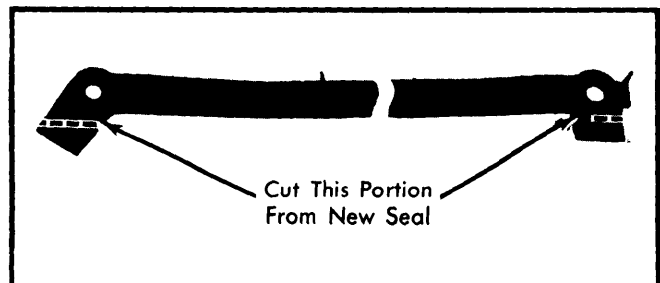

Fig. 6 Oil Pan Front Seal Modification

151" 4 CYLINDER (Cont.)

FRONT COVER OIL SEAL

Removal & Installation – 1) Remove oil seal from front cover using care not to damage front cover.

2) Position new seal with lip toward rear of engine. Drive into cover using installer (J-23042 or equivalent).

3) Lightly coat oil seal contact area of balancer with engine oil. Position balancer on crankshaft and push it onto the crankshaft until it bottoms, install center bolt and torque. Reverse removal procedure to complete installation.

CAMSHAFT & TIMING GEAR

NOTE – On VIN 5 engines, remove engine and install on engine stand. On VIN V engines, remove radiator, grille, fan and water pump pulley.

Removal – 1) Remove rocker arm cover, loosen rocker arms and pivot to one side, remove push rods. Remove push rod cover and remove valve lifters.

2) Remove distributor, fuel pump, and oil pump drive shaft. See Fig. 7. Remove front pulley and timing gear cover.

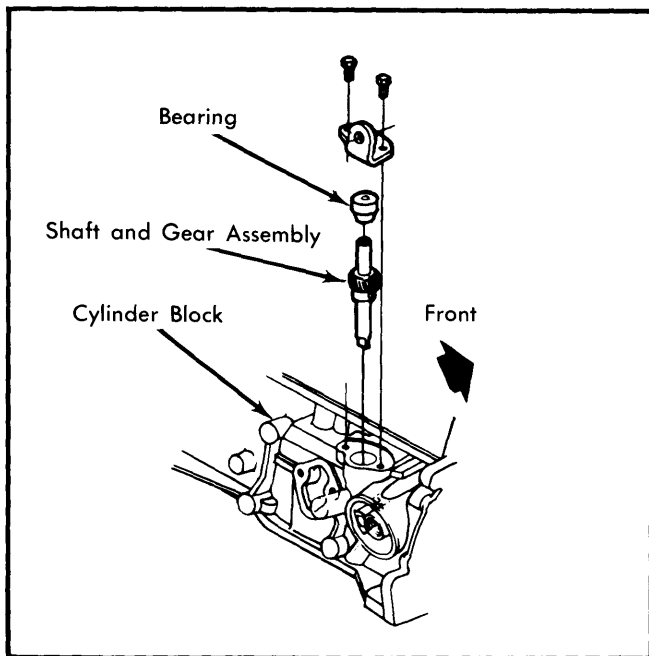

Fig. 7 Removing Oil Pump Drive Shaft

3) Remove the camshaft thrust plate retaining screws by working through holes in camshaft gear. See Fig. 8. Remove camshaft and gear assembly by pulling it through front of block. Use care not to damage camshaft bearings.

NOTE – Camshaft timing gear is pressed onto camshaft. When removing, ensure that Woodruff key does not damage camshaft.

Installation – 1) Install gear spacer ring and thrust plate over end of camshaft, and install Woodruff key in shaft keyway.

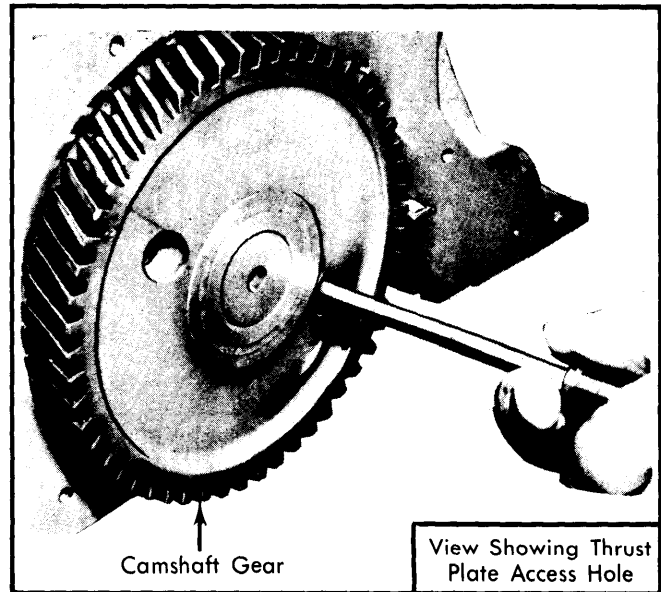

Fig. 8 Removing Thrust Plate Screw with Screwdriver Inserted Through Timing Gear

2) Install camshaft gear and press it onto camshaft until it bottoms against gear ring spacer ring. Measure the end clearance of thrust plate, it should be .0015-.0050". If less than .0015", spacer ring should be replaced. If more than .0050", thrust plate should be replaced.

3) Coat camshaft journals with engine oil and install camshaft in engine block being careful not to damage camshaft bearings. Align timing marks by rotating camshaft and crankshaft until valve timing marks on gear teeth will line up. Engine is now timed in the number 4 cylinder firing position.

4) Install 2 camshaft thrust screws and torque to specifications. Reverse removal procedure to complete installation.

CAMSHAFT BEARINGS

Removal – 1) Remove engine and install on engine stand. Remove camshaft and flywheel, drive out expansion plug from rear camshaft bearing by driving from inside.

2) Using bearing remover J-21473-1, drive out front bearing toward rear and rear bearing toward front. Install extension J-21054-1 and drive center bearing out toward rear.

Installation – 1) Install bearings using reverse procedure, ensuring that oil holes line up in camshaft and engine block.

2) Install front camshaft bearing so that bearing is recessed about $\frac{1}{8}$ " into engine block. This will allow for lubrication of timing gears. Reverse removal procedure to complete installation.

General Motors 4 Engines

151" 4 CYLINDER (Cont.)

ENGINE OILING

ENGINE OILING

Crankcase Capacity – 3 quarts without oil filter.

Oil Filter – Full flow type. Change oil filter at every oil change.

Normal Oil Pressure – 36-41 psi. @2000 RPM.

Pressure Regulator Valve – Located in oil pump body. Not adjustable.

ENGINE OILING SYSTEM

Engine lubrication is accomplished through a gear type pump which picks up oil from the oil pan sump, pumps it through the full flow oil filter and into oil passage which runs along the right side of the block and intersects the lifter bosses. Oil is then routed to the camshaft and crankshaft bearings through smaller drilled passages. Oil is supplied to the rocker arms through the hydraulic lifters which feed oil up the push rod tubes to the rocker arms. Bypass valves are located in the pickup screen, oil filter mounting and oil pump to allow for any clogged or restricted conditions. Many internal engine parts have no direct oil feed and rely on gravity or splash oil from other direct feed components. Oil returns to the oil sump through oil return holes in cylinder head and block. See Fig. 9.

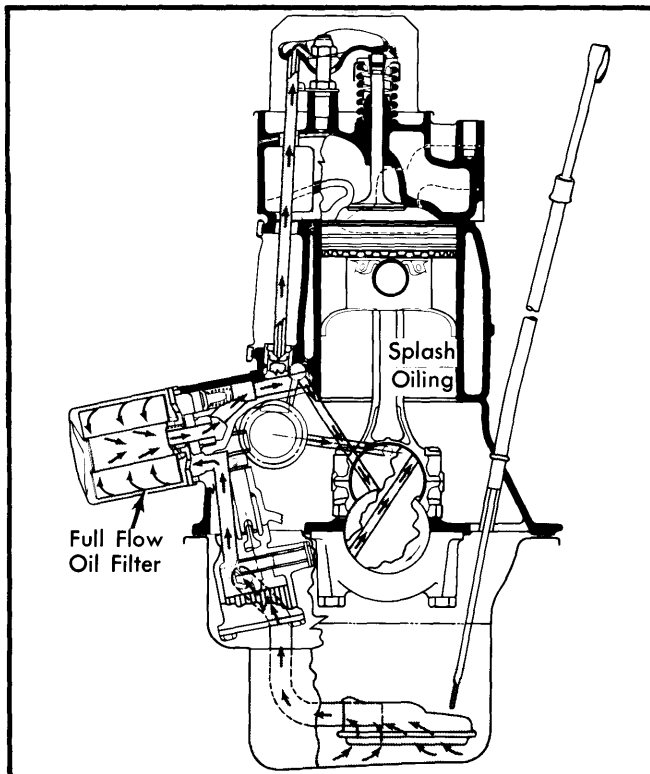

Fig. 9 Engine Oiling System

OIL PUMP

Oil pump is located in oil sump, oil pan must be removed for access, See *Oil Pan Removal* at end of *ENGINE* Section. Remove 2 flange bolts and nut from main bearing cap bolt

and remove pump and screen as an assembly. Do not disturb oil pickup pipe on screen or body. Disassemble pump and inspect for excessive wear or cracks. Replace pump as a unit if parts are defective. See Fig. 10.

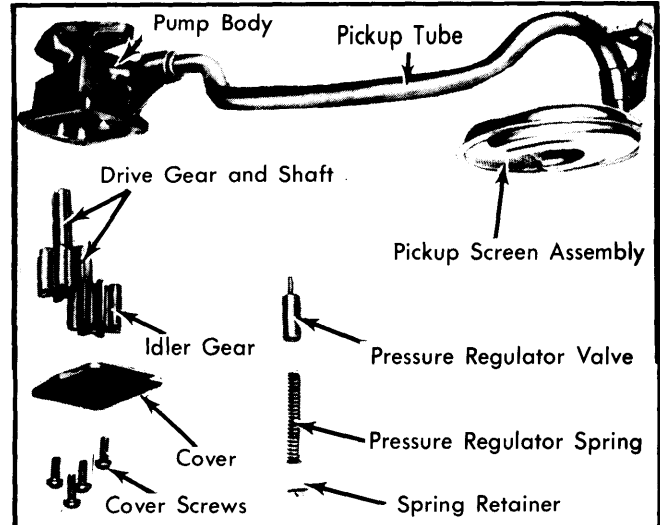

Fig. 10 Exploded View of Engine Oil Pump Assembly

TIGHTENING SPECIFICATIONS

Application	Ft. Lbs.
Cylinder Head	
VIN 5	Ⓢ75
VIN V	Ⓢ95
Flywheel-to-Crankshaft	
VIN 5	44
VIN V	55
Connecting Rod	
VIN 5	32
VIN V	30
Harmonic Balancer	
VIN 5	200
VIN V	160
Engine Front Cover	6
Intake Manifold-to-Cyl. Head	29
Exhaust Manifold-to-Cyl. Head	
VIN 5	44
VIN V	35
Main Bearing Cap	
VIN 5	70
VIN V	65
Oil Pan	6
Oil Pump-to-Block	
VIN 5	22
VIN V	20
Water Pump	
VIN 5	25
VIN V	18
Thermostat Housing	
VIN 5	25
VIN V	20
Carburetor-to-Manifold	
VIN 5	15
VIN V	12
Rocker Arm-to-Stud	20

Ⓢ – Requires Thread Sealer.

General Motors 4 Engines

6-73

151" 4 CYLINDER (Cont.)

ENGINE SPECIFICATIONS

GENERAL SPECIFICATIONS						
Engine	Net HP At RPM	Torque (Ft. Lbs. at RPM)	Compr. Ratio	Bore	Stroke	Displ. Cu. Ins.
151"	86@4000	128@2800	8.3:1	4.00"	3.00"	151"

VALVES							
Engine & Valve	Head Diam.	Face Angle	Seat Angle	Seat Width	Stem Diameter	Stem Clearance	Valve Lift
151"							
Int.	1.72"	45°	46°	.353-.0747"	.3418-.3425"	.0010-.0027"	.406"
Exh.	1.50"	45°	46°	.580-.0971"	.3418-.3425"	.0010-.0027" ①	.406"

① — Measured at top of guide. Bottom is .0020-.0037"

PISTONS, PINS, RINGS						
Engine	PISTONS Clearance	PINS		RINGS		
		Piston Fit	Rod Fit	Rings	End Gap	Side Clearance
151"	①.0025-.0033"	.0002-.0004"	Press Fit	1	.015-.025"	.003"
				2	.009-.019"	.003"
				3	.015-.055"	.003"

① — Top clearance — Bottom clearance is .0017-.0041"

CRANKSHAFT MAIN & CONNECTING ROD BEARINGS							
Engine	MAIN BEARINGS				CONNECTING ROD BEARINGS		
	Journal Diam.	Clearance	Thrust Bearing	Crankshaft End Play	Journal Diam.	Clearance	Side Play
151"	2.300"	.0005-.0022"	No. 5	.0035-.0085"	2.000"	.0005 -.0026"	.006-.022"

VALVE TIMING				
Engine	INTAKE		EXHAUST	
	Open (BTDC)	Close (ALDC)	Open (BLDC)	Close (ATDC)
151"	33°	79°	74°	38°

CAMSHAFT			
Engine	Journal Diam.	Clearance	Lobe Lift
151"	1.869"	.0007-.0027"	.230"