

255", 302" & 351" V8

IDENTIFICATION CODING

ENGINE IDENTIFICATION

Engine code is fifth digit of Vehicle Identification Number, located on upper left of instrument panel.

Application	VIN Code
255" (4.2L) 2-Bbl.	D
302" (5.0L) 2-Bbl.	F
351"W (5.8L) 2-Bbl.	G

ENGINE REMOVAL

See Engine Removal at end of ENGINE Section.

CYLINDER HEAD & MANIFOLDS

INTAKE MANIFOLD

Removal - 1) Drain cooling system. Remove air cleaner and intake duct assembly. Remove automatic choke heat tube, upper radiator hose at engine, heater hoses at intake manifold and water pump.

2) Disconnect all vacuum lines and electrical wires (remove distributor cap and wires as an assembly), then remove distributor. Disconnect and remove coil, fuel line, accelerator linkage, and Thermoactor by-pass valve and hose.

3) If vehicle is equipped with air conditioning, remove compressor to intake manifold brackets. Remove intake manifold and carburetor as an assembly.

Installation - 1) Apply suitable oil resistant sealer at four junction points of seals and gaskets. Position front and rear seals on cylinder block and new gaskets on heads. Make sure that holes in gaskets are aligned with holes in cylinder head.

2) Position gaskets so they are interlocked with seal tabs. Using guide pins, lower manifold onto engine and check for correct positioning of gaskets and seals before installing bolts. Remove guide pins, install bolts and tighten to specification, following the sequence shown in Fig. 1.

3) Operate the engine until it reaches normal operating temperature, then, retorque manifold bolts.

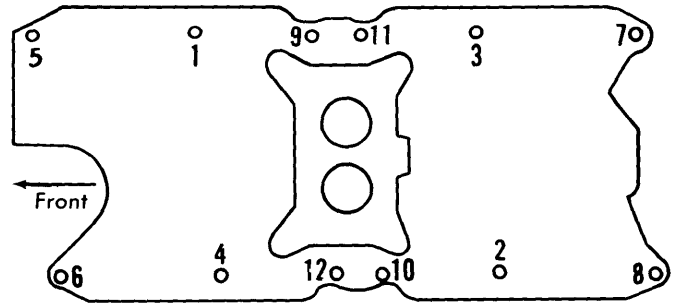

Fig. 1 Intake Manifold Tightening Sequence

CYLINDER HEAD

Removal - 1) Remove intake manifold and carburetors as an assembly. Remove rocker arm covers.

2) Disconnect A/C compressor and position to one side. Do not disconnect refrigerant lines. Disconnect power steering pump and bracket, remove drive belt from pump pulley and position to one side. Remove alternator mounting bracket bolt, air cleaner inlet duct and ignition coil.

3) Disconnect exhaust pipe at manifold. On some engines it may be necessary to remove exhaust manifold to gain access to lower cylinder head bolts. Remove push rods, then remove cylinder head.

Installation - Clean old gasket material from cylinder head and block. Position head gasket over dowels and onto block. Install cylinder head. Install bolts and tighten in 3 steps to specifications, following sequence in Fig. 2.

Cylinder Head Tightening Specifications (Ft. Lbs.)

Step No.	255" & 302"	351"
Step 1	55-65	85
Step 2	65-72	95
Step 3		105-112

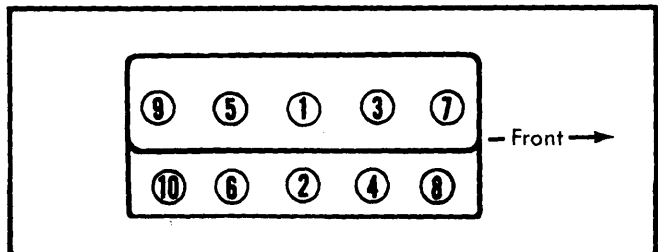

Fig. 2 Cylinder Head Tightening Sequence (All V8 Engines)

VALVES

VALVE ARRANGEMENT

All Engines - E-I-E-I-E-I-E-I (Left bank, front to rear).
I-E-I-E-I-E-I-E (Right bank, front to rear).

255", 302" & 351" V8 (Cont.)

VALVE GUIDE SERVICING

To ream guides for installation of valves with oversize stems, always use reamers in sequence and reface valve seat after valve guide is reamed. Reamers are furnished .003" oversize with standard diameter pilot; .015" oversize reamer with .003" oversize pilot; and .030" oversize reamer with .015" oversize pilot.

VALVE STEM OIL SEALS

Cup or umbrella type seals are used on all valves. Install seals with cup side down over valve guide, using a $\frac{5}{8}$ " deep socket and plastic tipped hammer to properly seat seal.

VALVE SPRINGS

Removal — 1) Remove rocker arm cover and spark plug on cylinder to be serviced. Be sure piston is at top of stroke with both valves closed. Install air line with adapter in spark plug hole.

NOTE — If air pressure fails to hold valve closed, remove cylinder head for inspection of valve seat.

2) Remove required rocker arms and push rods. Use suitable spring compression tool (T62F-6565-A or 6513-HH) to compress valve and remove retainer locks, sleeve, spring retainer and valve spring. Remove and discard valve stem seal. Do not remove air pressure as this will allow valve to fall into cylinder if piston has been forced to bottom of cylinder.

Installation — 1) Lubricate valve stem with engine oil and install new valve stem seal. Place spring in position over valve and install spring retainer and sleeve. Compress valve spring and install locks. Remove air pressure and adapter and install spark plugs.

2) Apply Lubriplate or equivalent to ends of push rods and tip of valve stems. Install rocker arms and tighten to specifications.

VALVE SPRING INSTALLED HEIGHT

Spring ends must be square within $\frac{3}{64}$ ". Installed height of valve spring must not exceed specifications. Measure height from surface of cylinder head pad to underside of spring retainer. See Fig. 3. If height is greater than specified, install .030" spacer on head under spring to bring height within limits.

CAUTION — Install spacers only if necessary. Do not use more than 2 spacers, as this will overstress springs and overload camshaft lobes.

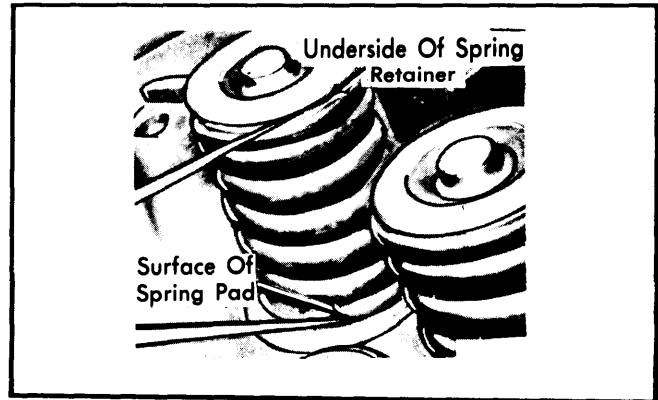

Fig. 3 Measuring Valve Spring Installed Height

Engine	Installed Height
255" & 302"	
Int.	1 $\frac{43}{64}$ "-1 $\frac{45}{64}$ "
Exh.	1 $\frac{37}{64}$ "-1 $\frac{39}{64}$ "
351"	
Int.	1 $\frac{49}{64}$ "-1 $\frac{51}{64}$ "
Exh.	1 $\frac{37}{64}$ "-1 $\frac{39}{64}$ "

HYDRAULIC VALVE LIFTER ASSEMBLY

Lifters are serviced as assemblies only and parts are not interchangeable. See Fig. 4. Always check rocker arm-to-valve stem clearance before concluding a noisy lifter is defective. After cleaning and reassembling lifters, they should be tested for leakdown rate. Use lifter tester according to directions of manufacturer. Leakdown rate is 10-50 seconds measured at $\frac{1}{16}$ " plunger travel under a 50 pound load.

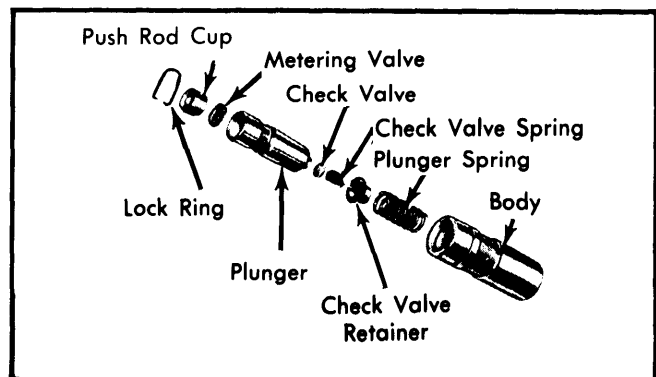

Fig. 4 Exploded View of Valve Lifter Assembly

HYDRAULIC VALVE LIFTER ADJUSTMENT

Repeated valve (seat and face) reconditioning operations will decrease valve stem to rocker arm clearance to point that if compensation is not made, valve lifters will cease to function. To compensate for any dimensional changes in valve mechanism, a .060" shorter or a .060" longer replacement

255", 302" & 351" V8 (Cont.)

push rod is available. To determine whether or not a longer or shorter push rod is necessary, clearance between rocker arm and valve stem must be checked. Use suitable tool and slowly collapse valve lifter until plunger is bottomed. Hold lifter down while checking clearance. Procedure for checking valve clearance is as follows:

NOTE — Valve lifter must be completely collapsed when checking valve clearance.

1) Rotate crankshaft until No. 1 piston is at TDC (point "A" in Fig. 5) after compression stroke as indicated by timing mark on crankshaft damper and pointer. Make a chalk mark on damper 180° (point "B") from TDC mark. Make a chalk mark on damper 90° (point "C") clockwise from TDC mark.

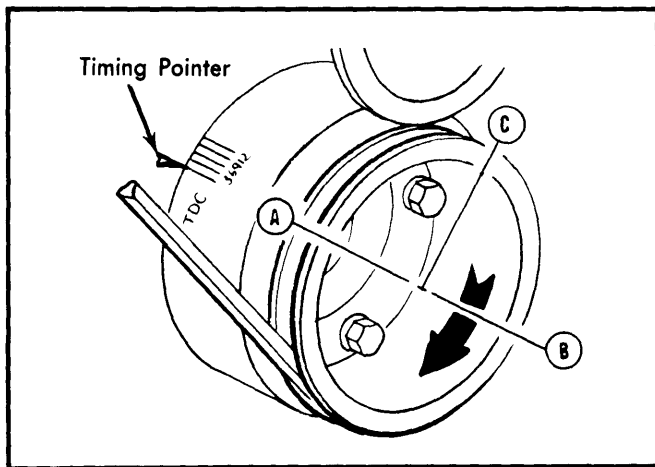

Fig. 5 Different Positions to Place Crankshaft Damper When Making Hydraulic Valve Lifter Adjustment

2) With damper at point "A", check following valve clearances with specifications:

255" & 302" — Intake No. 1,7,8. Exhaust No. 1,5,4.
351" — Intake No. 1,4,8. Exhaust No. 1,3,7.

3) Rotate crankshaft 180° clockwise from point "A" so that point "B" is opposite pointer. Check following valve clearances:

255" & 302" — Intake No. 4,5. Exhaust No. 2,6.
351" — Intake No. 3,7. Exhaust No. 2,6.

4) Rotate crankshaft 270° clockwise from point "B" so point "C" is opposite pointer. Check following valve clearances:

255" & 302" — Intake No. 2,3,6. Exhaust No. 3,7,8.
351" — Intake No. 2,5,6. Exhaust No. 4,5,8.

Valve Clearances

Application	Desired	Allowable
255"	.123-.173"	.098-.198"
302" & 351"	.096-.163"	.071-.193"

5) If clearance is less than specified, install shorter push rods; if greater than specified, install longer push rods.

PISTONS, PINS & RINGS

OIL PAN

See Oil Pan Removal at end of ENGINE Section.

PISTON & ROD ASSEMBLY

NOTE — New pistons must be installed in same cylinders for which they were fitted and used pistons in same cylinder from which they were removed.

Removal — 1) With cylinder head and oil pan removed, use a suitable ridge cutter to remove any ridge or deposits on upper end of cylinder bore.

NOTE — Piston must be at bottom of stroke and covered with a cloth to collect cuttings.

2) Inspect connecting rods and caps for cylinder identification and mark as necessary. Remove rod cap and push piston and rod assembly out top of cylinder block, taking care not to nick crankshaft journal or cylinder wall. Remove bearing inserts and install cap to its respective rod.

Installation — 1) Lightly coat cylinder bores, pistons, and rings with engine oil. Ensure that ring gaps are properly spaced and install ring compressor on piston. See Fig. 6.

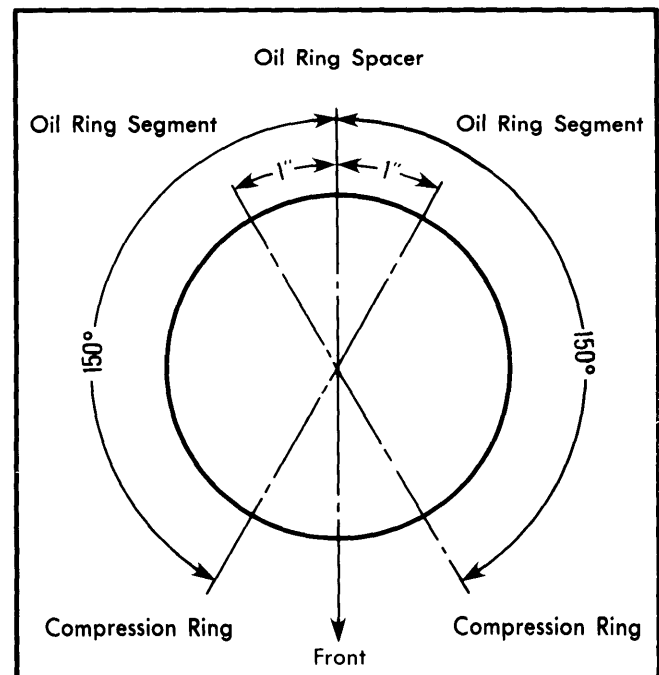

Fig. 6 Piston Ring Gap Spacing

2) Install each piston and rod assembly (with notch on piston head facing front of engine) in its respective bore. See Fig. 7. Guide connecting rod onto crankshaft journal while tapping piston head with wooden hammer handle to seat connecting rod against crankshaft. Install rod caps and tighten. Check bearing clearance and connecting rod side clearance.

255", 302" & 351" V8 (Cont.)

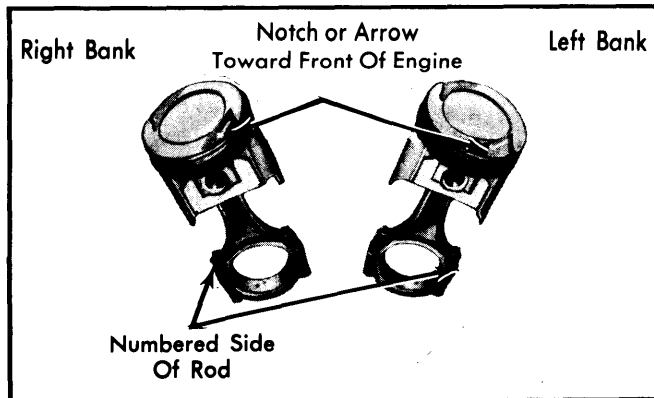

Fig. 7 Piston and Connecting Rod Index Mark Locations

FITTING PISTONS

Measure piston at centerline of piston pin bore 90° to pin bore axis. Measure cylinder bore at right angles to centerline of crankshaft, below ring travel. Piston clearance should be within specifications.

PISTON PINS

Piston pins are replaced using arbor press and suitable pilots and drivers. See Fig. 8. Pins are a press fit in bore.

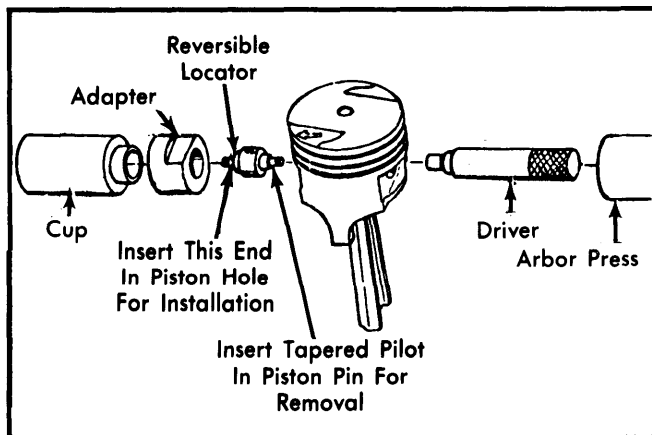

Fig. 8 Tool Layout for Removing and Installing Piston Pin

CRANKSHAFT & ROD BEARINGS

MAIN & CONNECTING ROD BEARINGS

NOTE — Following procedures are with oil pan removed.

Removal — Remove connecting rod cap after ensuring caps are marked for identification to rod assembly. Use suitable tool (6331) in oil hole of crankshaft to remove upper half of main bearing by rotating crankshaft in direction of engine rotation. Replace main bearings one at a time.

Installation — 1) Determine crankshaft journal clearance in bearing using Plastigage method. Place a jack under

counterweight adjoining bearing being checked so weight of crankshaft will not compress Plastigage and provide an erroneous reading. See Fig. 9.

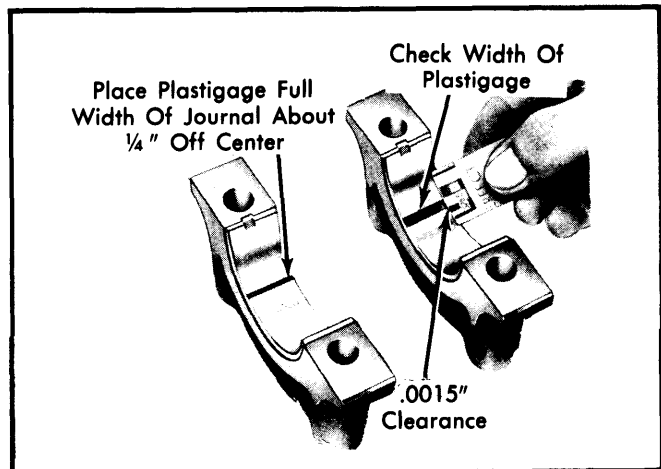

Fig. 9 Using Plastigage to Check Bearing Clearance

2) If bearing clearance is excessive, a .001" or .002" undersize bearing may be used in combination with a standard size bearing. If .002" undersize bearings are used on more than one journal, they may be positioned in cylinder block rather than bearing cap.

3) If standard and .002" undersize combination do not bring bearing clearance within specified limits, crankshaft will have to be refinished and undersized bearings installed.

4) Fit and install bearing inserts in connecting rods and caps so tangs fit into slots provided.

THRUST BEARING ALIGNMENT

Install all main bearing caps except thrust bearing cap and tighten. Install thrust bearing cap with bolts, but only finger tight. Pry crankshaft to front of engine. Then pry thrust bearing cap to rear of engine. While holding crankshaft forward, tighten main bearing cap bolts. Check crankshaft end play.

REAR MAIN BEARING OIL SEAL

Split-type crankshaft rear oil seals may be replaced without removing crankshaft, using the following procedure:

1) Loosen all main bearing bolts, lowering crankshaft not to exceed $\frac{1}{32}$ ". Remove rear main bearing cap, remove seal half from cap. Remove upper seal half with suitable tool, being careful not to scratch or damage crankshaft journal or seal surfaces.

2) Remove oil seal retaining pin from bearing cap (if equipped). Discard pin. Dip seal halves in engine oil. Install upper seal in groove with undercut side of seal toward front of engine by rotating it on seal journal until $\frac{3}{8}$ " protrudes below parting surface. See Fig. 10. Tighten main bearing cap bolts.

255", 302" & 351" V8 (Cont.)

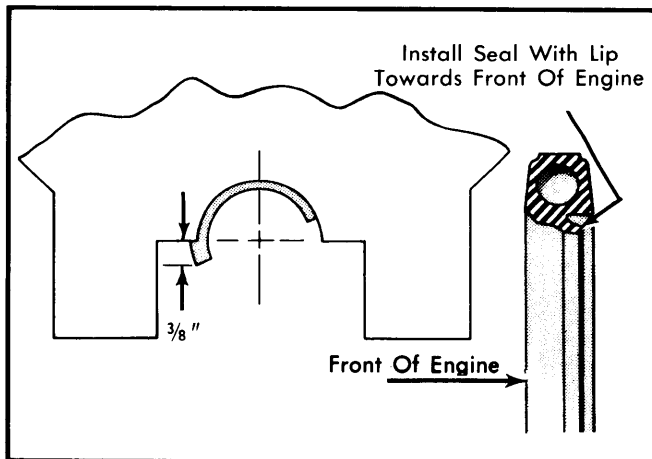

Fig. 10 Split Lip Type Rear Main Bearing Oil Seal

3) Install lower seal in rear bearing cap with undercut side towards front of engine, allowing seal to protrude $\frac{3}{8}$ " above parting surface.

4) Apply thin coating of oil resistant sealer to cap at rear of top mating surface. Install main bearing cap and tighten bolts.

NOTE — Do not apply sealer to area forward of side seal groove.

CAMSHAFT

ENGINE FRONT COVER

Removal — 1) Drain cooling system and crankcase. Remove fan, spacer and all hoses or brackets attached to water pump. Remove crankshaft pulley, and use suitable puller to remove vibration damper. On 255" and 302" engines in Granada and Monarch models, remove oil dipstick.

2) Disconnect fuel pump outlet line from fuel pump, remove fuel pump bolts and lay pump to one side. Remove front cover bolts and cut oil pan gasket flush with cylinder block. Remove front cover and water pump as an assembly.

Installation — Clean all gasket surfaces. Use suitable sealer and install gaskets and seals. Install new front cover seal. Use suitable pilot tool (T61P-6019-B or 6059-F) to center front cover on crankshaft. Install bolts and tighten.

FRONT COVER OIL SEAL

Removal — Remove front cover. Using suitable pin punch, drive out oil seal.

Installation — Coat seal with grease and drive into cover using suitable tools (T53L-200-A and T58P-6700-B). Check seal to make sure that it is fully seated and the spring is positioned properly. Install front cover.

TIMING CHAIN

Inspection — Remove front cover. Rotate crankshaft in counterclockwise direction to take up slack on left side of chain. Establish reference point on block (left side of chain) and measure distance to chain. Rotate crankshaft clockwise to take up slack on right side of chain. Force left side of chain out with fingers and measure distance between reference point and chain. Deflection is difference between two measurements. If deflection exceeds .500", replace timing chain and sprockets.

Removal & Installation — 1) Crank engine until timing marks are positioned properly. See Fig. 11. Remove camshaft sprocket cap screw, washers and fuel pump eccentric. Slide both sprockets and timing chain forward and remove them as an assembly.

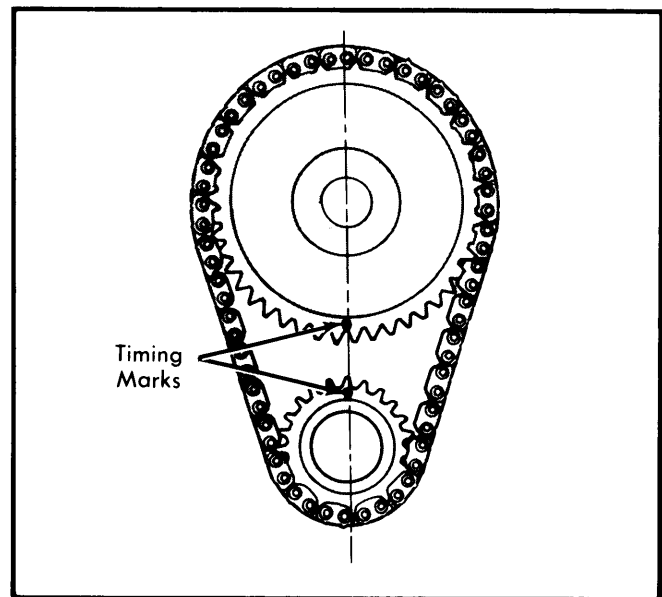

Fig. 11 Timing Chain Sprocket Alignment

2) To install, position timing chain on sprockets with timing marks aligned. See Fig. 11. Slide sprockets and timing chain onto engine as an assembly. Install fuel pump eccentric, washers and sprocket cap screw. Tighten bolt and oil timing chain.

CAMSHAFT

Removal — 1) Drain cooling system and remove radiator, A/C condenser and grille components, as necessary. Remove engine front cover, fuel pump, and sprockets and timing chain as an assembly.

255", 302" & 351" V8 (Cont.)

2) Remove intake manifold and related parts. Remove rocker arm covers, loosen rocker arms and remove push rods. Remove valve lifters.

3) Remove thrust plate and carefully pull camshaft toward front of engine and remove.

Installation — Oil camshaft journals with engine oil and apply Lubriplate or equivalent to camshaft lobes. Carefully slide camshaft through bearings and install camshaft thrust plate with groove toward cylinder block. Install other components previously removed.

CAMSHAFT BEARINGS

Removal & Installation — With camshaft, flywheel and crankshaft removed from engine, push pistons to top of cylinders. Remove camshaft rear bearing bore plug. Using suitable driver-puller tool, remove bearings. When installing new bearings, oil holes must be aligned. Front bearing must be installed specified distance below front face of cylinder block. Bearings are also available .015" undersize.

Front Bearing Installation

Application	Installation Distance
255", 302" & 351"005-.020"

CAMSHAFT END THRUST

Rocker arm bolts must be loosened sufficiently to free camshaft. Push camshaft toward rear of engine and install dial indicator so point is on camshaft sprocket attaching bolt. Zero indicator. Position screwdriver between camshaft sprocket or gear and block, pull camshaft forward and release. If end play is excessive, replace thrust plate.

NOTE — Do not attempt to pry camshaft back and forth with valve train load on camshaft.

CAM LOBE LIFT

Check lift of each camshaft lobe in consecutive order as follows:

- 1) Remove rocker arms and make sure each push rod is in valve lifter socket. Install dial indicator so ball socket adapter of indicator rests on end of push rod and in same plane as push rod movement.
- 2) With an auxiliary starter switch connected to starter solenoid and ignition switch off, bump crankshaft until tappet is on base circle of camshaft lobe. This is push rod's lowest point.
- 3) Zero dial indicator and continue to rotate crankshaft until push rod is in fully raised position (highest indicator reading). Compare total lift from indicator readings with specifications.
- 4) To check accuracy of dial indicator readings, continue to rotate crankshaft until indicator reads zero. If lift on any lobe is .005" less than specifications, valve lifters are operating on worn lobes.

ENGINE OILING

Crankcase Capacity — 4 qts., add 1 qt. with filter change.

Oil Filter — Replace at first oil change and every second oil change afterwards.

Normal Oil Pressure (Hot) — 40-60 psi at 2000 RPM.

Pressure Regulator Valve — In pump body. Not adjustable.

ENGINE OILING SYSTEM

Force feed with rotor type oil pump. All oil from pump flows through full flow oil filter before entering the engine. See Fig. 12. From oil filter, oil flows to main oil gallery located on right side of camshaft, lubricating engine components as follows:

Main Bearings — Oil from main gallery enters main bearings through drilled passages in block.

Camshaft Bearings — Passages are drilled from each main bearing to each camshaft bearing.

Timing Chain — Oil is forced through a drilled passage from oil pump intermediate shaft to groove in thrust plate and passes around camshaft. It then flows through two grooves in timing chain sprocket and is deflected onto the timing chain.

Connecting Rod Bearings — Crankshaft is drilled from main bearings to connecting rod bearings.

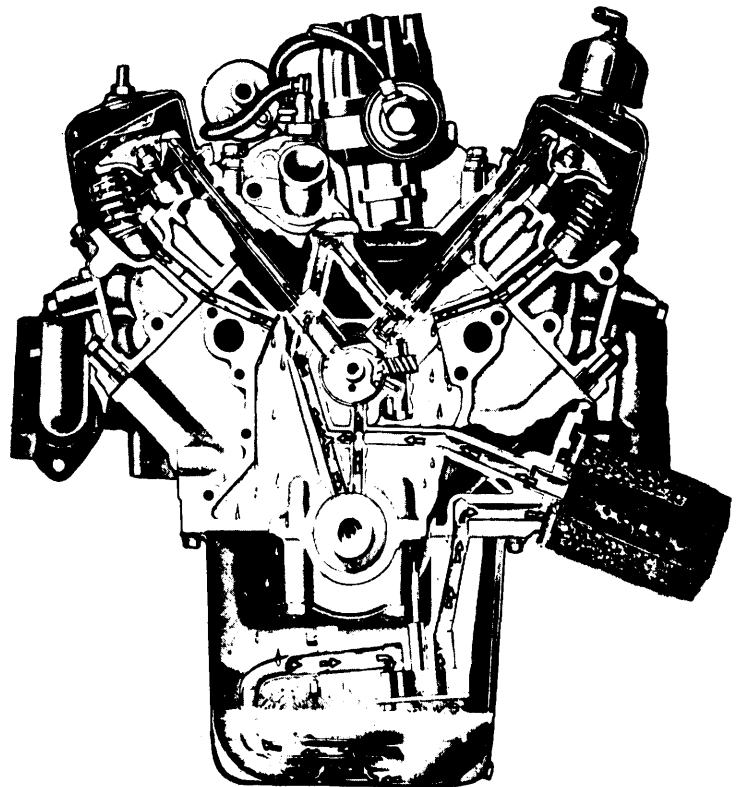

Fig.12 Engine Oiling Circuit

255", 302" & 351" V8 (Cont.)

Valve Lifters, Push Rods — Oil passages drilled from main oil gallery to each lifter gallery. Oil hole in valve lifter is indexed to lifter oil gallery and oil flows into lifter. Oil from lifter is metered through disc metering valve and flows up hollow push rod. Drilled hole in push rod is indexed to hole in rocker arm and oil lubricates the upper valve train and bearings. Excess oil is returned to oil pan through drain back holes at each end of cylinder head and block.

OIL PUMP

Disassembly — Remove oil inlet tube, cover bolts and cover from pump. Remove inner rotor and shaft assembly, then remove outer race. See Fig. 13. Drill a small hole and insert self-threading set metal screw into oil pressure relief cap and pull from chamber. Remove spring and plunger.

Reassembly — 1) Clean, inspect and oil all parts thoroughly. Install relief valve plunger, spring and new cap. Install outer race and inner rotor and shaft assembly.

NOTE — Identification mark (dimple) on outer race must face outward and on same side as identification mark on rotor. Rotor and shaft assembly and outer race are serviced as an assembly and both parts must be replaced together.

2) Install cover and tighten bolts. Install oil inlet tube on pump. Prime pump by filling either inlet or outlet port with oil and rotating pump shaft.

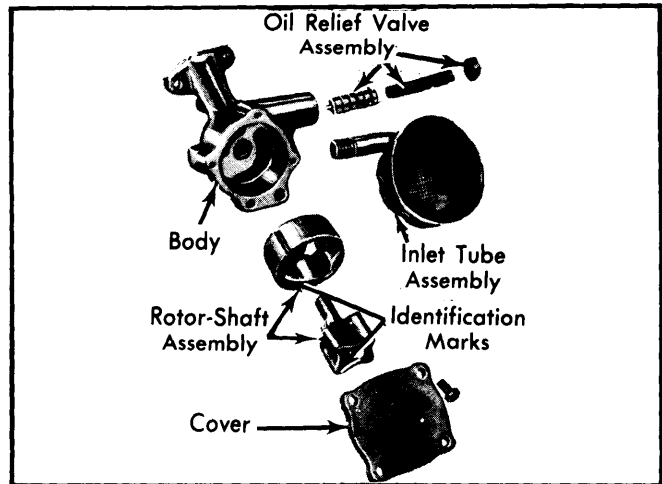

Fig. 13 Exploded View of Oil Pump Assembly

Oil Pump Specifications

Application	Clearance
Outer Race-to-Housing.....	.001-.013"
Rotor End Play.....	.004" Max.
Shaft-to-Housing0015-.0030"
Relief Valve-to-Bore.....	.0015-.0030"

Relief Valve Spring Specifications

Engine	Lbs. Pressure	Length
255" & 302"	10.6-12.2	1.704"
351"	18.2-20.2	2.490"

ENGINE SPECIFICATIONS

GENERAL SPECIFICATIONS						
Engine	Net HP At RPM	Torque (Ft. Lbs. at RPM)	Compr. Ratio	Bore	Stroke	Displ. Cu. Ins.
255"	122@3800	200@2200	8.8:1	3.68"	3.00"	255
302"	135@3600	240@1800	8.4:1	4.00"	3.00"	302
351"	149@3300	288@1800	8.3:1	4.00"	3.50"	351

VALVES							
Engine & Valve	Head Diam.	Face Angle	Seat Angle	Seat Width	Stem Diameter	Stem Clearance	Valve Lift
255" Int.	1.770"	44°	45°	.060-.080"	.3416-.3423"	.0010"	.3753"
Exh.	1.439"	44°	45°	.060-.080"	.3411-.3418"	.0015"	.3753"
302" Int.	1.770"	44°	45°	.060-.080"	.3416-.3423"	.0027"	.3753"
Exh.	1.463"	44°	45°	.060-.080"	.3411-.3418"	.0032"	.3909"
351" Int.	1.794"	44°	45°	.060-.080"	.3416-.3423"	.0010-.0027"	.4108"
Exh.	1.468"	44°	45°	.060-.080"	.3411-.3418"	.0015-.0032"	.4108"

Ford Motor Co. V8 Engines

255", 302" & 351" V8 (Cont.)

ENGINE SPECIFICATIONS (Cont.)

PISTONS, PINS, RINGS						
Engine	PISTONS	PINS		RINGS		
	Clearance	Piston Fit	Rod Fit	Rings	End Gap	Side Clearance
255"	.0018-.0026"	.0002-.0004"	Press Fit	Comp. Oil	.010-.020" .015-.055"	.002-.004" Snug
302"	.0018-.0026"	.0002-.0004"	Press Fit	Comp. Oil	.010-.020" .015-.055"	.002-.004" Snug
351"	.0018-.0026"	.0003-.0005"	Press Fit	Comp. Oil	.010-.020" .015-.055"	.002-.004" Snug

CRANKSHAFT MAIN & CONNECTING ROD BEARINGS							
Engine	MAIN BEARINGS				CONNECTING ROD BEARINGS		
	Journal Diam.	Clearance	Thrust Bearing	Crankshaft End Play	Journal Diam.	Clearance	Side Play
255"	2.2482-2.2490"	.0001-.0015"①	No. 3	.004-.008"	2.1228-2.1236"	.0008-.0015"	.010-.020"
302"	2.2482-2.2490"	.0001-.0015"①	No. 3	.004-.008"	2.1228-2.1236"	.0008-.0015"	.010-.020"
351"	2.9994-3.0002"	.0008-.0015"	No. 3	.004-.008"	2.3103-2.3111"	.0008-.0015"	.010-.020"

① — No. 1 bearing only. Others, .0004-.0015".

CAMSHAFT			
Engine	Journal Diam.	Clearance	Lobe Lift
255"			
Jrnl. 1	2.0805-2.0815"	.001-.003"	Int. .2375"
2	2.0655-2.0665"		Exh. .2375"
3	2.0505-2.0515"		
4	2.355-2.0365"		
5	2.0205-2.0215"		
302"	Same as 255"	.001-.003"	Int. .2375"
			Exh. .2475"
351"	Same as 255"	.001-.003"	Int. 2.600"
			Exh. 2.600"

VALVE SPRINGS			
Engine	Free Length	PRESSURE (LBS.)	
		Valve Closed	Valve Open
255"			
Int.	2.04"	74-82@1.78"	190-212@1.36"
Exh.	1.85"	76-84@1.60"	190-210@1.20"
302"			
Int.	2.04"	74-82@1.78"	196-212@1.36"
Exh.	1.85"	76-84@1.60"	190-210@1.20"
351"			
Int.	2.04"	74-82@1.78"	196-212@1.36"
Exh.	1.85"	76-84@1.60"	190-210@1.20"

TIGHTENING SPECIFICATIONS

Application	Ft. Lbs.
Cylinder Head	
255" & 302"	① 65-72
351" W	② 105-112
Oil Pan	9-11
Intake Manifold	23-25
Exhaust Manifold	18-24
Flywheel	75-85
Main Bearing Caps	
255" & 302"	60-70
351" W	95-105
Connecting Rods	
255" & 302"	19-24
351" W	40-45
Pulley-to-Damper	35-50
Damper-to-Crankshaft	70-90
Engine Front Cover	12-18
Camshaft Sprocket	40-45
Oil Pump	22-32
Water Pump	12-18

① — Torque in 2 steps: Step 1-(55-65); Step 2-(65-72).
 ② — Torque in 3 Steps: Step 1-(85); Step 2-(95); Step 3-(105-112).