

Propeller Shaft Alignment

PONTIAC PROPELLER SHAFT ALIGNMENT

Pontiac (Except Sunbird)

DESCRIPTION

Measurements of front and rear universal joint angles are accomplished by means of an inclinometer (J 23498 or J 22910) and adjustable length jounce pins (J 22910-2). These pins are mounted between top of axle housing and frame "kick-up" on both sides of vehicle, and are installed at a specific height to compensate for variables such as passenger load and weight in trunk, which would affect universal joint angles.

CHECKING & ADJUSTMENT

CHECKING

Lift and support vehicle at axle tubes. Install jounce pins as specified between axle tubes and frame. Frame must contact top of jounce pin. Add weight to rear of car if necessary to keep pins in place. Clean bearing cups, then measure universal joint angles as follows:

Front Universal Joint Angle — Place inclinometer on front propeller shaft bearing cup, center bubble in sight glass, and record angle. Rotate shaft 90°, mount inclinometer on front slip yoke bearing cup, center bubble in sight glass, and record angle. To obtain front universal joint angle, subtract smaller figure from larger figure.

Rear Universal Joint Angle — Place inclinometer on rear propeller shaft bearing cup. Center bubble in sight glass and record measurement. Rotate shaft 90°, then mount inclinometer on companion flange yoke bearing cup. Center bubble in sight glass and record angle. Subtract figures to obtain universal joint angle.

ADJUSTMENT

Front Universal Joint Angle — To correct angle between engine/transmission centerline and propeller shaft, add or remove shims between transmission rear bearing retainer and transmission mount. Addition of one shim to the transmission mount will decrease transmission joint angle by 1/2° and increase differential angle by 1/4°.

Rear Universal Joint Angle (Leaf Springs — Phoenix and Firebird) 1) Loosen "U" bolt nuts to three or four threads beyond bottom of bolts. Work on one side at a time. Install desired shim between upper spring plate cushion and spring.

2) Place thick end of shim toward front of vehicle to decrease angle. To increase angle, place thick end of shim toward rear of vehicle. Install spacers between upper and lower spring plates with thick end of spacer in same direction as shim. Tighten "U" bolt nuts to 45 ft. lbs.

Rear Universal Joint Angle (All Other Models) — To correct angle, rear control arms or bushings may need to be replaced. See *Pontiac Upper Control Arm and Lower Control Arm* in *SUSPENSION* Section.

Universal Joint Angles

Application (Jounce Pin Length)	Front	Rear
LeMans, Grand AM, Grand Prix Coupe & Sedan		
W/151" Engine (4.20")	1.3°	1.0°
W/O 151" Engine (4.96")	0.7°	1.3°
Wagon		
W/O 151" Engine (5.39")	0.3°	1.4°
Catalina, Bonneville		
7 1/2" Axle (4.96")	0.7°	1.3°
8 1/2" Axle (4.96")	0.7°	1.3°
8 3/4" Axle (5.39")	0.3°	1.4°
Firebird (5.20")	0.9°	3.8°
Phoenix (5.13")	0.6°	2.3°

NOTE — Vertical dimension is measured from top of axle tube to bottom surface of frame rail except on Phoenix. Top of axle tube to bottom of jounce restrictor bracket beneath frame rail is used for measurement on Phoenix.

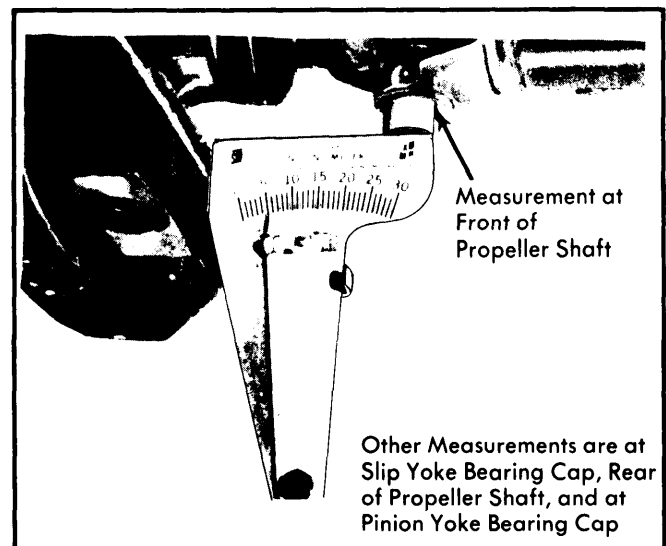

Fig. 1 Checking Universal Joint Angle