

Propeller Shaft Alignment

FORD MOTOR CO. PROPELLER SHAFT ALIGNMENT

Ford Motor Co.

DESCRIPTION

Pinion nose and propeller shaft angle are controlled by either a single rear suspension upper control arm on Ford, Mercury and Lincoln Continental, or by two lower control arms on all other models. Whenever control arm(s) are removed, pinion nose angle must be adjusted.

CHECKING & ADJUSTMENT

Checking - 1) Measure distance from top of axle housing to a point on frame rail adjacent to axle bumper rear bolt. Average measurements taken. Find rear suspension height as recorded in table. Position "V" magnet of Tool T68P-4602-A on drive shaft away from welds and balance weights.

2) From left side of vehicle, position tool on "V" magnet with adjusting screw to left. Adjust dial on tool until left side of bubble is on the zero line. Position tool on "U" joint bearing cap with tool in same relative position as it was on "V" magnet. Read position of bubble and compare to degree specifications recorded with those in table. If adjustment is necessary, adjust to specifications given in table.

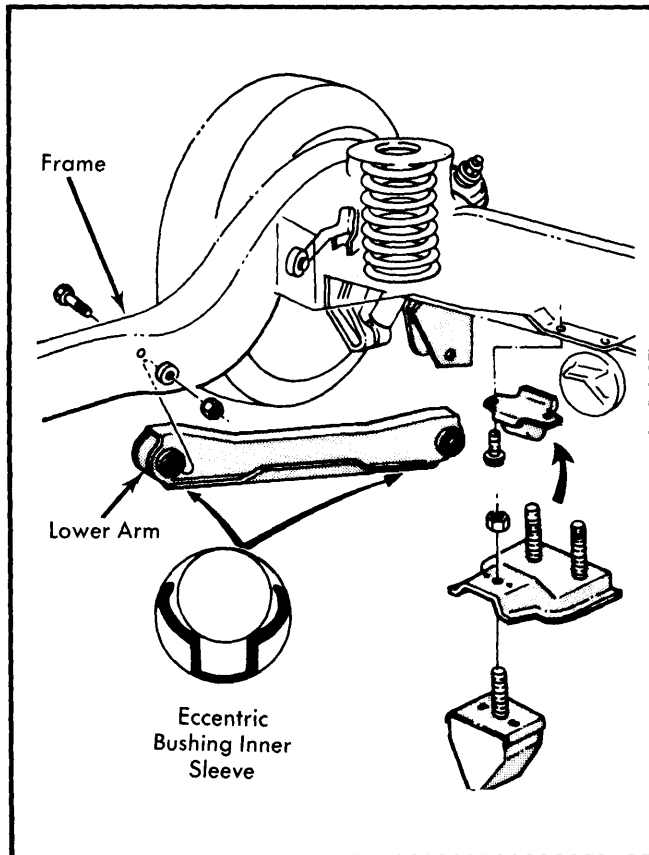

Fig. 1 Pinion Angle Adjustment on LTD II, Cougar, Thunderbird & Mark V

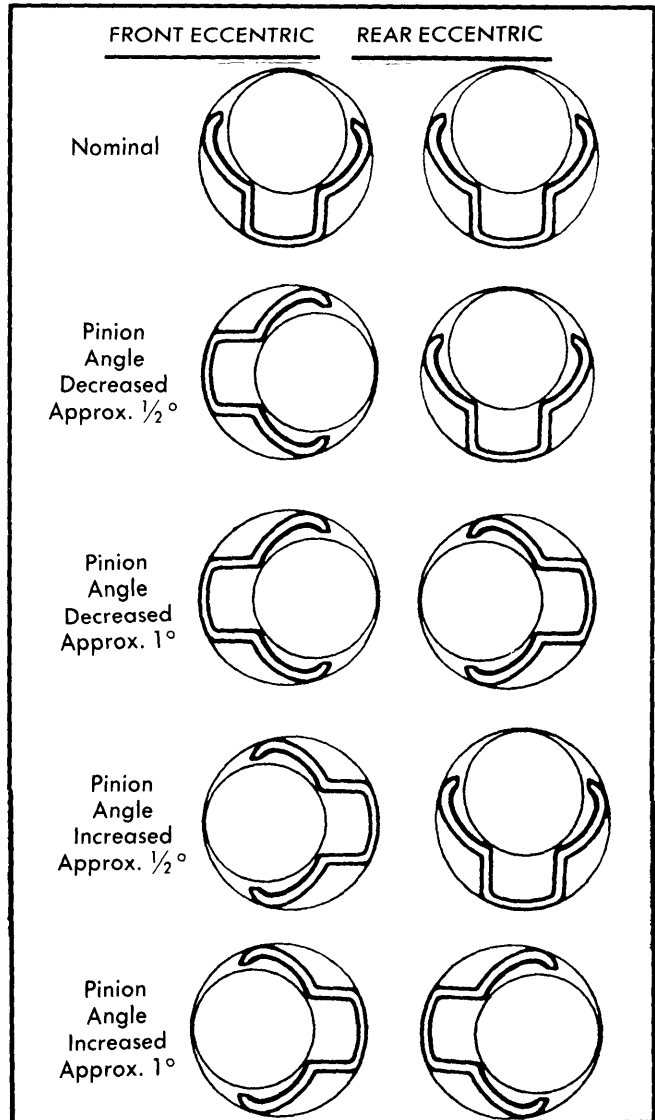

Fig. 2 Eccentric Bushing Inner Sleeve Positions

Adjustment (Single Upper Arm) - 1) If angle is not within specifications, upper arm-to-axle housing bolt and two eccentric washers form an adjusting cam mechanism which will tilt the axle housing to required angle.

2) At time of adjustment, replace pivot bolt, nut and lock washer and leave the nut loose. If angle is less than specification, rotate adjusting cam forward and check angle.

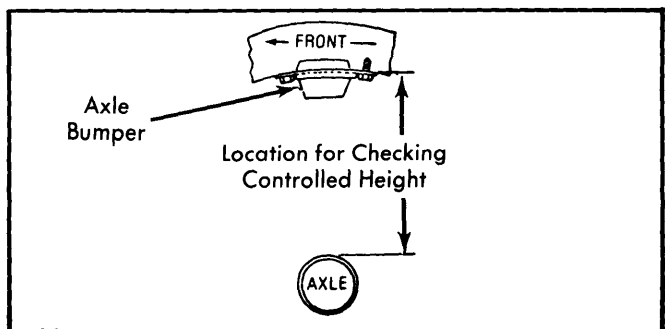

Fig. 3 Location for Measuring Control Height

FORD MOTOR CO. PROPELLER SHAFT ALIGNMENT (Cont.)

3) If angle is more than specified, rotate adjusting cam rearward and check the angle. When axle housing is adjusted to specifications, tighten pivot bolt and nut.

adjusting cams. When making adjustment on Mark V, install new non-serrated inner sleeve with adjusting cam.

Pinion Angle Degree & Controlled Height

Application	Degree	Controlled Height
Cougar & LTD II		
2 Door	2°33'±45'	4.82"
4 Door	2°28'±45'	4.82"
Station Wagon	1°7'±45'	4.82"
Ranchero	1°7'±45'	5.55"
Thunderbird	2°33'±45'	4.82"
Fairmont & Zephyr		
Sedan		
6¾" Axle	3°21'±30'	5.77"
7½" Axle	3°42'±30'	5.55"
Station Wagon		
6¾" Axle	3°10'±30'	6.10"
7½" Axle	3°30'±30'	5.88"
Mustang & Capri		
6¾" Axle	3°1'±30'	5.07"
7½" Axle	3°18'±30'	5.29"
Ford & Mercury		
Sedan		
7½" Axle	2°40'±30'	5.94"
8½" Axle	⓪2°28'±30'	5.94"
Station Wagon		
C-4 Trans.	3°8'±30'	6.38"
C-6 Trans.	2°59'±30'	6.38"
Mark V	2°47'+30' to -45'	4.82"
Lincoln	8°4'±50'	5.70"

⓪ - With C-6 Trans: 2°18'±30'

Adjustment (Double Upper Arm - Except Capri, Fairmont, Mustang & Zephyr) - 1) If angle is not within specifications, raise and support vehicle. Use a jack under the pinion housing to unload control arm bushings.

2) When making adjustment on LTD II, Cougar and Thunderbird, install new service arm kit. This kit includes new arms with

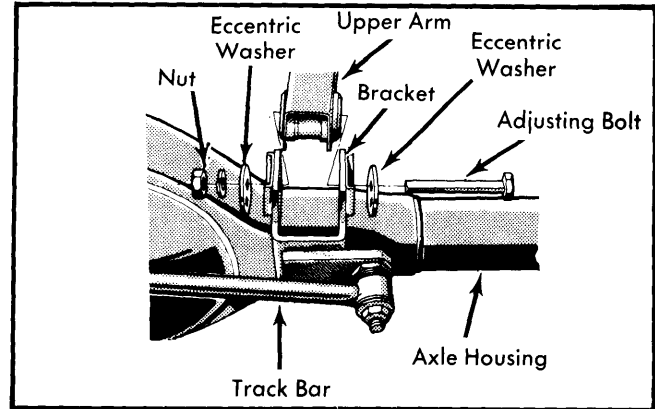

Fig. 4 Pinion Angle Adjustment

3) Use tool T72P-5538-A to rotate eccentric bushing which will raise or lower pinion nose angle to specifications. If further adjustment is required, use same procedure at rear end of arms. When adjustments have been completed, install new nuts and bolts.

Adjustment (Double Upper Arm - Capri, Fairmont, Mustang, & Zephyr) - 1) Remove upper arms and insert tool in eccentric inner sleeve (accessible through hole from which attaching bolt was removed). Rotate bushing to raise or lower pinion angle to specification.

2) Reinstall upper arms and install new pivot bolts and nuts with nut facing inboard. Recheck pinion angle and tighten pivot bolt with vehicle at controlled height.

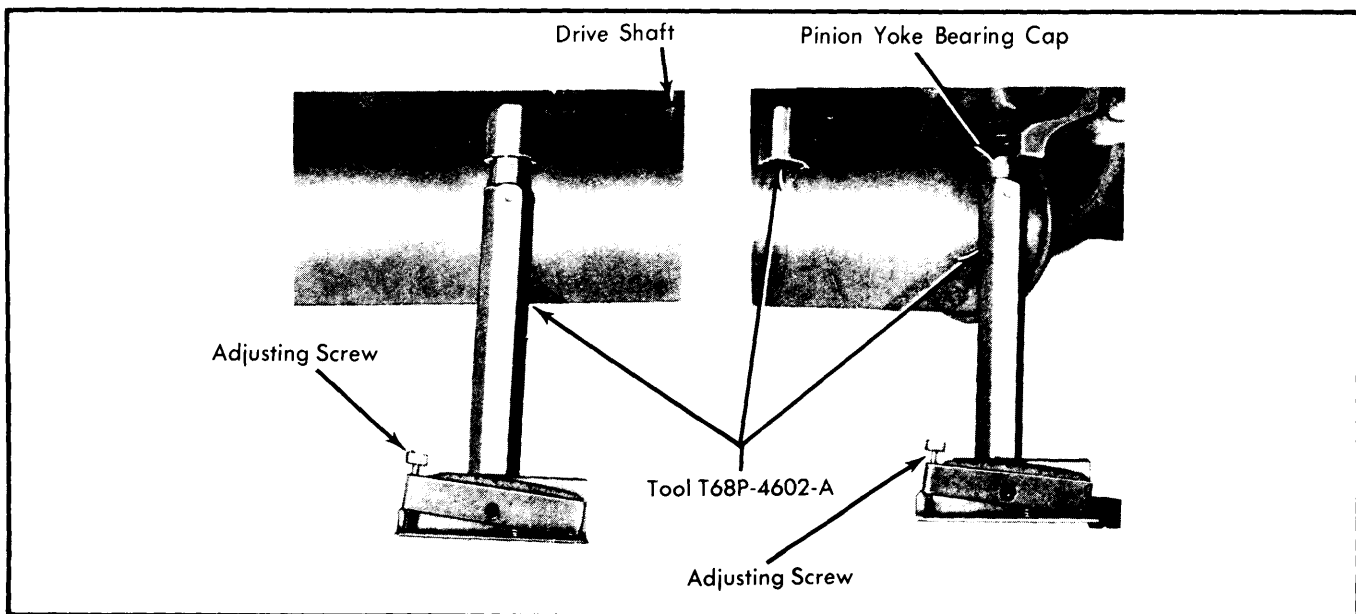

Fig. 5 Measuring Differential Nose Angle With Tool T68P-4602-A