

Drive Axles

FORD MOTOR CO. SEPARATE HOUSING

Ford Motor Co.
(Except Fairmont & Zephyr)

DESCRIPTION

Banjo type housing, semi-floating hypoid gear type, with centerline of pinion set below centerline of ring gear. Drive pinion and bearings are mounted in a pinion retainer, bolted to carrier. Removeable carrier is bolted to axle housing.

NOTE — Some models use other axles. See Ford Motor Co. Integral Housings in this section.

AXLE RATIO & IDENTIFICATION

Metal tag stamped with model designation and gear ratio is secured to one of carrier-to-housing bolts.

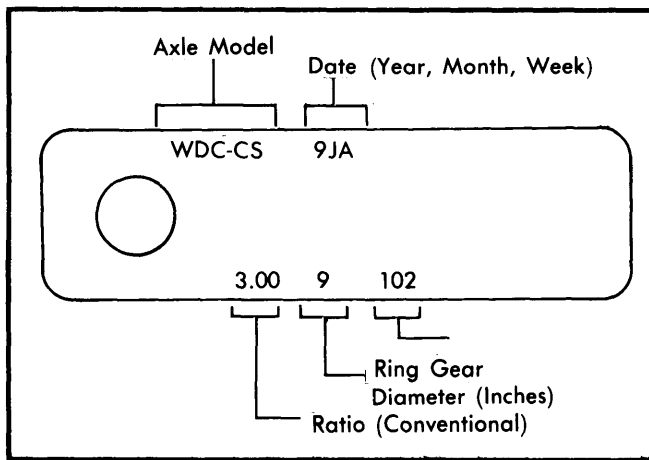

Fig. 1 Ford Motor Co. Rear Axle Identification Tag

Axle Ratio Identification

Application & Axle Ratio	Ring Gear Diameter	Code
Ford, Mercury		
2.75:1	9"	WFG-AA,WFG-BJ WFG-AL
3.00:1	9"	WFG-AL
Lincoln, Mark V		
2.50:1	9"	WGB-AB,WGC-K
2.75:1	9"	WV-T,WFY-A,
LTD II, Cougar, Thunderbird		
2.47:1	9"	WEB-BH,WFA-AU WFA-AS
2.50:1	9"	WEB-BF
2.75:1	9"	WEB-BM,WEB-BN, WFA-AL,WFA-AR WFA-AT

Axle Ratio Identification (Cont.)

Application & Axle Ratio	Ring Gear Diameter	Code
Bobcat, Capri, Granada, Monarch, Mustang, Pinto, Versailles		
2.50:1	9"	WFB-G,WFB-K
2.75:1	9"	WDX-E
2.79:1	8"	WDW-AB
3.00:1	8"	WDWZ,WDY-AA
3.40:1	8"	WDY-AH,WDY-S, WDY-W

NOTE — Code WF(x) axles have four pinion Traction-Lok differentials. All others have conventional two pinion differentials.

REMOVAL & INSTALLATION

AXLE SHAFTS & BEARINGS

Ball Bearing Axles — 1) Remove wheel and tire assembly, then remove brake drum. Work through hole in axle shaft to remove wheel bearing retaining nuts. Pull axle shaft with suitable adapter and slide hammer. Remove backing plate and secure it to frame.

2) Nick bearing retainer with a chisel to loosen it for removal from shaft. (On Ford and Mercury, drill a 1/4" hole in the retainer ring surface before using a chisel.) Remove bearing with suitable tool and arbor press. Remove seal from housing with reverse hammer and adapter.

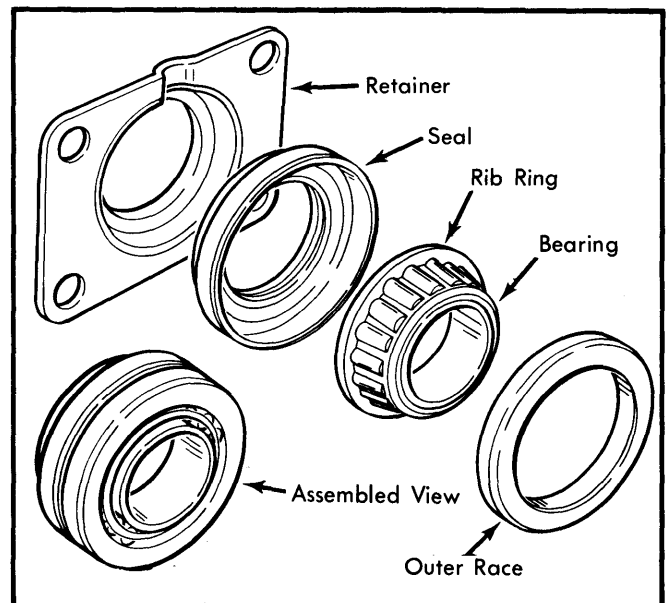

Fig. 2 Tapered Roller Bearing Assembly

FORD MOTOR CO. SEPARATE HOUSING (Cont.)

3) Apply oil resistant sealer to OUTSIDE of new seal and install in housing. Place bearing retainer plate on axle shaft and press bearing on shaft. Using same tools as for removal, press retainer on shaft until seated firmly against bearing. Do not press bearing and retainer on shaft at the same time.

NOTE — Lubricated seal assembly used on drum brake vehicles is of a different length than that used on rear disc brake equipped vehicles. They are NOT interchangeable. Drum brake seals have a gray metal appearance while those used with disc brakes have a black oxide appearance.

Tapered Roller Bearing Axles (Drum Brakes) — 1) Remove brake drum, after removing necessary brake components. Working through hole in axle shaft flange, remove axle shaft retainer nuts. Using a slide hammer type puller, remove axle shaft and then bearing race from axle housing.

2) Drill a 1/4" hole in outside diameter of inner retainer, approximately three-quarters of thickness of ring. Place chisel across drilled hole and strike sharply to break ring. Using a press and suitable adapters, remove bearing from shaft.

3) Install outer retainer plate (if removed) on axle shaft. Place lubricated seal and bearing on axle shaft, making sure bearing race rib is facing axle flange. Press tapered bearing onto axle shaft and then install axle shaft.

NOTE — Roller bearing removal on disc brake rear axle may use the same procedure as used for drum brake rear axle if suitable tools (T75L-1165-C, T76P-1165-E & T75L-1165-B) are not available.

Tapered Roller Bearing Axles (Disc Brakes) — 1) Remove disc brake rotor, after removing necessary brake components. Working through hole in axle shaft flange, remove axle shaft retainer nuts. Using a slide hammer type puller, remove axle shaft and then bearing race from axle housing.

2) Place outer bearing race back on axle shaft assembly. Remove bearing retainer from axle shaft. Install tube (T75L-1165-C) over axle shaft. Slide remover tool (T76P-1165-E) over tube and install bolts to attach caliper anchor plate.

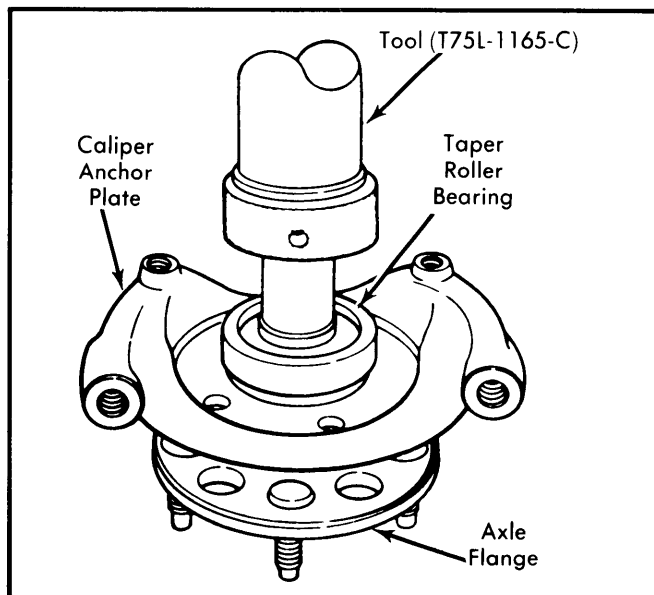

Fig. 3 Removal of Axle Bearing

3) Install service plate (T75L-1165-B) over tube (T75L-1165-C) and screw knurled ring onto tube to retain service plate. Using an arbor press, press axle shaft from removal assembly. To install, reverse removal procedure.

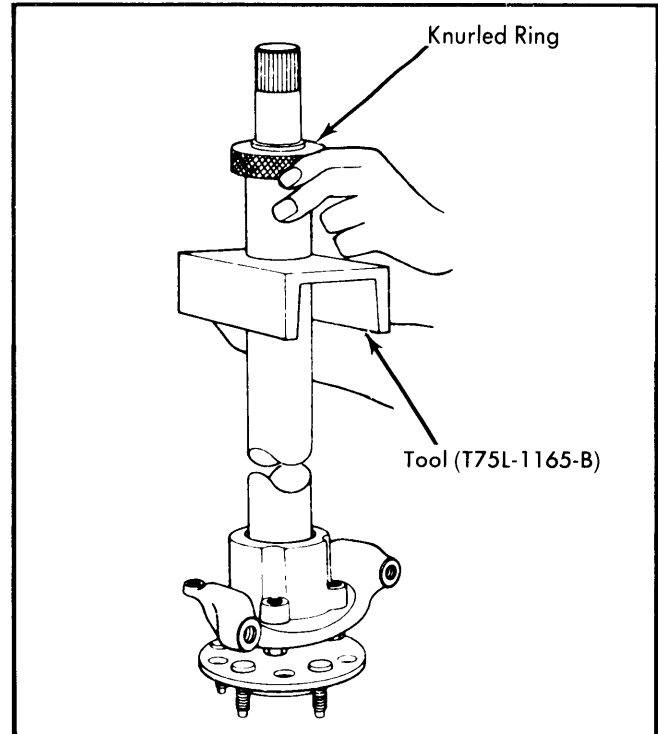

Fig. 4 Installation of Axle Bearing Service Tool

PINION FLANGE & OIL SEAL

With Collapsible Spacer — 1) Disconnect propeller shaft, then mark pinion nut, pinion shaft and companion flange for reassembly reference. Using an INCH lb. torque wrench on pinion nut, record torque required to rotate pinion shaft through several revolutions.

2) Using suitable tools, remove pinion nut, washer, flange and oil seal. Install new oil seal, then apply lubricant to flange splines. Install flange, washer and new nut. Tighten pinion nut until original preload is obtained.

NOTE — Rotate pinion shaft occasionally to insure seated bearings.

3) If recorded preload is less than desired preload (see specifications), continue tightening nut until desired preload is obtained.

CAUTION — Do not back off pinion nut to lessen preload. If this is done, a new spacer must be installed.

DIFFERENTIAL CARRIER

Remove propeller shaft and axle shafts. Place a drain pan under axle to catch lubricant, remove carrier attaching bolts, then remove carrier. To install, reverse removal procedure and tighten carrier attaching bolts.

OVERHAUL

NOTE — Special tool sets are available for servicing rear axle assemblies. Be sure to use suitable tools which will properly remove and install axle parts without distortion or damage.

FORD MOTOR CO. SEPARATE HOUSING (Cont.)

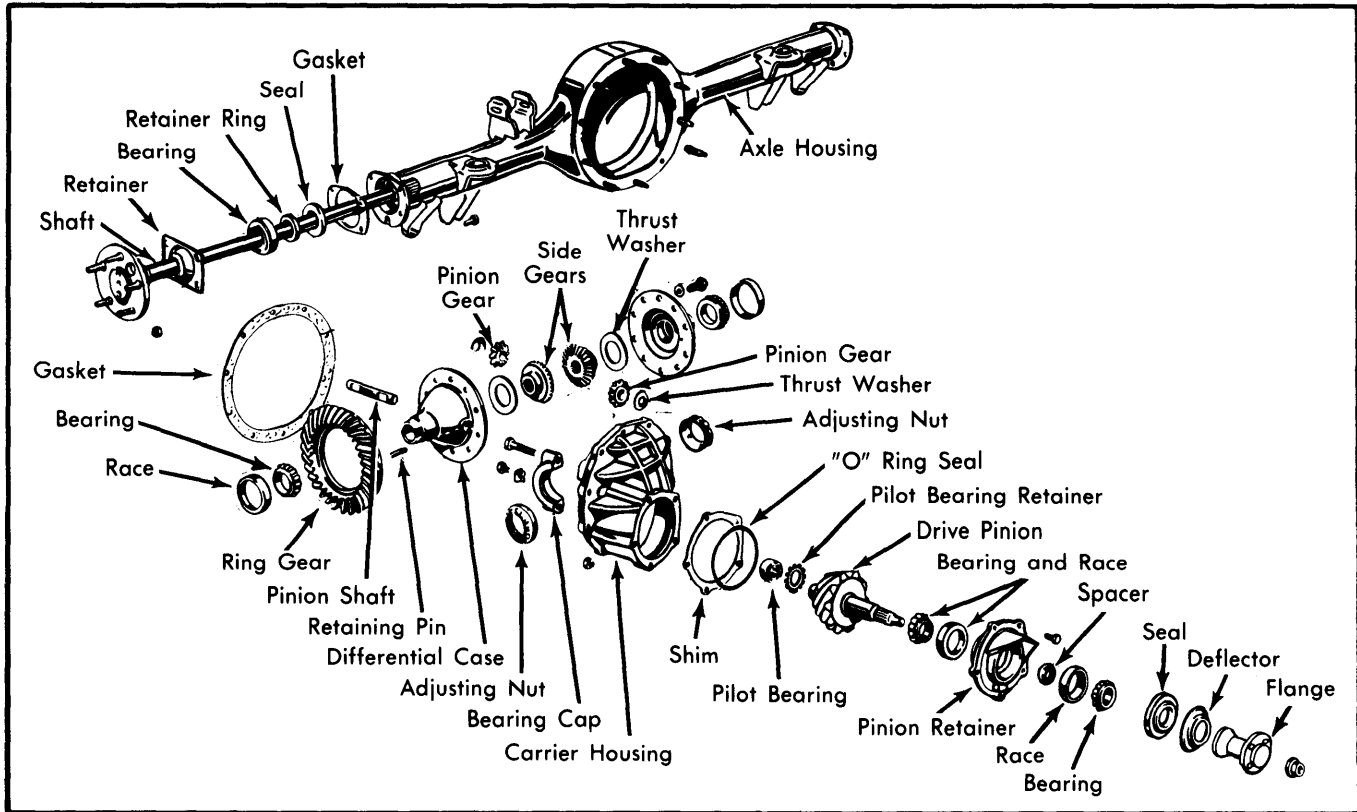

Fig. 5 Exploded View of Ford Motor Co. Separate Housing Axle Assembly

DISASSEMBLY

1) Mark differential bearing caps for reassembly reference, then remove caps, adjusting nut locks, and adjusting nuts. Remove differential assembly from carrier, then remove side bearings from case, if required, using suitable puller.

2) Remove ring gear attaching bolts and tap ring gear from case. Separate case, then drive out pinion shaft retaining pin. Drive out pinion shaft with a brass drift, then remove side gears, pinions and thrust washers.

3) Remove pinion nut, companion flange and seal, then remove pinion retainer from housing. Measure and record shim thickness with a micrometer for reassembly reference.

4) Using a suitable press, press pinion shaft out of front and rear bearing cones. Remove pilot bearing, if required, by driving bearing and retainer toward front of carrier housing.

NOTE — Do not remove cups from retainer unless they are worn or damaged. If cups are replaced, cone and roller assemblies should also be replaced.

REASSEMBLY

1) Assemble rear bearing, collapsible spacer, retainer and front bearing in order on pinion shaft. Press assembly into position using caution not to crush spacer. Lubricate and install "O" ring into groove in pinion retainer.

2) Drive pilot bearing inward until it bottoms and install new retainer, concave side out. Place proper shim on carrier housing and install pinion and retainer assembly. Install and tighten attaching bolts.

3) Place slinger over pinion shaft and against front bearing. Install new seal, flange and integral nut and washer. Hold flange and tighten pinion nut to no more than 175 ft. lbs.

4) Use INCH lb. torque wrench and note torque required to rotate pinion through several revolutions. If less than desired, tighten nut a little at a time until proper preload is obtained. See Fig. 6.

CAUTION — Do not overtighten nut. If excessive preload is obtained, replace collapsible spacer. Do not back off nut to lessen preload. If torque on pinion nut is less than 175 ft. lbs. after bearing preload is established, a new collapsible spacer must be installed.

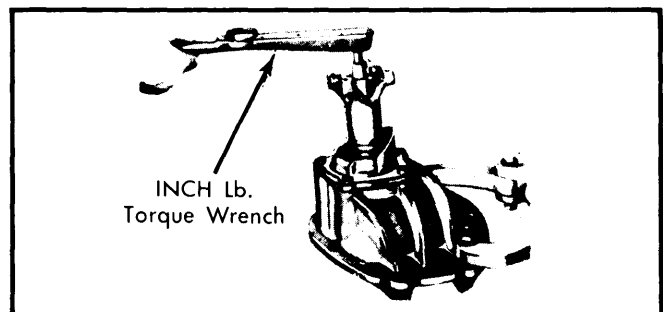

Fig. 6 Checking Pinion Bearing Preload

Differential Reassembly — 1) Lubricate all parts with rear axle lubricant. Place a side gear and thrust washer in differential case bore, then install pinion shaft into case only far enough to retain thrust washer and pinion gear.

FORD MOTOR CO. SEPARATE HOUSING (Cont.)

2) Install second pinion gear and thrust washer. Drive pinion shaft into place, making sure pinion shaft lock holes are aligned. Install second side gear and thrust washer into position, then install cover on differential case.

3) Insure free rotation of assembly and install pinion shaft lock pin. Position ring gear on case and tighten ring gear attaching bolts evenly. Replace differential side bearings if removed.

Installation - 1) Wipe a thin coat of lubricant on bearing bores so bearing cups will slide easily. Place cups on differential side bearings, then install differential into carrier.

NOTE - Be sure to align index marks on ring gear and pinion, if equipped.

2) Slide assembly along bores until a slight amount of backlash is felt between gears. Install adjusting nuts in bores so that they just contact bearing cups.

3) Install bearing caps and bolts, then tighten bolts alternately, making sure adjusting nuts turn freely. Loosen cap bolts then tighten to 25 ft. lbs., and make backlash and preload adjustments.

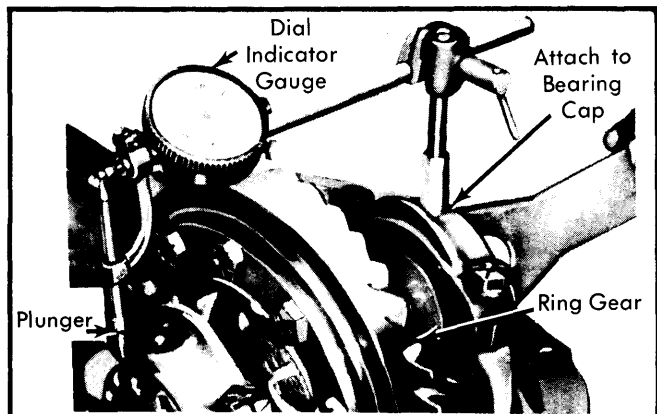

Fig. 7 Dial Indicator Installed to Check Case Spread for Preload

ADJUSTMENT

NOTE - Left adjusting nut is on ring gear side of carrier, right nut is on pinion side.

Backlash & Side Bearing Preload - 1) Loosen right nut until it is away from bearing cup. Tighten left nut until ring gear is just forced into pinion with no backlash, then rotate pinion to make sure there is no binding. Recheck right nut at this time to make sure it is still loose.

NOTE - Tightening left nut moves ring gear into pinion to decrease backlash, tightening right nut move ring gear away.

2) Install a dial indicator as shown in illustration. Tighten right nut until it first contacts bearing cup, then preload bearings from .008-.012" case spread. Rotate pinion gear several times in each direction to seat bearings.

3) Tighten differential bearing cap bolts. Measure backlash at several teeth around ring gear. If backlash is not within specifications, loosen one nut and tighten opposite nut an equal amount, to move ring gear away from or toward pinion gear.

NOTE - When moving adjusting nuts, final movement should always be in a tightening direction.

4) Recheck differential bearing preload, then make a gear tooth pattern check to insure correct assembly. Shim thickness between carrier housing and pinion retainer may be decreased to set pinion closer to ring gear. A thicker shim will move pinion away from ring gear. Recheck backlash and preload.

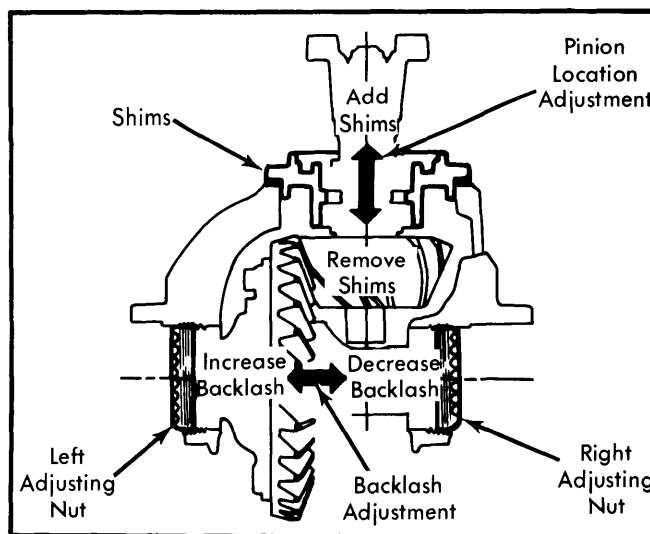

Fig. 8 Ring & Pinion Gear Adjustments

ADJUSTMENT SPECIFICATIONS

Application	Inches
Ring Gear Backface Runout003
Side Gear Thrust Washer Thickness.....	.030-.032
Pinion Gear Thrust Washer Thickness.....	.030-.032
Differential Bearing Preload	
New008-.012
Used005-.008
Nominal Pinion Shim Thickness	
8 Inch Ring Gear.....	.022
9 Inch Ring Gear.....	.015
Ring Gear-to-Pinion Backlash008-.012
Maximum Backlash Variation Between Teeth003

TIGHTENING SPECIFICATIONS

Application	Ft. Lbs.
Bearing Cap Bolt.....	70-85
Bearing Adjusting Lock Nut Bolt.....	12-25
Carrier-to-Housing Stud Nuts	25-40
Pinion Retainer-to-Carrier Bolts	30-45
Ring Gear Attaching Bolts	70-85
Minimum Torque-to-Tighten Pinion Nut	
For Pinion Bearing Preload	
All with Collapsible Spacer	① 170
Pinion Bearing Preload	
All with Collapsible Spacer... (New)@	17-27 INCH Lbs.
(Used)@	8-14 INCH Lbs.

① - If preload exceeds specification before this torque is obtained, install a new spacer.

② - With oil seal.