

Engine Cooling Systems

GENERAL COOLING SYSTEM SERVICING (Cont.)

pump to about seven psi. Race engine, if needle on dial fluctuates it indicates a combustion leak.

CAUTION — Pressure may build up fast. Release any excess pressure above the upper limit of pressure cap specifications or cooling system damage may result.

If needle does not fluctuate, race engine a few more times and check for water at tail pipe. Excessive water would indicate a faulty head gasket, cracked block or cylinder head near ex-

haust ports. Next, remove oil dipstick and if water globules appear in the oil, a serious internal leak is indicated.

ANTI-FREEZE CONCENTRATION

Test anti-freeze concentration using a suitable anti-freeze tester. The tester should have a temperature compensating feature, as failing to take temperature into consideration could cause an error as large as 30°F. Follow tester manufacturer's instructions for correct use of tester.

COOLANT RECOVERY SYSTEMS

American Motors
Chrysler Corp.
Ford Motor Co.
General Motors

DESCRIPTION

A coolant recovery system differs from other cooling systems in that an overflow bottle is connected to the radiator overflow hose. The overflow bottle is transparent or translucent to permit checking of coolant level without removing radiator cap. No adjustment or test is required except keeping vent hole or hose clean and checking pressure relief of radiator cap.

OPERATION

As coolant temperature rises and pressure in system exceeds pressure relief valve of radiator cap, due to expansion of coolant, excess coolant flows into overflow bottle. As engine cools and coolant contracts, vacuum is formed in system, drawing coolant, stored in overflow bottle, back into radiator. As a result, in a properly maintained cooling system, the only coolant losses will be through evaporation.

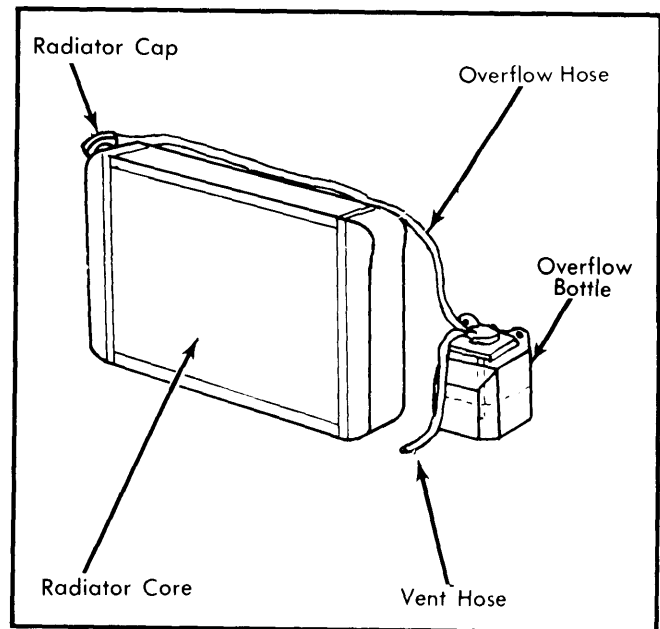

Fig. 4 Coolant Recovery System

THERMOSTATICALLY CONTROLLED ELECTRIC FAN

Chrysler Corp.
Horizon
Omni

DESCRIPTION

The electrically-driven fan is actuated by the radiator fan switch, which automatically shuts off fan motor when it is not needed (on Non-A/C vehicles). On air conditioned vehicles, the switch shuts off the fan when air conditioning is turned off, turns it on when the system is operating.

The 14-inch, 6-bladed fan is driven by either a 5 ampere electric motor (Non A/C) or a 10 ampere motor (A/C vehicles).

The motor runs only when the coolant temperature at the radiator fan switch reaches 193-207° F or whenever the air conditioner is operating. The motor also shuts off when the ignition switch is turned off, regardless of coolant temperature.

TESTING

If fan is not operating properly, disconnect fan motor wire connector, and connect it with 14 gauge wire to a good 12-volt

battery. If fan runs, motor is all right, indicating either car battery may be at fault, radiator fan switch is defective, or electric fan relay (A/C vehicles only) may be inoperative. If fan motor does not run when connected directly to a good battery, replace fan motor.

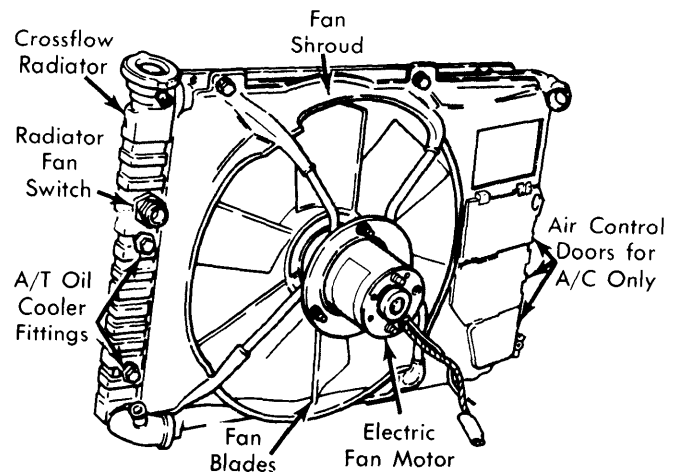

Fig. 5 Thermostatically Controlled Electric Fan