

260", 350" VIN CODES B & R & 403" V8 ENGINES

IDENTIFICATION CODING

ENGINE IDENTIFICATION

Engines may be identified by code letter appearing below and as the fifth digit of the Vehicle Identification Number located on left upper instrument panel. Code letters also appear on a code tape located on left front valve cover of Oldsmobile and Pontiac engines and on front left side of Buick cylinder blocks.

Application	VIN Code
260" 2-Bbl. (LV8)	F
350" 4-Bbl. (L34)	R
350" E.F.I.Ⓢ	B
403" 4-Bbl. (L80)	K

Ⓢ — Electronic Fuel Injection.

ENGINE REMOVAL

See *Engine Removal at end of ENGINE Section.*

CYLINDER HEAD & MANIFOLDS

INTAKE MANIFOLD

Removal — Drain radiator and remove air cleaner assembly. Disconnect all coolant hoses to manifold, throttle cable, fuel and vacuum lines. Remove temperature gauge wires and disconnect or remove alternator and A/C compressor brackets, as necessary. Remove bolts and lift off intake manifold assembly from engine with carburetor attached.

Installation — Clean all gasket surfaces. Coat both sides of new intake manifold gasket with sealer and install gasket on head. Install end seals, being sure that end of seals are positioned under edges of heads. Install manifold. Dip bolts in engine oil before installing. Install and tighten bolts in two steps in sequence shown in *Fig. 1.*

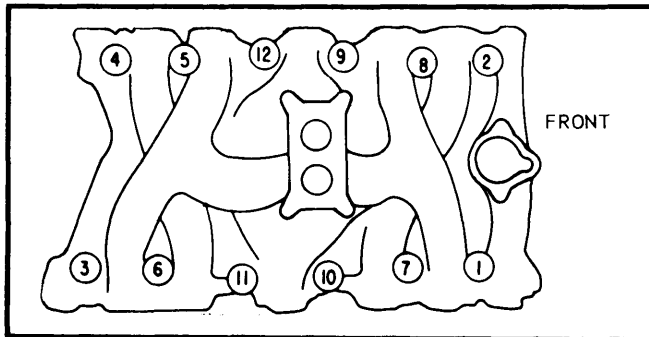

Fig. 1 Intake Manifold Tightening Sequence

CYLINDER HEAD

Removal — 1) Drain cooling system. Block may be sufficiently drained by raising rear wheels 24". Remove intake and exhaust manifolds. Remove valve cover, rocker arm bolts, pivots, rocker arms and push rods.

NOTE — Keep components separate for reinstallation in original location.

2) Loosen or remove any accessory brackets which interfere. Disconnect ground strap. Remove bolts and cylinder head.

Installation — Clean all gasket surfaces. Gaskets are of composition type and must be installed **WITHOUT** sealer. Install gaskets with colored stripe facing upward. Install cylinder heads. Dip head bolts in engine oil, install and tighten in two steps in sequence shown in *Fig. 2.*

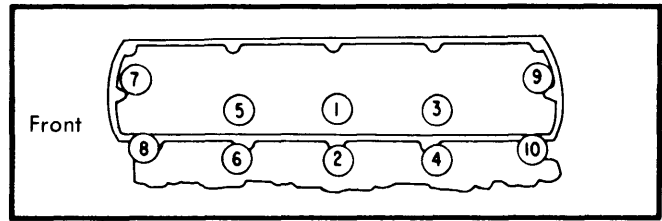

Fig. 2 Cylinder Head Tightening Sequence

VALVES

VALVE ARRANGEMENT

I-E-I-E-E-I-E-I (both banks, front to rear).

VALVE GUIDE SERVICING

Guides are integral with cylinder head. If stem-to-guide clearance is excessive, replace valve. Some valves with oversize stems are used in production, and can be identified by marks on inboard side of cylinder head on machined surface just above intake manifold. Valve guide reamers are available in .003", .005" and .013" oversize. When reconditioning, always use next oversize reamer and replacement valve. Service valves are available in standard, .003", .005", .010", and .013" oversizes.

VALVE STEM OIL SEALS

Cup type seals are used on all valves. Using suitable tool (BT-6804), install seals with cupped side down toward cylinder head. Position seals down as far as possible on valve stems. Seals will correctly position themselves when engine is started. See *Fig. 3.*

Valve Seal Identification

Stem Diameters	Intake Seal Color	Exhaust Seal Color
Standard to .005"		
Oversize	Gray	Ivory
.010" to .013"		
Oversize	Orange	Blue

General Motors V8 Engines

260", 350" VIN CODES B & R & 403" V8 ENGINES (Cont.)

VALVE SPRINGS

Removal — Remove rocker arm cover, spark plug and rocker arm assemblies on cylinder(s) to be serviced. Install air line adapter (BT-72-1B) to spark plug port and apply air to hold valves in place. Using suitable tools (BT-6413 and BT-6412), compress valve spring and remove valve keys, rotators, and springs. If spring is off square more than $\frac{1}{16}$ ", replace spring.

Installation — Reverse removal procedure and ensure that valve keys are securely locked in groove of valve stem.

VALVE STEM INSTALLED HEIGHT

To measure valve stem height, place suitable tool (BT-6428 or J-25289) over installed valve stem and measure clearance between gauge and stem. Clearance should be at least .015". Remove valve and grind tip of stem (to a 90° end), if clearance is less than specified. With valve keys installed on valves, tap all valve stem ends with a hammer to seat valve retainers (or rotator) and keys. Remeasure clearance between retainer (or rotator) and gauge. If any valve stem end is less than .005" above rotator or .030" above retainer, valve is too short and must be replaced.

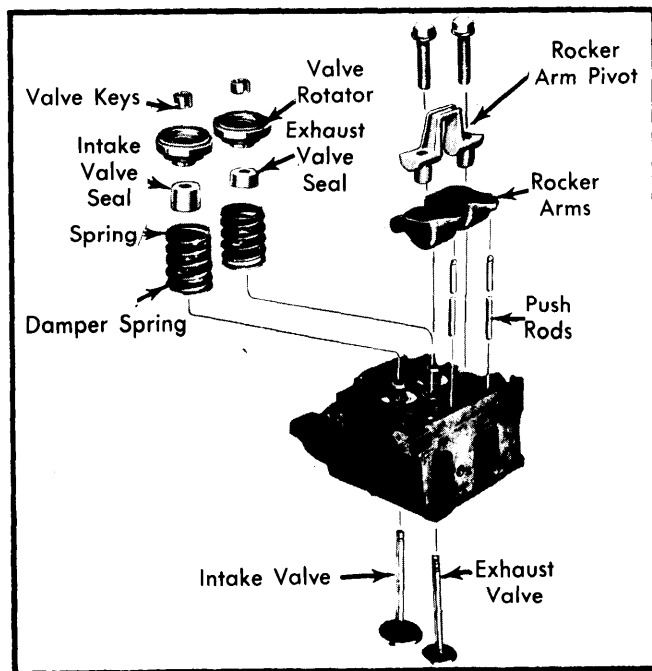

Fig. 3 Rocker Arm & Valve Assemblies

ROCKER ARM ASSEMBLY

Friction surfaces of rocker arms and pivots must be coated with a suitable lubricant upon reassembly and installed in original locations. Tighten hardened flanged bolts alternately to prevent breaking pivots.

HYDRAULIC VALVE LIFTER ASSEMBLY

1) Using suitable tool (BT-6407), remove valve lifter assemblies. Keep in sequence for installation in original location. Some engines have both standard and .010" oversize lifters. Oversize is etched "O" on side of lifter and cylinder block. Inspect all components for nicks, burrs or scoring of parts.

2) If either body or plunger is defective, replace with new lifter assembly. Check lifter foot for wear by placing straightedge across foot. Replace any lifter showing concave surface wear.

Leakdown Testing — Lifter must be assembled while submerged in test fluid. Proceed as follows:

1) Install suitable adapter tool (BT-105-2) in reservoir of suitable leakdown tester (BT-60) and fill reservoir with test fluid (BT-59) to $\frac{1}{2}$ " below top of reservoir. Assemble ball check, ball check spring and retainer in plunger with flange pressed tight against bottom of recess in plunger. See Fig. 4.

2) Install plunger spring over retainer. Hold plunger with the spring up and insert into lifter body (to prevent cocking spring). Place assembly in tester cup and position push rod seat into plunger. Position $\frac{1}{4}$ " steel test ball on push rod seat and lower tester ram until it contacts steel ball. Allow ram to move downward by its own weight until air bubbles disappear. Repeat several times until all air is expelled from lifter.

CAUTION — Do not attempt to expel the air from lifters by pumping the ram.

3) After air is removed, allow ram to bleed down lifter to expose ring groove. Install retaining ring. Adjust ram screw so it contacts steel ball in push rod seat when pointer is at start line. Raise arm and start test by resting ram on steel ball.

4) Rotate reservoir one revolution every two seconds, and time indicator from start line to stop line. Allowable leakdown time is 6 seconds for used lifters and 12-87 seconds for new lifters.

NOTE — If lifter is within specifications, place in service without removing test fluid.

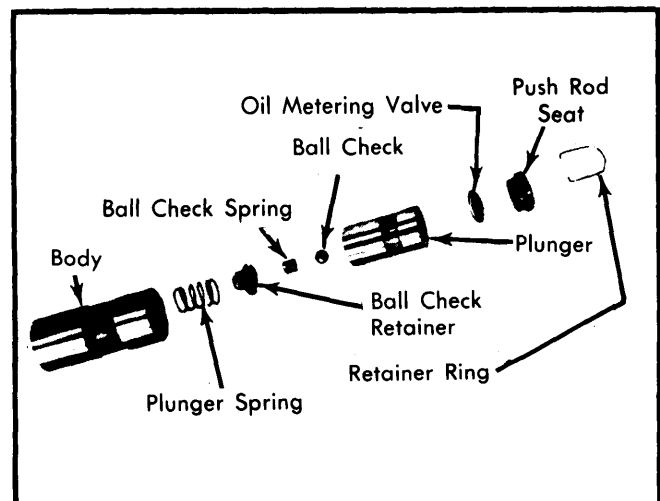

Fig. 4 Hydraulic Valve Lifter Assembly

260", 350" VIN CODES B & R & 403" V8 ENGINES (Cont.)

PISTONS, PINS & RINGS

OIL PAN

See *Oil Pan Removal* at end of *ENGINE* Section.

PISTON & ROD ASSEMBLY

Removal — 1) With oil pan, oil pump and cylinder head removed, use a suitable ridge reamer to remove any ridge or deposits on upper end of cylinder bore.

NOTE — Piston must be at bottom of stroke and covered with cloth to collect cuttings.

2) Inspect connecting rods and caps for cylinder identification and mark as necessary. Remove rod cap and install a short piece of $\frac{3}{8}$ " hose over connecting rod studs. Push piston and rod assembly out top of cylinder block. Remove other piston and rod assemblies in same manner.

Installation — Lightly coat pistons, rings and cylinder walls with engine oil. Install ring compressor on piston and install piston and rod assembly in its respective cylinder bore with notch on piston head facing front of engine. Guide connecting rod onto crankshaft journal while tapping piston head with hammer handle to seat connecting rod against crankshaft. Install mating rod cap and tighten rod cap nuts.

FITTING PISTONS

When measuring piston for size or taper, measurement must be made on skirt 90° from piston pin hole (with piston pin removed). The largest reading must be taken at bottom of skirt. Maximum allowable taper is .000-.0001". Measure cylinder bores with inside micrometer or cylinder gauge 90° to crankshaft. Maximum allowable bore taper is .001".

PISTON PINS

Using components from tool set J-24608, remove and install piston pin. See Fig. 5. Coat piston pin bore with oil before pressing pin into place. Press pin in until it contacts stop.

NOTE — Connecting rods may have either side up when installing piston and pin. Notch on piston should face front of engine when installed. Some vehicles may have .010" oversize pistons.

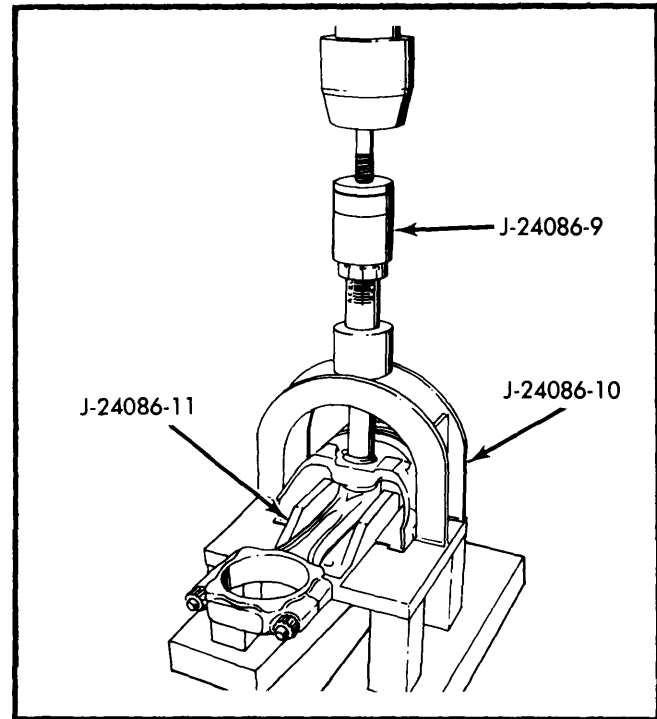

Fig. 5 Piston Pin Removal & Installation

CRANKSHAFT & ROD BEARINGS

MAIN & CONNECTING ROD BEARINGS

NOTE — Following procedures are performed with oil pan and oil pump removed.

Connecting Rod Bearings — After ensuring rod caps are marked for cylinder identification, remove rod caps. Use Plastigage method to check for proper bearing clearances. If not within specifications, new bearings must be installed. Bearings may be installed without removing piston and rod from engine. Check connecting rod journals for .0015" maximum out of round. Coat bearing surfaces with oil, install rod cap and tighten nuts. Check between connecting rods for .006-.020" side clearance.

NOTE — Tang on bearing half must fit with notch on rod cap and connecting rod.

Main Bearings — 1) Support crankshaft at both front and rear and ensure that all bearing caps, other than one being checked, are tight. Starting with rear main bearing cap and working forward, remove one cap at a time and check bearing clearances using Plastigage method. Maximum permissible journal out-of-round is .0015".

NOTE — When replacing bearings, loosen all main bearing caps. Never use shims. Always install bearing halves in pairs. Never use an old bearing teamed with a new one.

260", 350" VIN CODES B & R & 403" V8 ENGINES (Cont.)

2) To replace upper main bearing half, insert a flattened cotter pin or roll pin in oil passage hole in crankshaft and rotate crankshaft in direction opposite to cranking rotation. Place new upper bearing half on crankshaft journal with locating tang in correct position. Rotate shaft to turn bearing into place using tool as in removal. Tighten all main bearing cap bolts and rotate crankshaft. Be sure there is no drag. See Fig. 6.

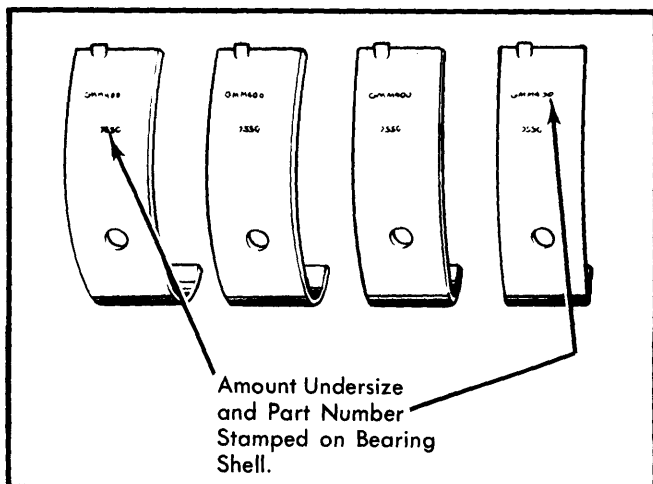

Fig. 6 Main Bearing Identification

REAR MAIN BEARING OIL SEAL

Repair & Installation – 1) Drain crankcase, remove oil pan and rear bearing cap. Using packing tool (BT-6433), gently drive old seal into groove until it is packed tight. This may vary from $\frac{1}{4}$ " to $\frac{3}{4}$ " depending on amount of pack required. Repeat on other end of seal in block.

2) Measure amount seal was driven up on one side, add $\frac{1}{16}$ ", then cut this length from old seal removed from bearing cap. Place a drop of sealer on each end of seal and work these two pieces into cylinder block with two small screwdrivers. Pack these short pieces into block using packing tool. Trim excess packing flush with block. Form a new rope seal in bearing cap. Install cap bolts and torque to specifications.

CAMSHAFT

ENGINE FRONT COVER

Removal – Drain cooling system and disconnect all coolant hoses. Remove radiator upper support and radiator. Remove all belts, fan and fan pulley, crankshaft pulley and hub. Remove oil pan. Remove cover, timing indicator and water pump assembly.

Installation – Install new cover gasket with suitable sealer around water holes. Position on block. Install front cover, new front seal, timing indicator and water pump assembly. Apply engine oil to front cover bolts, install and tighten.

FRONT COVER OIL SEAL

Removal – With crankshaft pulley and pulley hub removed, remove seal with puller tool (BT-6406).

Installation – Apply sealer to outside diameter of new seal. Using seal installer tool (BT-6405), install oil seal in front cover. Tighten until a .005" feeler gauge just fits between tool and front cover. Install pulley hub and crankshaft pulley. Install and adjust belts.

TIMING CHAIN

Removal – Remove front cover, fuel pump eccentric and oil slinger. Remove camshaft sprocket and timing chain. Remove crankshaft sprocket key and then crankshaft sprocket.

NOTE – Crankshaft sprocket may have to be removed with a puller.

Installation – 1) Position crankshaft so keyway points halfway between 1 o'clock and 2 o'clock positions. Install timing chain and sprockets together and align timing marks. See Fig. 7.

NOTE – When two marks are in alignment, number six piston is at TDC. To obtain TDC for number one cylinder, rotate crankshaft one revolution. This will bring camshaft sprocket mark to the top and number one piston will be in firing position.

2) Install fuel pump eccentric with flat side rearward. Drive crankshaft sprocket key in with a brass hammer until it bottoms.

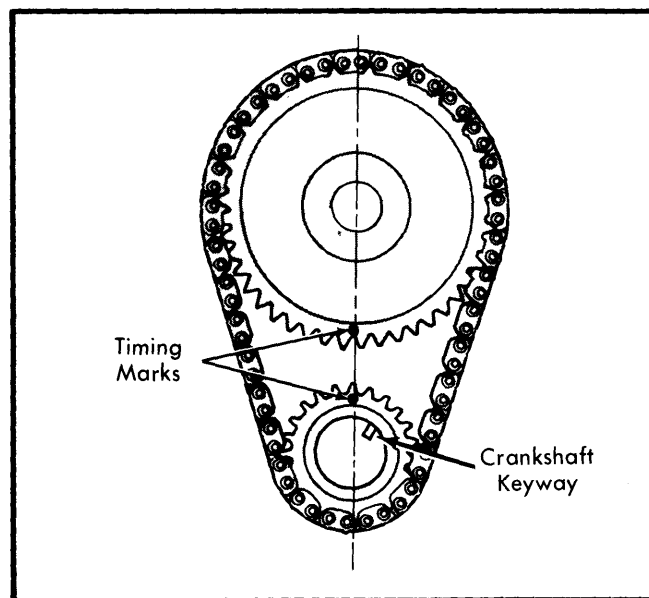

Fig. 7 Timing Chain Sprocket Alignment

CAMSHAFT

Removal – 1) Disconnect battery and drain radiator. Remove upper radiator baffle, radiator hoses and support clamp. Disconnect transmission oil cooler lines at radiator. Remove radiator fan shroud and radiator. Disconnect fuel line at fuel pump.

2) Remove air cleaner and disconnect throttle cable. Remove alternator drive belt. Remove alternator mounting bracket

260", 350" VIN CODES B & R & 403" V8 ENGINES (Cont.)

bolts and place alternator aside. Remove power steering mounting bolts and move pump clear of engine.

3) Remove air conditioning compressor mounting bolts and water pump by-pass hose, electrical and vacuum connections. Remove distributor complete with cap and wiring. Raise vehicle and drain engine oil.

4) Remove crankshaft pulley, pulley hub and front cover. Remove valve covers. Remove intake manifold, gasket, front and rear seals, rocker arms, push rods and lifters.

NOTE — Keep parts in order for reassembly.

5) Discharge air conditioning system and remove condenser (if equipped). Remove fuel pump eccentric and attaching bolt, camshaft gear, oil slinger and timing chain. Carefully slide camshaft out of front of engine.

Installation — To install camshaft, reverse the removal procedure.

NOTE — Before installation, coat camshaft and bearings liberally with suitable lubricant.

CAMSHAFT BEARINGS

Removal — Bearings must be replaced as a complete set. Using suitable tool (BT-6409) remove bearings in order (No. 1 first, No. 2 second, etc.).

Installation — To install camshaft bearings, reverse removal procedure while noting the following: To aid in aligning bearings with oil passages, place bearing in front bore with tapered edge toward block and align oil hole in bearing with center of oil slot in bore. Mark top of bearing. When installing bearing, mark will act as a guide.

VALVE TIMING

1) Remove distributor cap, right valve cover, No. 4 cylinder intake and exhaust rocker arms and pivot. Remove wire from "BAT" terminal at distributor. Turn ignition switch on and crank engine until rotor is in line with No. 4 spark plug wire position (No. 4 piston at top of cylinder).

2) Measure from pivot boss on head surface to top of No. 4 intake push rod and record measurement. Crank engine until rotor approaches No. 1 spark plug wire position. Continue to turn engine until timing mark on crankshaft pulley is at TDC. Measure from pivot boss surface to top of No. 4 intake push rod. Measurement should increase over first recorded measurement by $\frac{3}{32}$ " to $\frac{5}{32}$ ".

ENGINE OILING

Crankcase Capacity — 4 quarts Exc. Toronado ; 5 quarts Toronado. Add 1 quart with filter change.

Oil Filter — Replace filter at first oil change and every second oil change after that.

Normal Oil Pressure — 35 psi at 1500-3000 RPM.

Pressure Regulator Valve — Located in oil pump cover. Not adjustable.

ENGINE OILING SYSTEM

Oil pump is mounted on rear main bearing cap in crankcase with full flow filter on right side of crankcase. Oil from filter flows through passages at rear of block to rear end of right main oil gallery and through "V" passage at front of engine to left main oil gallery. See Fig. 9. Oil distribution is as follows:

Crankshaft & Camshaft Bearings — Rear crankshaft and camshaft bearings are lubricated by a vertical passage intersecting horizontal cross passage from oil filter. Other crankshaft and camshaft bearings are lubricated by a "V" shaped oil passage in each crankcase web.

Valve Lifters — Each lifter supplied with oil through short passage leading upward from right and left main galleries at point directly below lifter.

Rocker Arms, Push Rods & Valves — Hollow push rods are supplied with oil through hole in valve lifter push rod seat.

Distributor Drive Gear — Lubricated from drilled hole in plug at rear end of left main oil gallery.

Timing Chain & Sprockets — Lubricated from drilled hole in hexagonal headed plug which closes front end of right main oil gallery.

OIL PUMP

Located on rear main bearing cap. Do not remove drive shaft extension washers (serviced as a unit). Pressure relief valve clearance in bore should be .0025-.005". End clearance of gears should be .0015-.0085". See Fig. 8.

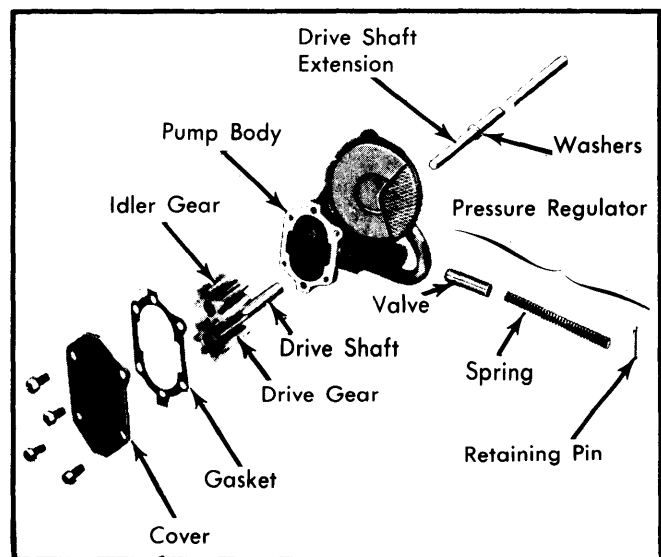

Fig. 8 Oil Pump Assembly

General Motors V8 Engines

260", 350" VIN CODES B & R & 403" V8 ENGINES (Cont.)

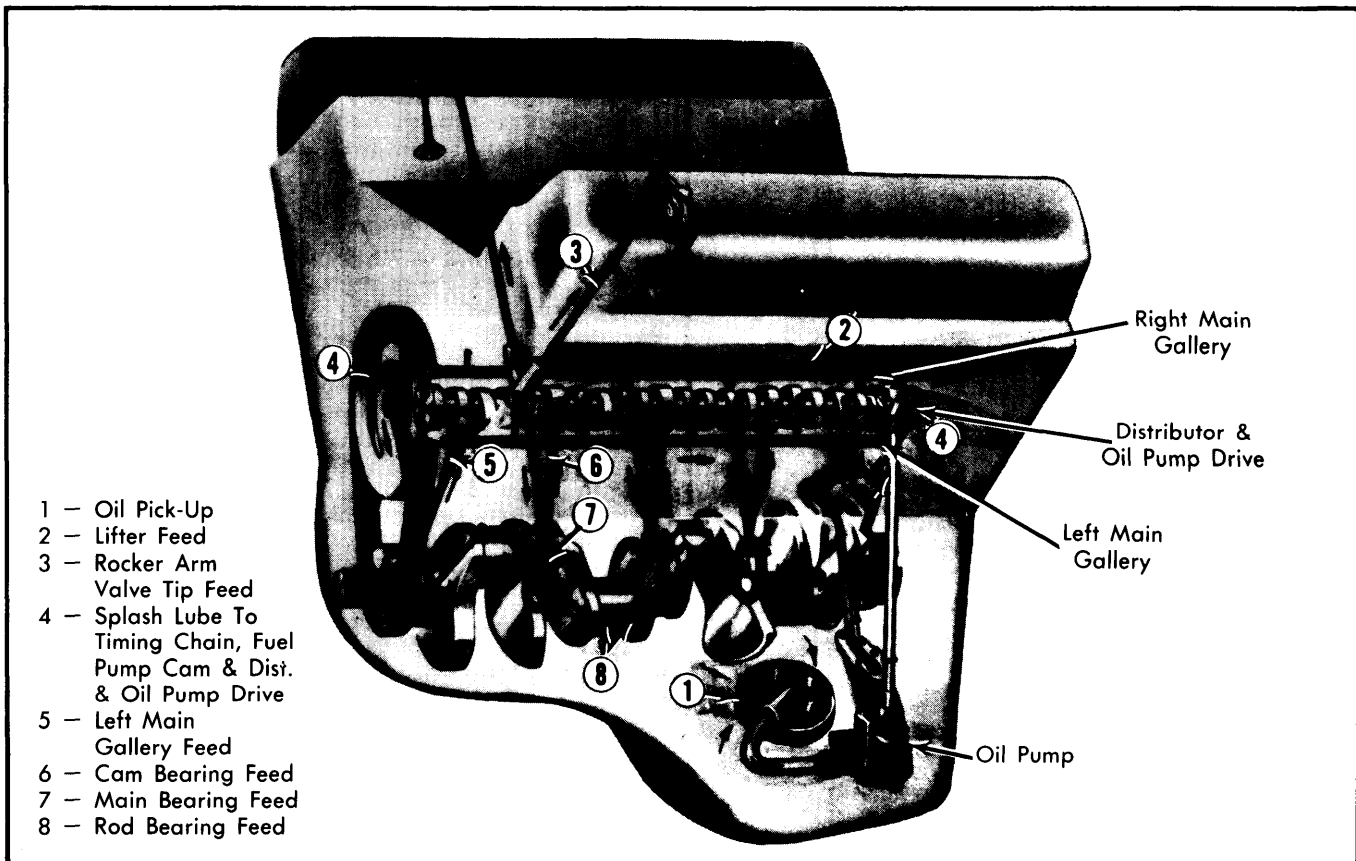

Fig. 9 Engine Oiling System

ENGINE SPECIFICATIONS

GENERAL SPECIFICATIONS						
Engine	Net HP At RPM	Torque (Ft. Lbs. at RPM)	Compr. Ratio	Bore	Stroke	Displ. Cu. Ins.
260"	105 @ 3600	205 @ 1800	8.0-1	8.0-1	3.385"	260
350"	160 @ 3600	270 @ 2000	8.5-1	8.5-1	3.385"	350
403"	175 @ 3600	310 @ 2000	8.5-1	8.3-1	3.385"	403

VALVES							
Engine & Valve	Head Diam. ①	Face Angle	Seat Angle	Seat Width	Stem Diameter	Stem Clearance	Valve Lift
260"							
Int.	1.522"	44°	45°	.037-.075"	.3425-.3432"	.0010-.0027"
Exh.	1.300"	30°	31°	.050-.090"	.3420-.3427"	.0015-.0032"
350"							
Int.	1.875"	44°	45°	.037-.075"	.3425-.3432"	.0010-.0027"
Exh.	1.502"	30°	31°	.050-.090"	.3420-.3427"	.0015-.0032"
403"							
Int.	1.995"	44°	45°	.037-.075"	.3425-.3432"	.0010-.0027"
Exh.	1.502"	30°	31°	.050-.090"	.3420-.3427"	.0015-.0032"

① - Diameter is $\pm .005$ ".

General Motors V8 Engines

6-111

260", 350" VIN CODES B & R & 403" V8 ENGINES (Cont.)

ENGINE SPECIFICATIONS (Cont.)

PISTONS, PINS, RINGS						
Engine	PISTONS Clearance	PINS		RINGS		
		Piston Fit	⓪Rod Fit	Rings	End Gap	Side Clearance
260", 350", & 403"	②.0008-.002"	.0003-.0005"	.0008-.0018"	No. 1	③.009-.019"	.0020-.0040"
				No. 2	③.009-.019"	.0020-.0040"
				No. 3	.015-.055"

- ⓪ — Press fit.
- ② — 403" engine is .0005-.0015".
- ③ — 350" engine is .010-.020".

CRANKSHAFT MAIN & CONNECTING ROD BEARINGS							
Engine	MAIN BEARINGS				CONNECTING ROD BEARINGS		
	Journal Diam.	Clearance	Thrust Bearing	Crankshaft End Play	Journal Diam.	Clearance	Side Play ^⓪
260", 350" & 403"	②2.4985-2.4995"	③.0005-.0021"	No. 3	.004-.008"	2.18-2.1248"	.0004-.0033"	.006-.020"

- ⓪ — Total of 2 rods.
- ② — No. 1 journal diameter is 2.4988-2.4998".
- ③ — No. 5 bearing clearance is .0015-.0031".

VALVE SPRINGS			
Engine	Free Length	PRESSURE (LBS.)	
		Valve Closed	Valve Open
260", 350" & 403"	1.96"	76-84 @ 1.670"	180-194 @ 1.270"

CAMSHAFT			
Engine	Journal Diam.	Clearance ^⓪	Lobe Lift
All	②2.0357-2.0365"	.0020-.0058"

- ⓪ — End play is .011-.077".
- ② — No. 1 Journal. Each succeeding journal is .020" small than preceding journal.

TIGHTENING SPECIFICATIONS

Application	Ft. Lbs.	Application	Ft. Lbs.
Cylinder Head		Engine Front Cover	
260"	①85	3/8" Bolts	35
350" & 403"	②130	Toronado	45
Intake Manifold	③40	Water Pump-to-Front Cover	13
Exhaust Manifold	25	Rocker Arm Pivot Bolts to Head	28
Main Bearings		Rocker Arm Cover	④
All Except Rear	80	Fuel Pump-to-Block	25
Rear Only	120	Fuel Pump Eccentric-to-Camshaft	65
Connecting Rod Caps	42	Engine Mounts-to-Engine	75
Balancer-to-Crankshaft Bolt	200-310	① — Tighten in two steps to 60 and 85 ft. lbs.	
Oil Pump-to-Bearing Cap	35	② — Tighten in two steps to 100 and 130 ft. lbs.	
Oil Pump Cover	8	③ — Tighten in two steps to 15 and 40 ft. lbs.	
Oil Pan	10	④ — Fully driven, seated, not stripped.	