

151" 4 CYL.

IDENTIFICATION CODING

ENGINE IDENTIFICATION

Engine can be identified by fifth digit of Vehicle Identification Number, located on a plate attached to left upper side of instrument panel and visible through windshield. Engines are also stamped with a production code number for emissions equipment identification. Code is stamped on pad behind distributor shaft on VIN 1 engines or on upper left front corner of block above water pump on VIN V or 9 engines.

Engine	VIN Code
151" (2.5L)	
Calif. W/O Crossflow Head (LS6)	1
Calif. W/ Crossflow Head (LS8)	9
Fed. W/ Crossflow Head (LX8)	V

ENGINE REMOVAL

See *Engine Removal* at end of ENGINE Section.

CYLINDER HEAD & MANIFOLDS

INTAKE & EXHAUST MANIFOLDS (VIN 1)

Removal - 1) Remove inlet ducts and air cleaner. Disconnect all lines, wiring and linkage to manifolds. Remove carburetor and heat shield.

2) Disconnect exhaust pipe at flange. Unbolt manifold-to-head attachments. Remove intake and exhaust manifolds as an assembly.

NOTE - It may be necessary to remove generator rear bracket to clear manifold assembly.

3) Disconnect EGR pipe and remove 4 bolts at center of assembly to separate manifolds.

NOTE - Use new gasket between manifolds for assembly. Install gasket with perforated side toward intake. To avoid cracking manifold when installing on engine, use following procedure: Install 4 bolts loosely, place manifolds on straight, flat surface and torque to specifications. This will align mating surfaces of manifolds and head.

Installation - 1) Position manifold assembly on cylinder head, ensuring that guides are properly located. Finger tighten all bolts.

2) Tighten manifold-to-cylinder head bolts following torque sequence. See Fig. 1. Reverse removal procedure to complete installation.

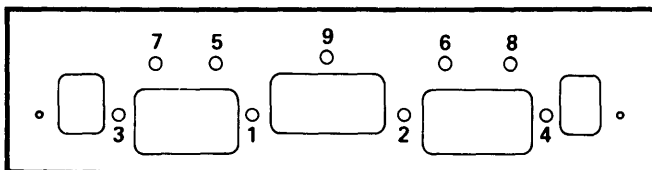

Fig. 1 Intake Manifold Tightening Sequence (VIN 1)

INTAKE MANIFOLD (VIN V & 9)

Removal - 1) Drain coolant. Remove air cleaner and all lines, wiring and linkage to manifold. Remove carburetor.

2) Remove alternator and/or A/C bracket. Unbolt and remove manifold.

Installation - 1) Position manifold and gasket on head. Finger tighten all bolts.

2) Torque manifold-to-cylinder head bolts following torque sequence. See Fig. 2. Reverse removal procedure to complete installation.

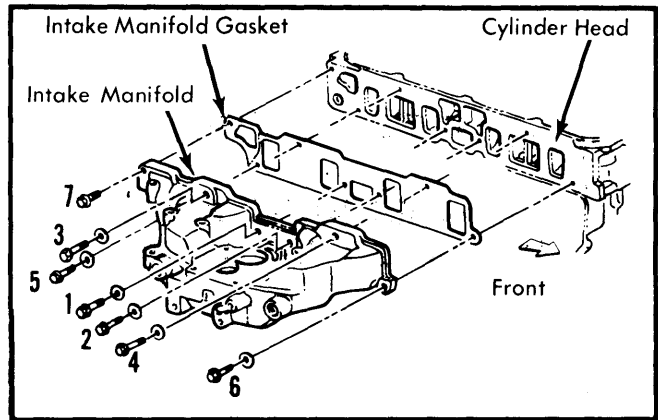

Fig. 2 Intake Manifold Tightening Sequence (VIN V & 9)

EXHAUST MANIFOLD (VIN V & 9)

Removal - 1) Remove air cleaner and pre-heat tube. Disconnect exhaust pipe from manifold.

2) Remove dipstick bracket bolt. Unbolt and remove manifold.

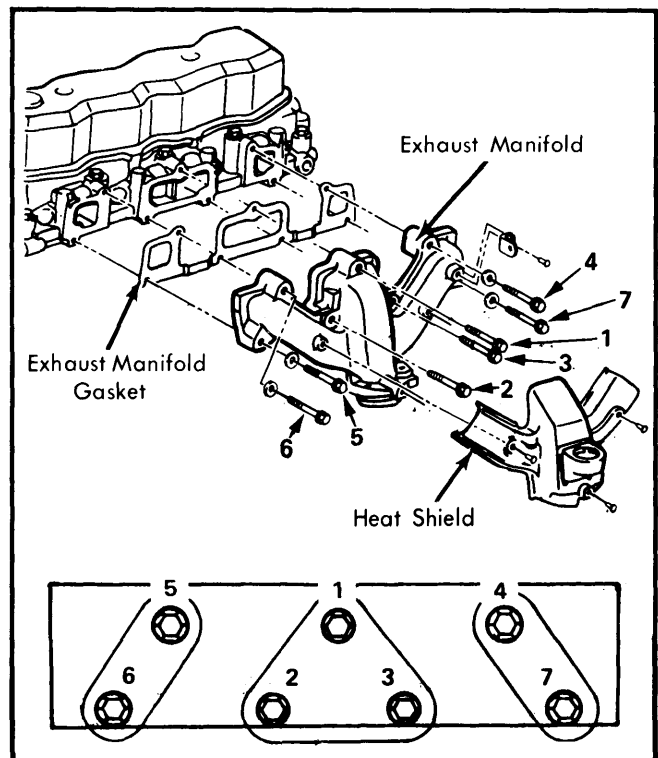

Fig. 3 Exhaust Manifold Tightening Sequence (VIN V & 9)

151" 4 CYL. (Cont.)

Installation – 1) Position manifold and gasket on head. Finger tighten all bolts.

2) Torque manifold-to-cylinder head bolts in sequence. See Fig. 3. Reverse removal procedure to complete installation.

CYLINDER HEAD

Removal – 1) Remove air cleaner and drain cooling system. Remove intake and exhaust manifolds. Disconnect all wiring, lines, linkage and cables to manifolds and head.

2) Remove alternator, A/C and power steering brackets. Disconnect all hoses at cylinder head and remove spark plugs.

3) Remove rocker arm cover and loosen rocker arm nuts. Remove push rods. Remove cylinder head bolts and remove head and gasket.

Installation – 1) Position new cylinder head gasket over dowel pins in block. Install cylinder head. Using approved sealing compound, coat threads and heads of cylinder head bolts and install finger tight.

2) Torque head bolts to specifications gradually. Follow tightening sequence shown in Fig. 4. Reverse removal procedure to complete installation.

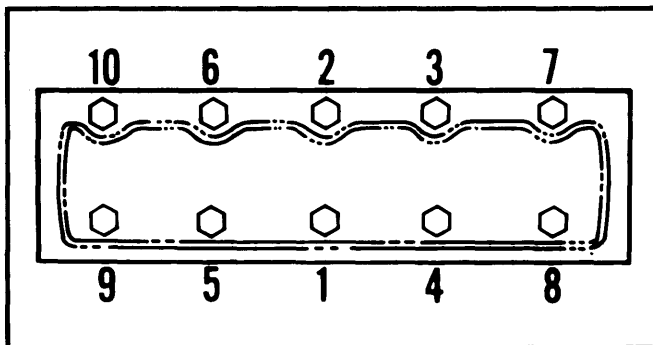

Fig. 4 Cylinder Head Tightening Sequence

VALVES

VALVE ARRANGEMENT

VIN 1 – E-I-I-E-E-I-I-E

VIN V & 9 – I-E-I-E-E-I-E-I

VALVE GUIDE SERVICING

Guides are integral with cylinder head. If valve guide-to-stem clearance is excessive, valves with oversize stems are available. Ream valve guide bores in steps to obtain proper valve stem to valve guide clearance.

VALVE STEM OIL SEALS

Oil seals are used on all valve stems and should be replaced whenever valve spring is removed or valve service is performed.

VALVE SPRINGS

Removal – 1) Remove rocker arm cover. Remove rocker arms and spark plug from cylinder to be serviced. Install air line adapter to spark plug port and apply air pressure.

2) With rocker arm removed, install rocker arm nut loosely on stud. Using spring compressor (J-5892-1 or equivalent), compress valve spring and remove valve locks. Remove tool, retainer cupshield, spring and seal.

Installation – Reverse procedure used in removal to complete assembly.

NOTE – Valve spring installed height is 1.69". Test valves spring tension with tester while removed. Springs should be compressed to 1.66" without internal damper. Proper tension is 78-86 lbs. at this height.

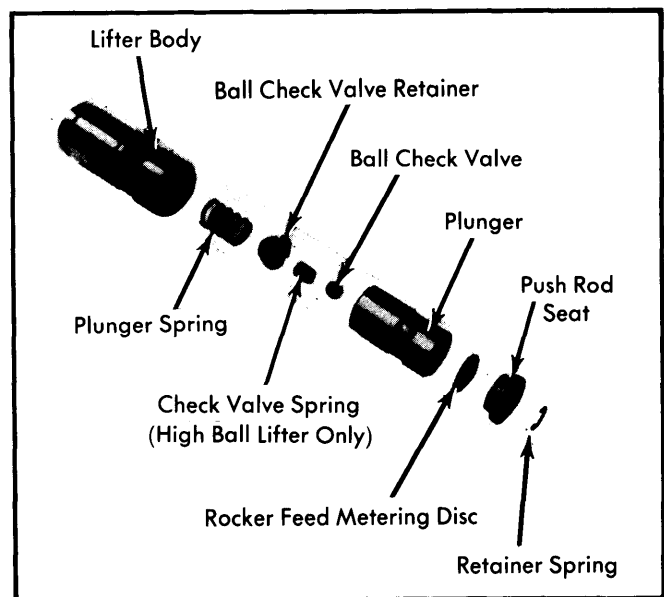

Fig. 5 Hydraulic Valve Lifter Assembly

HYDRAULIC VALVE LIFTERS

Valve lifters are serviced as complete units. Parts are not interchangeable between lifters. If lifter shows signs of wear or is noisy it should be replaced. Check cam mating surface for wear and if present, inspect camshaft. Replace parts as necessary. See Fig. 5.

PISTONS, PINS & RINGS

OIL PAN

See Oil Pan Removal at end of ENGINE Section.

PISTON & ROD ASSEMBLY

NOTE – New pistons must be installed in same cylinders for which they were fitted. Install used pistons in same cylinders from which they were removed.

151" 4 CYL. (Cont.)

Removal – 1) With cylinder head and oil pan removed, use a ridge reamer to remove any ridge or deposits from upper end of cylinder bore.

NOTE – Piston should be at bottom of stroke and covered with a cloth to collect cuttings.

2) Mark rod, rod cap and piston for cylinder identification if necessary. Remove bearing cap. Remove piston and rod assembly from top of cylinder block using care not to damage crankshaft journal or cylinder wall.

Installation – 1) Lightly coat cylinder bores, pistons and rings with engine oil. Ensure ring gaps are properly spaced and marked side of compression ring is facing upward.

2) Install ring compressor on piston, ensuring ring gap spacing does not change. Using suitable tool, gently tap piston and rod assembly into correct cylinder bore, taking care to avoid damaging cylinder wall or crankshaft.

NOTE – Notch in top of piston faces front of engine. Raised notch on side of rod at bearing end should be opposite notch in piston when installed. See Fig. 6.

3) Install bearing cap and tighten nuts. Reverse removal procedure to complete installation.



Fig. 6 Making Sure Connecting Rod and Piston Assembly Are Properly Indexed

FITTING PISTONS

Pistons are available in standard and oversizes up to .030". Selective fitting is required for each cylinder. Measure piston at right angles to pin axis just below lower ring groove. Mark pistons for correct cylinder once proper clearances have been established.

NOTE – Measure cylinder bore and pistons at room temperature for accurate reading.

PISTON PINS

Pins are press fit in piston. Oversize pins are available and piston and rod must be reamed for correct fit. Remove and replace piston pins using arbor press and suitable adapters.

CRANKSHAFT & ROD BEARINGS

MAIN & CONNECTING ROD BEARINGS

Connecting Rod Bearings – 1) Remove oil pan. Turn crankshaft and place rod to be serviced at bottom of stroke. Remove bearing cap and lower bearing shell.

2) Push piston and rod assembly up far enough to remove upper bearing shell.

3) Check clearances using Plastigage method and replace bearings as necessary. Bearings are available in standard, .001", .002" and .010" undersize.

4) Rotate crankshaft after installation of new bearings to ensure crankshaft is not binding. Reverse steps used in removal to complete assembly.

Main Bearings – 1) Replace main bearings in pairs. Do not shim or mix bearing sizes and do not use a new bearing with an old bearing.

2) Remove oil pan and remove bearing cap and bearing to be serviced. Using suitable tool, rotate upper bearing shell out by turning crankshaft in direction of locating notch in bearing saddle.

3) Check clearances using Plastigage method and replace bearings as necessary. Bearings are available in standard, .001", .002" and .010" undersize.

4) With new bearings lightly oiled and installed, rotate crankshaft to check for excessive drag. Reverse removal procedure to complete installation.

THRUST BEARING ALIGNMENT

Number 5 main bearing controls crankshaft end play. Move crankshaft fore and aft to measure end play. If not within specifications, thrust bearing must be replaced.

REAR MAIN BEARING OIL SEAL (VIN 1)

Removal – 1) Remove oil pan and rear main bearing cap. Pry oil seal from groove in bearing cap using care not to score or damage grooved area.

2) Using suitable tools, tap one end of upper seal until other end protrudes far enough to grasp with pliers. Carefully remove upper seal.

Installation – 1) Lightly coat new seal with engine oil and install in bearing cap. Ensure that seal is fully into groove.

2) Push new upper seal in place with lip toward engine front. Install bearing cap and tighten bolts. To complete installation, reverse removal procedure.

REAR MAIN BEARING OIL SEAL (VIN V & 9)

Removal – 1) Remove transmission, clutch housing and flywheel.

151" 4 CYL. (Cont.)

2) Remove rear main bearing seal with screwdriver using care not to scratch crankshaft.

Installation – 1) Coat new seal with engine oil and install by hand with lip toward engine. Ensure that seal is firmly in place.

2) Install flywheel clutch housing and transmission.

CAMSHAFT

ENGINE FRONT COVER

Removal – 1) Remove engine fan assembly and drive belts. Remove center hub bolt and slide hub and pulleys from crankshaft.

2) Remove two oil pan-to-cover screws and front cover-to-block screws. Using suitable tool, cut oil pan front seal flush with engine block. Remove front cover, gasket and attached portion of oil pan seal.

Installation – 1) Clean mating surfaces of block and engine front cover. Trim new oil pan front seal with proper tool, ensuring correct fit.

2) Install seal to front cover. Using suitable sealing compound, coat new cover gasket and install on cover. Apply silicone rubber sealer or equivalent to joint at oil pan and cylinder block.

3) Install front cover using centering tool (J-23042 or equivalent) and partially tighten two oil pan-to-cover screws.

4) Install and torque cover-to-block screws and oil pan-to-cover screws. Remove centering tool. Reverse removal steps to finish installation.

FRONT COVER OIL SEAL

Removal & Installation – 1) Remove engine front cover. Remove oil seal from front cover carefully.

2) Position new seal with lip toward rear of engine. Drive seal into cover using installer (J-23042 or equivalent).

3) Lightly coat seal contact area of balancer with engine oil. Push into position until balancer bottoms against crankshaft gear. Reverse removal process to complete installation.

CAMSHAFT & TIMING GEAR

Removal – 1) Drain cooling system and crankcase. Remove radiator and engine fan assemblies. Remove grille as required.

2) Remove rocker arm cover, loosen rocker arms and remove push rods. Remove fuel pump, distributor and spark plugs.

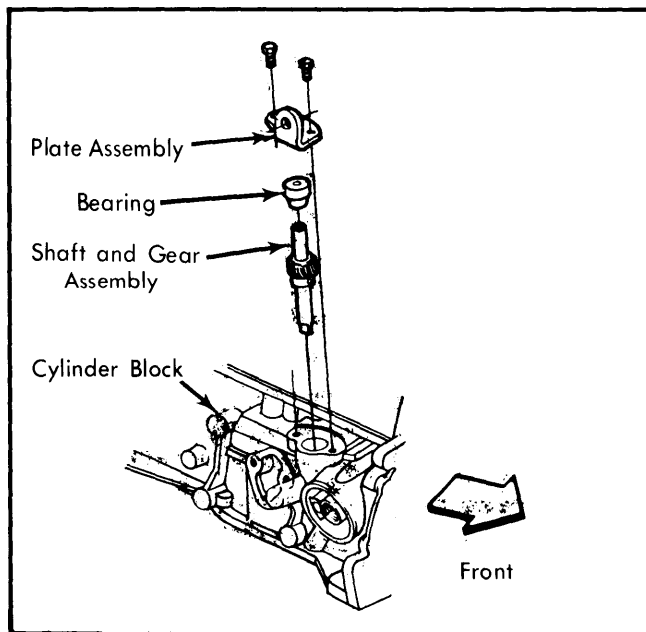

Fig. 7 Removing Oil Pump Drive Shaft

3) On crossflow head engines (VIN V and 9), remove oil pump drive shaft retaining bolts. Remove plate, bearing and shaft assembly. See Fig. 7.

4) Remove push rod cover and remove lifters. Take off engine front cover and remove two camshaft thrust plate screws. See Fig. 8.

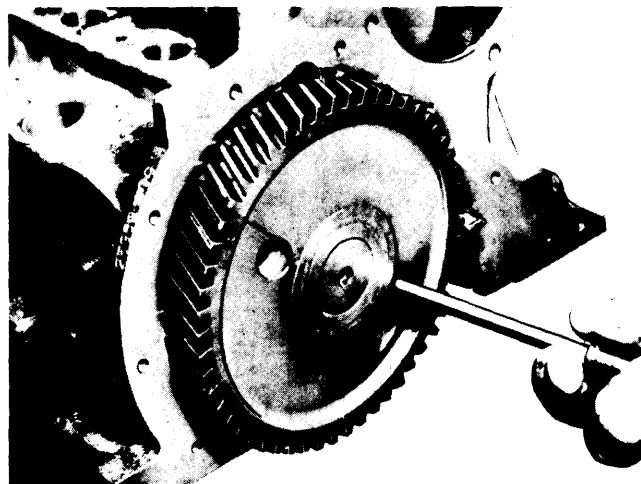

Fig. 8 Removing Thrust Plate Screw with Screwdriver Inserted Through Timing Gear

5) Carefully remove camshaft and gear assembly.

NOTE – Camshaft timing gear is pressed onto camshaft. When removing, ensure that Woodruff key does not damage camshaft.

151" 4 CYL. (Cont.)

Installation — 1) Install gear spacer ring, thrust plate and woodruff key onto camshaft. Using proper tools, press timing gear onto camshaft until gear bottoms against gear spacer ring. Measure thrust plate end clearance and replace spacer ring or thrust plate as required.

2) Carefully insert camshaft assembly into engine block. Rotate camshaft and crankshaft to align valve timing marks on gear teeth. See Fig. 9.

3) Install two camshaft thrust plate-to-block screws using two holes in camshaft gear for access. Tighten to 7 ft. lbs. Reverse removal procedures to complete assembly.

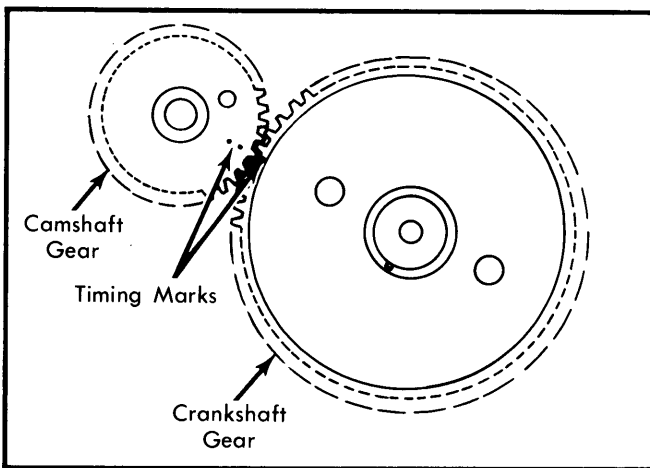

Fig. 9 Timing Gear Alignment

CAMSHAFT BEARINGS

Removal — 1) Remove oil pan and camshaft. Remove transmission, if engine is in vehicle, and remove flywheel. Drive expansion plug out rear of engine with suitable tool.

2) Drive out front bearing toward rear and rear bearing toward front with approved tool (J-21473-1 or equivalent). Using extension (J-21054-1), drive out center bearing toward rear.

Installation — 1) Install bearings using reverse procedure, ensuring that oil holes line up in camshaft bearings and engine block.

2) Install front camshaft bearing so that bearing is recessed about $\frac{1}{8}$ " into engine block. This will allow for lubrication of timing gears. Reassemble engine by reversing steps used in disassembly.

ENGINE OILING

ENGINE OILING

Crankcase Capacity — 3 quarts. Add one quart with filter change.

Oil Filter — Full flow type. Change filter at first oil change and every second oil change thereafter.

Normal Oil Pressure — 36-41 psi at 2000 RPM.

Pressure Regulator Valve — Located in oil pump body. Not adjustable.

ENGINE OILING SYSTEM

Gear type oil pump directs oil under pressure through full flow oil filter and into an oil gallery on right side of block. Oil from this gallery lubricates lifters. Oil is then routed to camshaft and crankshaft bearings through drilled passages. Rocker arms receive lubrication through holes in hydraulic lifters which feed oil through tubular push rods. Bypass valves are located in the pickup screen, filter mounting and oil pump to allow for any clogged or restricted components. Timing gears are lubricated through oil hole forward of No. 1 camshaft bearing which feeds into a nozzle above gears. Other engine components are fed by gravity or oil throw-off from directly oiled parts. Oil returns to pan through drains in head and block. See Fig. 10.

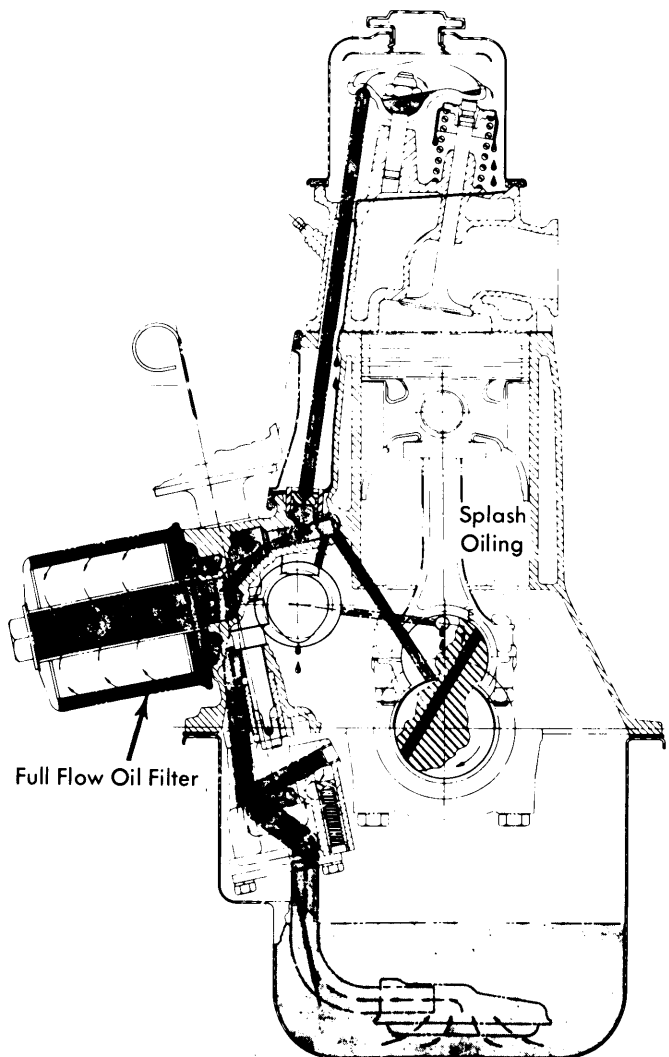

Fig 10 Engine Oiling System
(VIN 1 Shown)

151" 4 CYL. (Cont.)

OIL PUMP

Oil pump is located beneath engine and oil pan must be removed for access. See *Oil Pan Removal at end of ENGINE Section*. Remove oil pump and screen as an assembly. Do not disturb oil pickup pipe on pump body or screen. Disassemble pump and inspect for excessive wear or cracks. Replace oil pump as a unit if any parts are defective. See Fig. 11.

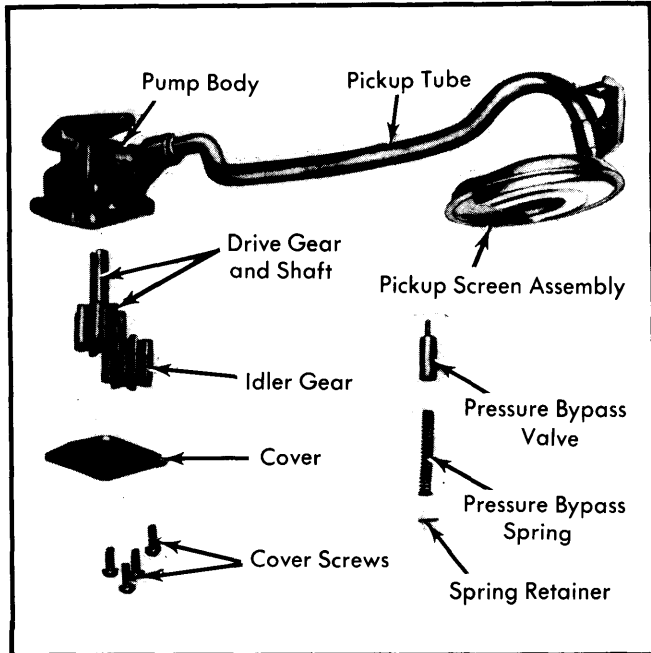

Fig. 11 Exploded View of Engine Oil Pump Assembly

TIGHTENING SPECIFICATIONS (VIN 1)

Application	Ft. Lbs.
Cylinder Head	95
Flywheel-to-Crankshaft	55
Cam Thrust Plate-to-Block	5
Connecting Rod	30
Harmonic Balancer	160
Engine Front Cover	6
Intake-to-Exhaust Manifold	40
Manifold-to-Head Nut	30
Manifold-to-Head Bolt	40
Main Bearing Cap	65
Oil Pan Screw (front)	3
Oil Pan Screw (side)	6
Oil Pump-to-Block	9
Water Pump	18
Water Outlet	20

TIGHTENING SPECIFICATIONS (VIN V & 9)

Application	Ft. Lbs.
Cylinder Head	85
Flywheel-to-Crankshaft	50
Cam Thrust Plate-to-Block	7
Connecting Rod	32
Harmonic Balancer	160
Engine Front Cover	7
Intake Manifold-to-Head	30
Exhaust Manifold-to-Head	45
Main Bearing Cap	70
Oil Pan Screw	6
Oil Pump-to-Block	22
Water Pump	25
Water Outlet	20

ENGINE SPECIFICATIONS

GENERAL SPECIFICATIONS						
Engine	Net HP At RPM	Torque (Ft. Lbs. at RPM)	Compr. Ratio	Bore	Stroke	Displ. Cu. Ins.
151" VIN 1	85@4400	123@2800	8.3-1	4.00"	3.00"	151
151" VIN V	90@4400	128@2400	8.2-1	4.00"	3.00"	151
151" VIN 9	①	①	8.2-1	4.00"	3.00"	151

① - Not available from manufacturer at time of publication.

VALVES

Engine & Valve	Head Diam.	Face Angle	Seat Angle	Seat Width	Stem Diameter	Stem Clearance	Valve Lift
151"							
Int.	1.72"	45°	46°3418-.3425"	.0010-.0027"	.406"
Exh.	1.50"	45°	46°3418-.3425"	.0010-.0027"①	.406"

① - Measure at top of guide. Bottom is .0020-.003,

General Motors 4 Engines

151" 4 CYL.

ENGINE SPECIFICATIONS (Cont.)

PISTONS, PINS, RINGS						
Engine	PISTONS	PINS		RINGS		
	Clearance	Piston Fit	Rod Fit	Rings	End Gap	Side Clearance
151" (VIN 1)	.0025-.0033"	.0002-.0004"	Press Fit	1&2	.010-.020"	.0015-.0035"
151" (VIN V & 9)	.0025-.0033"	.0002-.0004"	Press Fit	3	.010-.020"	.0015-.0035"
				1	.015-.025"	.0030"
				2	.009-.019"	.0030"
				3	.015-.055"	.0030"

CRANKSHAFT MAIN & CONNECTING ROD BEARINGS							
Engine	MAIN BEARINGS				CONNECTING ROD BEARINGS		
	Journal Diam.	Clearance	Thrust Bearing	Crankshaft End Play	Journal Diam.	Clearance	Side Play
151" (VIN 1)	2.2983-2.2993"	.0002-.0022"	No. 5	.0015-.0085"	2.000"	.0005-.0026"	.006-.022"
151" (VIN V & 9)	2.3000"	.0005-.0022"	No. 5	.0035-.0085"	2.000"	.0005-.0026"	.006-.022"

VALVE TIMING				
Engine	INTAKE		EXHAUST	
	Open (BTDC)	Close (ALDC)	Open (BLDC)	Close (ATDC)
151"	33°	81°	76°	38°

CAMSHAFT			
Engine	Journal Diam.	Clearance	Lobe Lift
151"	1.869"	.0007-.0027"	.406"