

CHEVROLET PROPELLER SHAFT ALIGNMENT

Chevrolet (Exc. Camaro, Chevette, Monza & Nova)

DESCRIPTION

To properly measure front and rear universal joint angles, vehicle must be at proper trim height (distance from top of axle tube to bottom of frame). If necessary, add weight to meet this distance. With vehicle level and supported at axles, an inclinometer is used to determine driveline angles. Adjustment may be accomplished by shims at the transmission mounting or by changing control arms.

CHECKING & ADJUSTING

CHECKING

Clean all bearing cups and place suitable inclinometer (J-23498) on rear propeller shaft bearing cup. See Fig. 1. Center sight glass bubble and record reading. Rotate propeller shaft 90° and place inclinometer on companion flange bearing cup. Measure angle and subtract smaller from larger angle to determine transmission angle.

NOTE — To ensure accuracy, check and record angles at all four bearing caps on each end of shaft.

ADJUSTMENT

Transmission Shimming — One shim added to transmission rear bearing retainer at transmission mount will change front angle $-\frac{1}{2}^{\circ}$ and rear angle $+\frac{1}{4}^{\circ}$.

NOTE — Production bolt is M 10 1.5 X 35 mm. When using two or more shims, a M 10 1.5 X 50 mm bolt must be used.



Fig. 1 Measuring Angle at Rear Propeller Shaft Bearing Cup

Upper Control Arm Change — Shorter or longer arms may be used to change drive line angles $\pm\frac{1}{2}^{\circ}$ at transmission and $\pm 2^{\circ}$ at differential. See Table.

Universal Joint Angle Change with Rear Upper Control Arm

Application and Arm Type	Rear Angle Change	Front Angle Change
Impala, Caprice		
Short Arm	+2°	$-\frac{1}{2}^{\circ}$
Long Arm	-2°	$+\frac{1}{2}^{\circ}$
El Camino, Malibu, Monte Carlo		
Short Arm	$+\frac{1}{2}^{\circ}$	$-\frac{1}{2}^{\circ}$
Long Arm	$-\frac{1}{2}^{\circ}$	$+\frac{1}{2}^{\circ}$

Correct Universal Joint Angle ($\pm\frac{1}{2}^{\circ}$)

Application & Height ($\pm\frac{1}{4}$ ")	Front Joint	Rear Joint
Impala, Caprice		
7 $\frac{1}{2}$ " Axle - 5.98"	2°	2 $\frac{1}{4}$ °
8 $\frac{1}{2}$ " Axle - 5.98"	1 $\frac{3}{4}$ °	2 $\frac{1}{4}$ °
8 $\frac{3}{4}$ " Axle Wagon		
4.39"	2 $\frac{1}{4}$ °	3°
El Camino, Malibu, Monte Carlo		
7 $\frac{1}{2}$ " Axle - 4.21"	$\frac{3}{4}$ °	1 $\frac{1}{4}$ °
7 $\frac{1}{2}$ " Axle Wagon		
4.2"	$\frac{1}{4}$ °	1 $\frac{1}{2}$ °

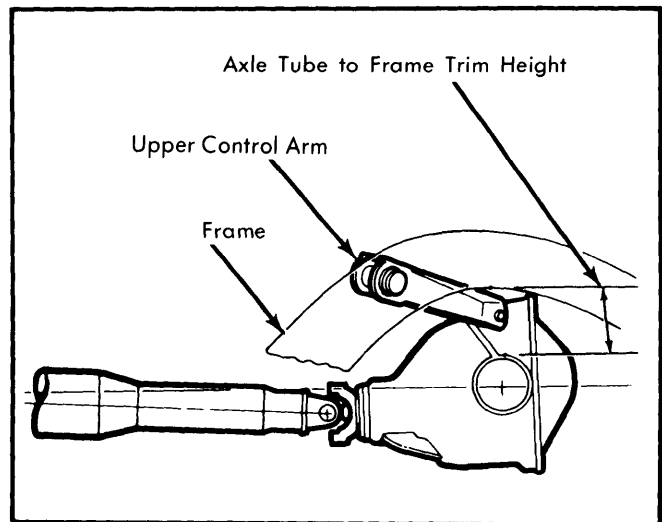

Fig. 2 Trim Height Check