

AMERICAN MOTORS

American Motors (All Models)

DESCRIPTION

Rear axle assembly consists of a cast iron housing and two steel axle tubes which are pressed into this center section. A conventional or optional Twin-Grip limited slip differential drives the semi-floating tapered axle shafts. Hypoid ring gears of 7 7/16" diameter are used with AMX, Concord, Gremlin and Pacer models. All Matador and V8 equipped AMX and Concord models use the 8 7/8" size.

NOTE — For models with limited slip differential, see American Motors Twin-Grip Differential in this section.

Axle Ratio Identification

Code	Axle Ratio	Ring Gear Diameter
A	3.54-1 (11/39)	8-7/8"
B	3.15-1 (13/41)	8-7/8"
C	2.87-1 (15/43)	8-7/8"
D	3.91-1 (11/43)	8-7/8"
X	2.56-1 (16/41)	8-7/8"
E	3.58-1 (12/43)	7-9/16"
F	3.08-1 (13/40)	7-9/16"
G	3.31-1 (13/43)	7-9/16"
H	2.73-1 (15/41)	7-9/16"
K	2.53-1 (17/43)	7-9/16"

REMOVAL & INSTALLATION

HUBS & DRUMS

Removal — Remove axle shaft nut, then raise and support vehicle. Remove drum retaining screw, then remove drum from hub. Attach a puller (J-1644-02) and remove hub from axle shaft. **NOTE** — Use of a slide hammer type of puller on axle shaft may cause damage to rear wheel bearings or thrust block.

CAUTION — Procedures for reinstalling original hub and installing a new hub and drum assembly differ.

Installation (Original Hub) — Align keyway in hub with axle shaft key, slide hub onto axle shaft, then install axle shaft washer and nut. Install drum, retaining screws and wheel. Lower vehicle onto wheels, then tighten axle shaft nut. If cotter pin hole is not aligned, tighten nut to next castellation, then install cotter pin.

NOTE — When a new axle shaft is installed, a new hub must also be installed. A new hub may be installed onto the original axle shaft if serrations (splines) on axle shaft are not worn or damaged.

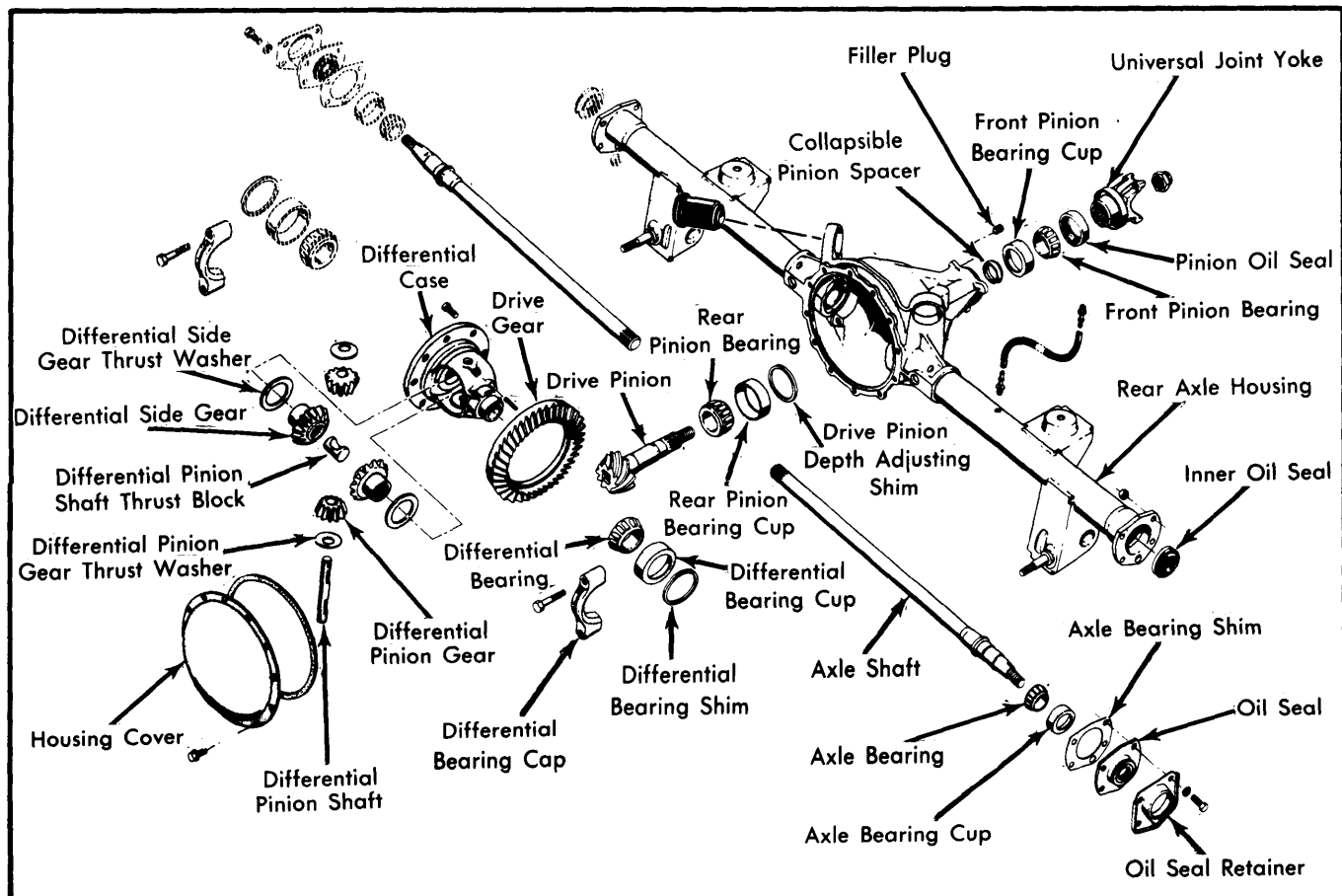

Fig.1 Exploded View of American Motors Rear Axle Assembly (AMC 8-7/8" Axle Shown)

AMERICAN MOTORS (Cont.)

Installation (New Hub) – 1) Align keyway in hub with axle shaft key, then slide hub onto axle shaft as far as possible. Install two lubricated thrust washers and axle shaft nut. Install drum, wheel, and lower vehicle.

2) Tighten axle shaft nut until distance from hub outer face to axle shaft outer end is $1\frac{3}{16}$ " on the $7\frac{9}{16}$ " axle and $1\frac{5}{16}$ " on the $8\frac{7}{8}$ " axle (refer to Fig. 2). Remove axle shaft nut and one thrust washer, then reinstall nut and tighten. If cotter pin hole is not aligned, tighten nut to align hole (do not loosen). Install cotter pin.

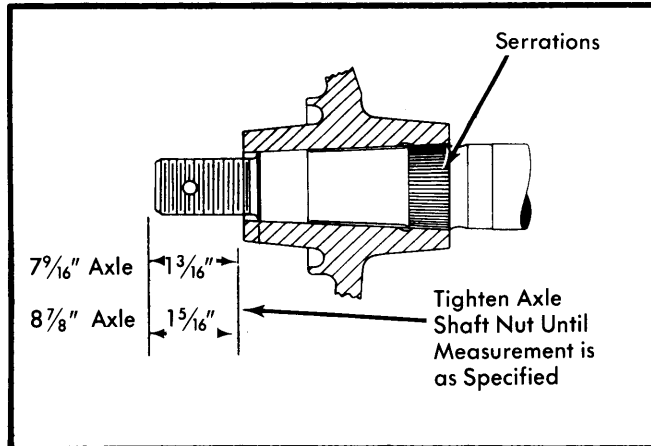

Fig. 2 Hub Installation Measurements

AXLE SHAFTS & BEARINGS

Removal – 1) Remove rear wheel, drum and hub. Disconnect parking brake cable at equalizer and brake tube at wheel cylinder.

2) Remove brake support plate assembly, oil seal, and axle shims from axle shaft. **NOTE** – End play shims are located on left axle shaft only.

3) Using suitable puller, remove axle shaft from axle tube. Remove and discard oil seal. Remove bearing from axle shaft using arbor press.

Installation – 1) Pack bearing with wheel bearing grease. Press bearing onto axle shaft with small diameter of cone toward threaded end of shaft. Coat inner axle shaft seal with light oil. Coat outer surface of seal metal retainer with a sealant.

2) Install oil seal, axle shaft, and outer bearing cup. Install original shims, oil seal assembly, and brake support plate. Install and tighten bolts. **NOTE** – Oil seal and retainer are installed between axle flange and support plate on $7\frac{9}{16}$ " axle, and on outside of brake support on $8\frac{7}{8}$ " axle.

End Play Adjustment – 1) Strike each axle shaft with a lead hammer (or soft mallet) to seat bearing cups against support plate. Attach a suitable end play checking tool (J-2092) to end of shaft. Install dial indicator to support plate or tool.

2) Check end play by pushing and pulling on shaft. End play should be .004-.008", with .006" desired. Add shims to left side only to increase end play. Remove shims from left side only to decrease end play.

REAR YOKE & PINION OIL SEAL

Removal – 1) Raise and support vehicle, then remove wheels. Remove propeller shaft, marking parts for reassembly reference. Use an INCH lb. torque wrench to rotate pinion several revolutions. Record torque required to turn drive pinion.

2) Using suitable tools, remove and discard pinion nut. Mark drive pinion shaft and yoke for reassembly reference, then remove yoke using pullers. Using suitable tool (J-9233 or J-7583), remove pinion oil seal.

Installation – 1) Coat new seal with rear axle lubricant, then install seal (use tool J-22661 if available). Install rear yoke aligning marks made at disassembly. Install NEW pinion nut and tighten just enough to remove end play. **CAUTION** – Do not overtighten.

2) Using an INCH pound torque wrench, check torque required to turn drive pinion. If preload torque is less than desired (5 INCH lbs. over disassembly reading), tighten pinion nut slightly and recheck preload.

3) Repeat procedure until desired preload is obtained. **CAUTION** – Do not loosen then retighten, or overtighten pinion nut. If desired preload is exceeded, a new collapsible pinion spacer sleeve must be installed and drive pinion preload reset.

REAR AXLE ASSEMBLY

Pacer, Gremlin & Hornet – 1) Remove axle shaft nuts prior to raising vehicle, raise and support vehicle. Remove axle housing cover, rear wheels, hubs and drums.

2) Disconnect rear parking brake cables at equalizer, then remove brake support plates. **NOTE** – Retain shims located between left support plate and axle tube.

3) Remove axle shafts and disconnect propeller shaft. Remove rear shock absorbers at axle and brake line at body floor pan bracket.

4) Remove rear spring "U" bolts, then remove axle assembly from vehicle. To install, reverse removal procedure. Bleed hydraulic system and adjust parking brake cables.

Matador – 1) Remove axle shaft nuts then raise vehicle. Remove housing cover to drain lubricant. Disconnect brake lines at support plates, then remove wheels, hubs, and drums. Mark propeller shaft and pinion flange for reassembly reference, then disconnect and support propeller shaft.

2) Disconnect parking brake cables. Remove brake support plates, seals, axle shafts and bearings. Disconnect vent hose at axle tube. Support axle assembly. If equipped with air adjustable shock absorbers, release all air pressure then disconnect shock absorbers at lower control arms.

3) Lower axle assembly and disconnect upper control arms at axle housing. Pull axle tube downward to remove springs. Disconnect lower control arms at axle tube brackets. Lower axle assembly and remove from vehicle.

4) To install, reverse removal procedure. Bleed hydraulic system and adjust parking brake cable. Fill rear axle with suitable lubricant.

AMERICAN MOTORS (Cont.)

OVERHAUL

DISASSEMBLY

NOTE — It is not necessary to remove axle assembly to perform overhaul. However, underbody should be cleaned to prevent dirt contamination.

1) Remove rear cover and drain lubricant. Remove drums, hubs, axle shafts, oil seals and end play shims. Mark bearing caps for reassembly reference, then remove caps and pry differential case from housing.

2) Tie bearing shims to their respective caps to prevent misplacement. Remove ring gear from case, then remove pinion shaft lock pin. Measure and record differential side gear-to-case clearance for assembly reference.

3) Insert equal thickness feeler gauges between each gear and case to measure clearance. **NOTE** — Do not remove either feeler gauge until clearance at both gears has been measured to ensure accurate measurement. Remove pinion shaft, thrust block, pinion gears, side gears and thrust washers from case.

4) Remove pinion nut, then remove rear yoke and seal. Using a soft faced hammer, tap end of pinion shaft to free front bearing cone from shaft, then remove bearing.

5) Remove drive pinion and rear bearing from housing. Discard collapsible spacer. Drive out front and rear bearing cups. Keep pinion depth shims (located behind rear bearing cup) for reassembly.

INSPECTION

Inspect all parts for wear or damage. Pinion shaft should be a press fit to a .010" loose fit in case. Clearance of differential gear in case bore should not exceed .007". Clean all parts thoroughly, replace as necessary.

REASSEMBLY

Drive Pinion — 1) Press rear bearing on pinion stem with large diameter of roller cage toward gear. Clean housing bearing bores.

2) Place shim in rear bearing bore and install rear bearing cup. **NOTE** — When a new gear set is being installed, use original depth shim as a starting point. Chamfered side of shim must be installed to bottom side of rear bearing cup bore.

3) Center shim to prevent tipping bearing cup. Install front bearing cup into housing. Install drive pinion through rear bearing cup. Install front bearing, rear yoke, and original pinion.

4) Tighten nut to remove bearing end play only. **NOTE** — A new nut and collapsible spacer are not installed at this time as pinion will be removed after a depth measurement.

Drive Pinion Bearing Preload — 1) Install collapsible spacer and front bearing on drive pinion. Install oil seal rear yoke and nut. Using suitable tools, tighten pinion nut only enough to remove bearing end play.

2) Gradually tighten nut to collapse spacer and preload bearings. **CAUTION** — Do not overtighten. Using an INCH lb. torque wrench, measure torque required to turn drive pinion. If preload torque is less than desired, tighten pinion nut slightly and recheck preload.

3) Continue procedure until desired preload is obtained. **CAUTION** — Do not exceed preload torque. Do not back off nut to lessen preload. If preload torque is exceeded, replace collapsible spacer and adjust preload to correct torque.

Drive Pinion Depth — 1) Observe numbers painted on drive pinion and ring gear. First number on pinion must match number on ring gear.

NOTE — If numbers do not match, gear set is not a matched set and should not be used. Some factory installed sets may have .010" or .020" machined off the pinion end face. Identifying numbers will appear as +23, number 2 indicating that .020" was removed from the end face and .003" is pinion depth variance. If marked +16, the number 1 indicates that .010" was removed from end face and the number indicates variance in pinion depth is .006". These gear sets are exclusively factory installed.

2) Second number on pinion is pinion depth variance. If number is preceded by a plus sign, add that number to standard pinion depth. If number is preceded by a minus sign, subtract that from standard pinion depth.

3) Standard pinion depth on 7¹/₁₆" axle is 2.095". Standard pinion depth on 8⁷/₈" axle is 2.547". Result of addition or subtraction will be desired pinion depth. Record this measurement for future reference.

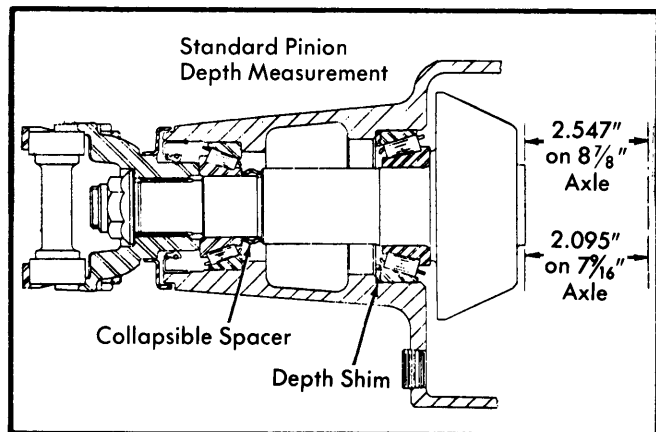

Fig. 3 Pinion Depth and Preload Shim Location

4) Mount gauge arbor tool (J-5223-4) and discs (J-5223-23 on 8⁷/₈" axle; J-6381-2 on 7¹/₁₆" axle). Install gauge assembly with discs fully seated in housing bores. Install bearing caps and tighten bolts.

5) Position gauge block (J-5223-20) against end of drive pinion with clamp bar and screw (J-5223-24). Loosen thumbscrew in end of gauge block and allow spring loaded plunger to contact arbor. Tighten thumbscrew, taking care not to disturb position of plunger.

6) Remove gauge block and measure distance from end of anvil to top of plunger head using a two to three inch

Drive Axles

AMERICAN MOTORS (Cont.)

micrometer. Record this measured pinion depth for future reference.

7) Remove gauging tools, drive pinion and rear bearing cup. Remove drive pinion depth shim and record thickness. Add shim thickness to measured pinion depth. From this total subtract desired pinion depth.

8) The result represents correct shim thickness to be installed.
NOTE — Replacement gears marked with more than $\pm .009$ " variance should not be used. Install correct thickness shim in rear bearing bore and install rear bearing cup.

9) The Pinion Variance Chart will help determine the appropriate starter shim thickness when installing NEW gear sets. Note pinion variance numbers on new and old gear, and then follow old pinion marking line across to new pinion marking column. The number in the box indicates the change in shim thickness from original. For example, old pinion marked -3 and new pinion marked +2. Intersecting box shows -.005" to be subtracted from original shim thickness.

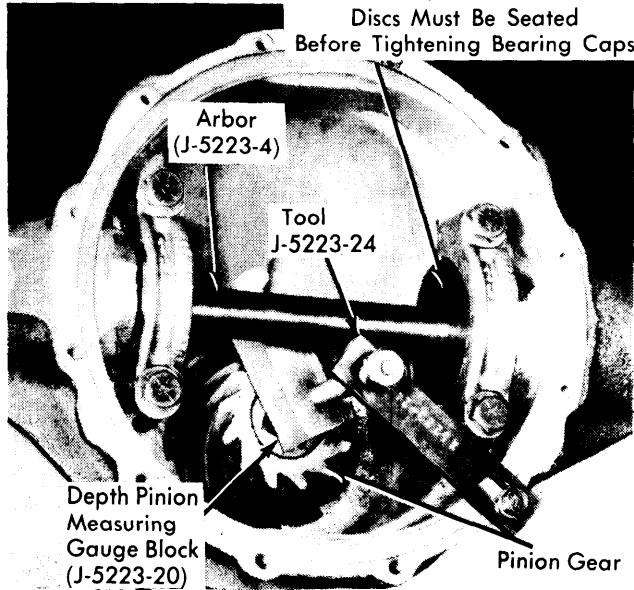

Fig. 4 Drive Pinion Depth Measurement

NOTE — The starter shim thickness must not be used as a final shim setting. An actual pinion depth measurement must be made and final shim thickness adjusted as necessary.

Assembling Differential Carrier — 1) Using suitable installation tools, install differential bearings onto case. Install thrust washers on differential gears (oil pocket side toward gear). Install gears into bores in differential case.

2) Install thrust washers behind differential pinion gears. Mesh gears with differential gears so holes in gears are opposite and in line with each other. Roll gears around until differential pinion gear holes are aligned with shaft holes in case.

3) Install thrust block through a differential gear, aligning hole in block with pinion shaft holes. Install pinion shaft aligning lock pin hole in shaft with lock pin hole in case.

4) Measure any existing clearance between differential gears and case, using two feeler gauges on opposite sides of one gear. Clearance should not exceed .007".

5) If the previously measured side gear-to-case clearance was more than .007" and thrust surfaces of the case are not worn, replace thrust washers and recheck clearance. If clearance is still more than .007" replace side gears as a set. Drive lock pin into place.

Adjusting Differential Bearings — 1) Place bearing cup over each differential bearing. Install differential case assembly in axle housing. Install a shim on each side between bearing cup and housing. Use .080" shims on the 8 $\frac{7}{8}$ " axle, or .142" shims on 7 $\frac{5}{16}$ " axles.

2) Install bearing caps and tighten bolts finger tight. Mount dial indicator to housing so that button of indicator touches drive gear face of differential case. Using two screwdrivers, pry between shims and housing. Pry assembly to one side, zero indicator, then pry assembly to opposite side and read indicator. **NOTE** — Do not zero or read indicator while prying.

3) Amount read on indicator is amount of shim to be added to arrive at a no preload and no end play condition. Shims are

PINION VARIANCE CHART

Old Pinion Marking	New Pinion Marking								
	-4	-3	-2	-1	0	+1	+2	+3	+4
+4	+0.008	+0.007	+0.006	+0.005	+0.004	+0.003	+0.002	+0.001	0
+3	+0.007	+0.006	+0.005	+0.004	+0.003	+0.002	+0.001	0	-0.001
+2	+0.006	+0.005	+0.004	+0.003	+0.002	+0.001	0	-0.001	-0.002
+1	+0.005	+0.004	+0.003	+0.002	+0.001	0	-0.001	-0.002	-0.003
0	+0.004	+0.003	+0.002	+0.001	0	-0.001	-0.002	-0.003	-0.004
-1	+0.003	+0.002	+0.001	0	-0.001	-0.002	-0.003	-0.004	-0.005
-2	+0.002	+0.001	0	-0.001	-0.002	-0.003	-0.004	-0.005	-0.006
-3	+0.001	0	-0.001	-0.002	-0.003	-0.004	-0.005	-0.006	-0.007
-4	0	-0.001	-0.002	-0.003	-0.004	-0.005	-0.006	-0.007	-0.008

AMERICAN MOTORS (Cont.)

available from .080-.110" in .002" variations for the 8⁷/₈" axles, and from .142-.174" in .002" variations for the 7¹/₁₆" axles.

4) When all side play is eliminated, check drive gear face of case for runout. Runout should not exceed .002". Remove case from housing, retain shims used to eliminate side play.

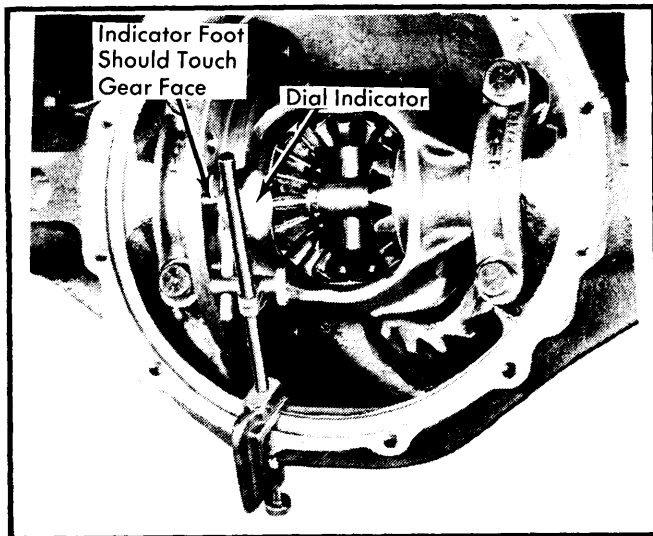

Fig. 5 Differential Bearing Side Play and Runout Measurement

Ring Gear Installation – Place gear on case and install attaching bolts. Tighten bolts alternately and evenly.

Backlash Adjustment – 1) Install differential assembly in housing using shims selected to remove side play. Tighten bearing cap screws evenly.

2) Attach a dial indicator to housing so that button of indicator contacts drive side of a tooth of drive gear, and at a right angle to it. Rock drive gear and note movement on dial indicator.

3) Backlash should be .005-.009", with .008" desired. To increase backlash, install a thinner shim on drive gear side and a thicker shim on opposite side. To increase backlash, reverse procedure but do NOT change total thickness of shims.

Differential Bearing Preload – 1) Differential bearings are preloaded by increasing each shim thickness by .004". Install differential bearing shims in axle housing bearing bores.

2) Assemble bearing cups on bearings (cups should completely cover rollers). Position differential so that bearings just start in axle housing bearing bores. Keep assembly square in housing and push in as far as possible.

3) Using a soft hammer, tap outer edge of bearing cups until seated in housing. **CAUTION** – Do not distort shims by hammering them into housing.

4) Install bearing caps, aligning marks made at disassembly. Install and tighten bolts. Preloading differential bearings may change backlash setting, therefore recheck backlash and correct if necessary.

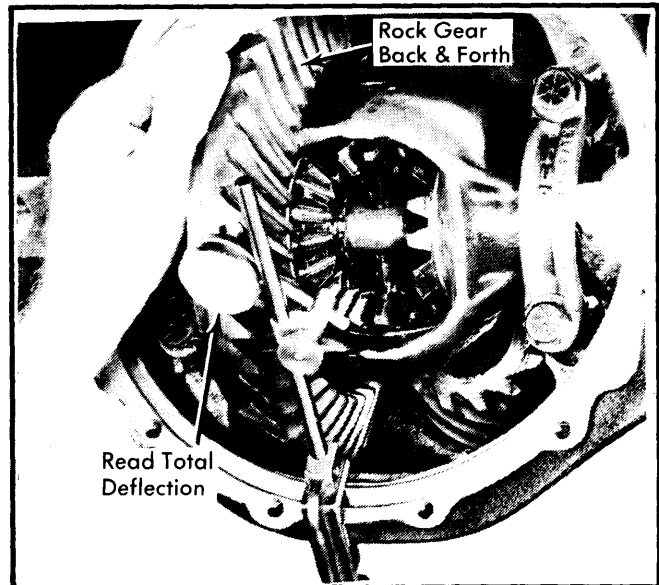

Fig. 6 Differential Gear Backlash Check

5) After all adjustments have been made, make a gear tooth pattern check to make sure of a correct assembly. Install propeller shaft, axle shafts, bearings seals, brake support plates, hubs and drums. Reverse disassembly procedure to complete reassembly. Fill rear axle with lubricant.

AXLE ASSEMBLY SPECIFICATIONS

Application	Specification
Pinion Bearing Preload	
7 ¹ / ₁₆ "	15-25 INCH Lbs.
8 ⁷ / ₈ "	17-28 INCH Lbs.
Differential Bearing Preload	.008"
Drive Gear-to-Pinion Backlash	.005-.009"
Case Flange Runout	.002" Max.
Gear-to-Case Clearance	.007" Max.
Axle Shaft End Play	.004-.008"

TIGHTENING SPECIFICATIONS

Application	Ft. Lbs.
Housing Cover	14
Brake Support Plate	32
Rear Hub-to-Axle Shaft Nut	Min. 250
Differential Bearing Cap	
7 ¹ / ₁₆ " Axle	57
8 ⁷ / ₈ " Axle	87
Drive Gear-to-Case	
7 ¹ / ₁₆ " Axle	52
8 ⁷ / ₈ " Axle	105
Universal Joint Bolts	14