

AMERICAN MOTORS & CHRYSLER CORP.

American Motors Chrysler Corp.

NOTE — Clutch manufacturer does not recommend overhaul of these clutches.

DESCRIPTION

Clutches are single plate dry disc design. Two types of clutch release mechanisms are used. Chrysler Corp. uses a three finger release system. Centrifugal rollers are used on some Chrysler Corp. models for increased clutch pressure at high speed.

American Motors uses a diaphragm release system. Three clutch cover designs are used. One is a six bolt clutch cover and is used on all six cylinder models with three speed transmissions. The second is a three bolt clutch cover and is used on all six cylinder models with a four speed transmission. The third is a six bolt clutch cover and is used on Gremlin models with the four cylinder engine and four speed transmissions.

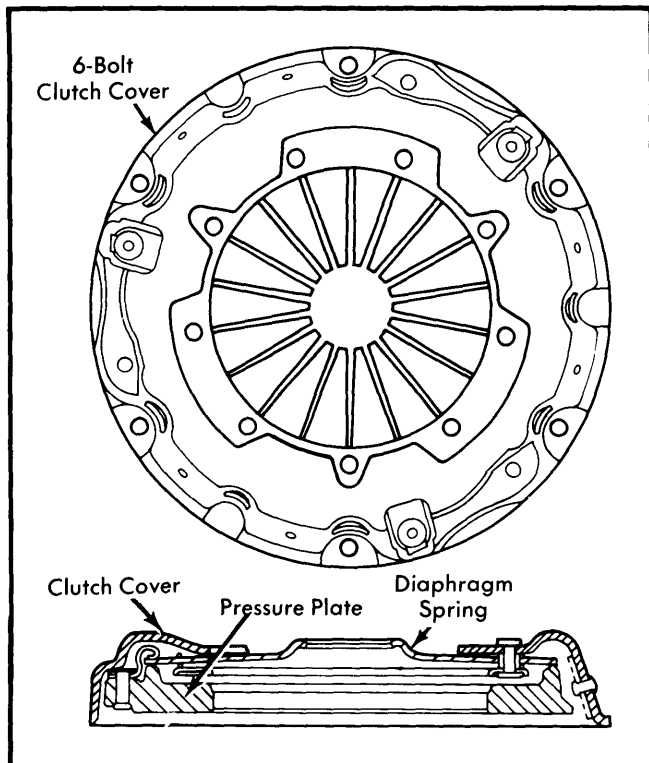

Fig. 1 American Motors 6-Bolt Clutch (All 6-Cyl. with 3-Speed Transmissions)

REMOVAL & INSTALLATION

CLUTCH

American Motors — 1) On six cylinder models remove starter, transmission, throw-out bearing, release lever, and clutch housing. Mark flywheel and clutch cover for reassembly reference. When removing clutch cover, loosen attaching bolts evenly and in rotation to avoid warping. To install, reverse removal procedure.

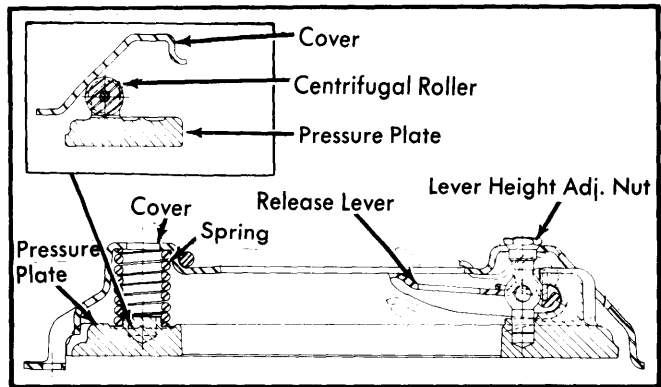

Fig. 2 Cross Sectional View of Chrysler Corp. Clutch

2) On four cylinder models remove starter, propeller shaft and transmission crossmember. Remove inspection plate from front of clutch housing cover. Remove transmission and clutch housing as an assembly. Mark clutch cover and flywheel for reassembly reference. Remove clutch and clutch disc. **NOTE** — Loosen clutch cover bolts alternately and evenly to avoid warping clutch cover. To install, reverse removal procedure aligning clutch cover with scribe marks and dowl pins in flywheel.

Chrysler Corp. — Remove transmission, clutch housing pan, release bearing, and linkage. Mark flywheel and clutch cover for reinstallation. Loosen clutch cover attaching bolts evenly and in rotation to prevent warping cover. For installation, reverse removal procedure.

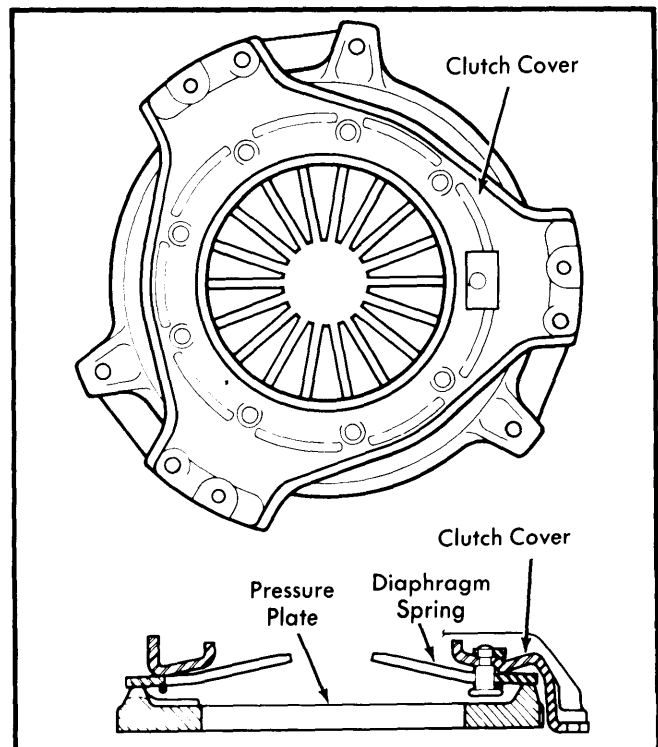

Fig. 3 American Motors 3-Bolt Clutch (All 6-Cyl. with 4-Speed Transmissions)

AMERICAN MOTORS & CHRYSLER CORP. (Cont.)

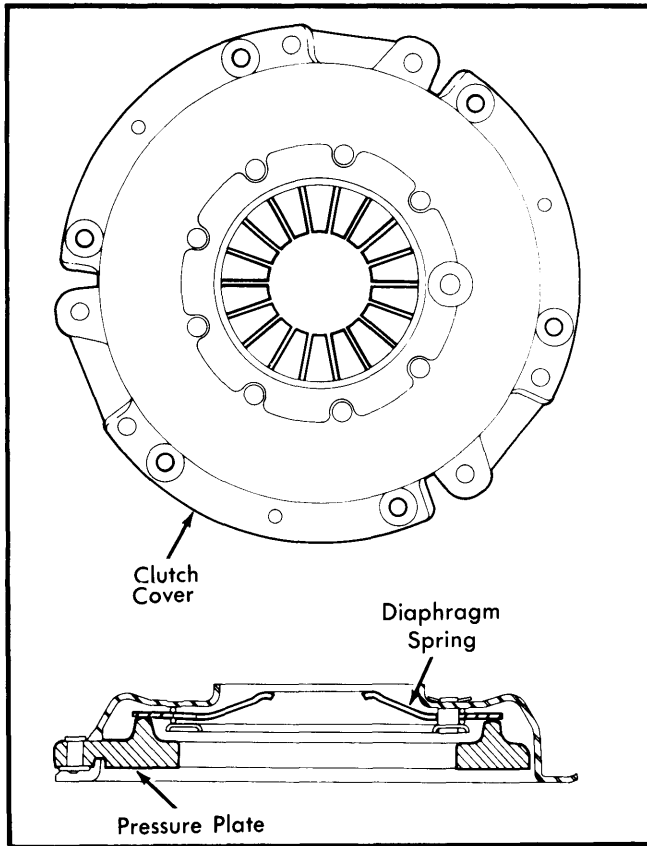

Fig. 4 American Motors 6-Bolt Clutch
(All 4-Cyl. with 4-Speed Transmissions)

PILOT BUSHING

American Motors – 1) On six cylinder models fill crankshaft cavity and pilot bushing bore with an all purpose lubricant. Insert clutch aligning tool straight into bushing. Tap with a brass hammer. Hydraulic pressure will force bushing out of crankshaft. For installation, use suitable driver and install bushing straight into crankshaft until it seats. Lubricate bushing and install lubrication wick.

2) On four cylinder models insert a pilot bearing puller (J-26833) into pilot bearing and remove bearing. To install, lubricate pilot bearing in a suitable chassis grease and install on a installer tool (J-26904). Position tool with bearing in crankshaft. Tap tool with a hammer to seat bearing in crankshaft.

Chrysler Corp. – Using suitable puller (SP-3631) remove bushing. Before installing new bushing, soak it in oil. For installation, use suitable driver; then place small amount of grease in crankshaft cavity, forward of bushing.

ADJUSTMENT

PEDAL ADJUSTMENT

American Motors – 1) Adjust pedal free play by changing the length of throw-out lever-to-bellcrank rod on six cylinder models or clutch cable length on four cylinder models.

2) On six cylinder models lengthen rod to reduce free play. On four cylinder models loosen lock nut at transmission end of cable. Pull cable toward front of vehicle until free movement of clutch lever is eliminated. Tighten adjusting nut until tabs of adjusting nut hit clutch housing cover.

3) Release cable and tighten adjusting nut until tabs align with slots of housing cover. Tighten lock nut and check pedal free play. Free play should be $\frac{7}{8}$ - $1\frac{1}{8}$ " with $1\frac{1}{8}$ " preferred on six cylinder models or $\frac{7}{8}$ - $1\frac{1}{4}$ " with $1\frac{1}{8}$ " preferred on four cylinder models.

Chrysler Corp. – Adjust self-locking nut on clutch fork rod to provide $\frac{5}{32}$ " free movement at fork-to-push rod pin. This will provide correct 1" free play at pedal.

TIGHTENING SPECIFICATIONS

Application	Ft. Lbs.
American Motors	
Clutch Housing-to-Starter	
4 Cyl.	54
6 Cyl.	18
Clutch Cover-to-Flywheel	
4 Cyl.	23
6 Cyl.	28
Clutch Housing-to-Engine	
4 Cyl.	54
6 Cyl.	
Top	27
Bottom	43
Transmission-to-Clutch Housing	55
Chrysler Corp.	
Clutch Housing-to-Engine	
$\frac{3}{8}$ " Bolts	30
$\frac{7}{16}$ " Bolts	50
Clutch Cover-to-Flywheel	
$\frac{5}{16}$ " Bolts	17
$\frac{3}{8}$ " Bolts	30
Clutch Housing Pan Bolts	17
Transmission-to-Clutch Housing	50