

## 2800 cc V6

## IDENTIFICATION CODING

## ENGINE IDENTIFICATION

Engine may be identified by the official Vehicle Identification Number. Number is stamped on metal tab fastened to instrument panel close to windshield on drivers side of car and visible from outside. The Identification number contains eleven digits. Example: 8H25Z100001. The first digit establishes model year and fifth digit engine identification.

Engine	Engine Code
2800 cc.....	Z

## ENGINE REMOVAL

See *Engine Removal at end of ENGINE Section.*

## CYLINDER HEAD &amp; MANIFOLDS

## INTAKE MANIFOLD

**Removal** — Drain cooling system, disconnect hose to water outlet and line from outlet to water pump. Remove distributor cap and wires as an assembly. Mark location of rotor and distributor housing, remove distributor. Disconnect throttle cables, then remove fuel line and filter, carburetor, rocker arm covers and EGR tube. Remove intake manifold nuts and bolts and remove intake manifold assembly.

**Installation** — Apply sealing compound to joining surfaces and position gasket on block. Tab on right bank cylinder head gasket must fit into cutout of manifold gasket. Install sealing compound to retaining bolt bosses on intake manifold. Install manifold on cylinder block. Install bolts and nuts, then tighten in sequence.

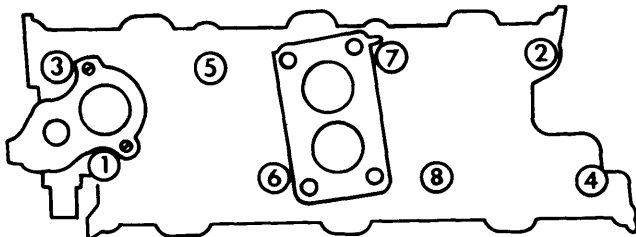

Fig. 1 Intake Manifold Tightening Sequence

## CYLINDER HEAD

**Removal** — Remove intake manifold. Remove rocker arm shaft (by loosening two bolts at a time in sequence), oil baffles and push rods. Remove exhaust manifold. Remove cylinder head bolts and lift cylinder head from block.

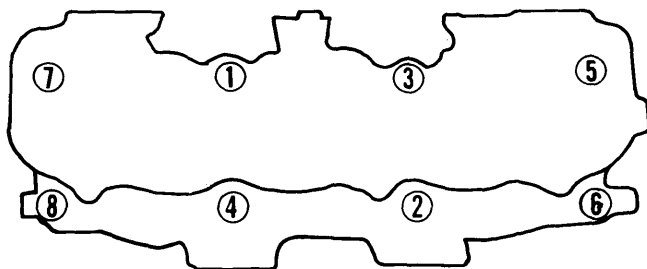

Fig. 2 Cylinder Head Tightening Sequence

**Installation** — Clean old gasket material from cylinder head and block. Install new cylinder head gaskets on block ensuring that "TOP" and "FRONT" markings on gasket are properly positioned. Position cylinder heads on block, install bolts and tighten in sequence.

## VALVES

## VALVE ARRANGEMENT

I-E-I-E-I (Left bank, front to rear).

I-E-I-E-I (Right bank, front to rear).

## VALVE GUIDE SERVICING

To ream guides for installation of valves with oversize stems, always use reamers in sequence and always reface valve seat after valve guide is reamed. Valve stems are available in .008", .016" and .032" oversize.

## VALVE STEM OIL SEALS

Cup or umbrella type seals used on all valves. Install seals with cup side down.

## VALVE SPRINGS

**Removal** — Remove rocker arm cover and spark plug on cylinder to be serviced. Install air line with adapter in spark plug hole. Remove rocker arm shaft and both push rods on cylinder to be serviced. Use suitable spring compressor (T72C-6565) to compress spring and remove retainer locks, spring retainer and valve springs. Remove and discard valve stem seal. **NOTE** — If air pressure fails to hold valve closed, remove cylinder head for inspection of valve seat.

**Installation** — Install new valve stem seal, valve spring (close coils toward cylinder head) and spring retainer. Compress spring and install retainer locks. Apply Lubriplate to both ends of push rod, rocker arm (valve and push rod ends) and valve stem tip.

## VALVE SPRING INSTALLED HEIGHT

Spring ends must be square within  $\frac{3}{64}$ ". Installed height of valve spring must not exceed specifications. Measure height from surface of cylinder head pad to underside of spring retainer. If height is greater than specified ( $1\frac{3}{64}$ "- $1\frac{39}{64}$ " ), install spacer on head under spring to bring height within limits.

**CAUTION** — Do not install spacers unless necessary.

## ROCKER ARM ASSEMBLY

Oil holes in shaft must face down upon installation (notch facing down). End plugs are installed cup side out in each end of shaft. Coat rocker arm pads with Lubriplate.

## MECHANICAL VALVE LIFTER ADJUSTMENT

1) Place finger on intake valve rocker arm for cylinder number 5 and rotate engine until valve just begins to open. Camshaft is now in correct position to adjust valves on number 1 cylinder. Set valve lash to specifications on both valves of number 1 cylinder.

2) Adjust valves of remaining cylinders in firing order (1-4-2-5-3-6) by positioning camshaft according to table.

## 2800 cc V6 (Cont.)

Adjust Both Valves For Cylinder No.	Intake Valve Just Opening For Cylinder No.
1.....	5
4.....	3
2.....	6
5.....	1
3.....	4
6.....	2

Engine	Valve Lash Clearance Intake (Cold)	Exhaust (Cold)
2800 cc .....	.014"	.016"

### PISTONS, PINS & RINGS

#### OIL PAN

See Oil Pan Removal at end of ENGINE Section.

#### PISTON & ROD ASSEMBLY

**NOTE** — New pistons must be installed in same cylinders for which they were fitted and used pistons in same cylinder from which they were removed.

**Removal** — With cylinder head and oil pan removed, use a suitable ridge cutter to remove any ridge or deposits on upper end of cylinder bore. **NOTE** — Piston must be at bottom of stroke and covered with cloth to collect cuttings. Inspect connecting rods and caps for cylinder identification and mark as necessary. Remove rod cap and push piston and rod assembly out top of cylinder block taking care not to nick crankshaft journal or cylinder wall.

**Installation** — Lightly coat cylinder bores, pistons and rings with engine oil. Ensure that ring gaps are properly spaced (see illustration) and install ring compressor on piston. Install each piston and rod assembly (with notch on piston head facing front of engine) in its respective bore and guide connecting rod onto crankshaft journal while tapping piston head with hammer handle to seat connecting rod against crankshaft. Install rod caps and tighten.

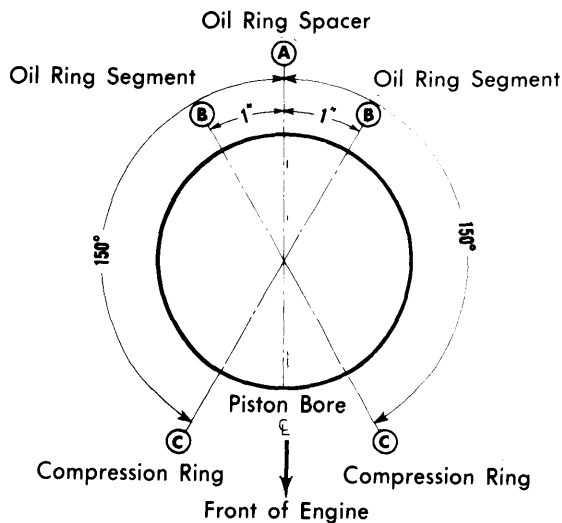

Fig. 3 Piston Ring Gap Spacing

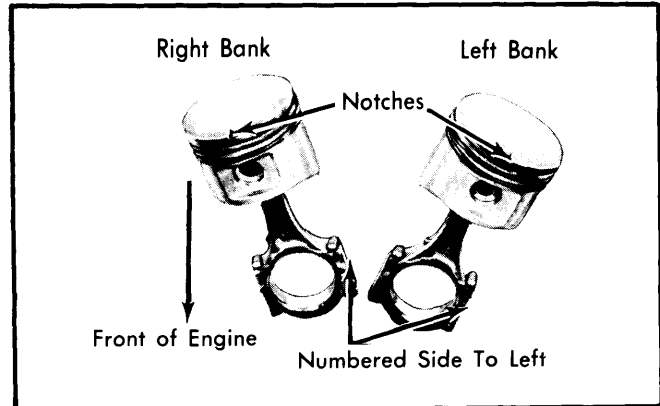

Fig. 4 Pistons and Connecting Rod Correctly Assembled

#### FITTING PISTONS

Measure piston at centerline of piston pin bore 90° to pin bore axis. Measure cylinder bore at right angles to centerline of crankshaft, below ring travel. If piston clearance is not within specifications, pistons are available in .020" oversize.

#### PISTON PINS

Pins are a press fit in connecting rod. Use suitable tool and arbor press for removal and installation. See Fig. 5. Piston pin should be centered in pin bore of piston.

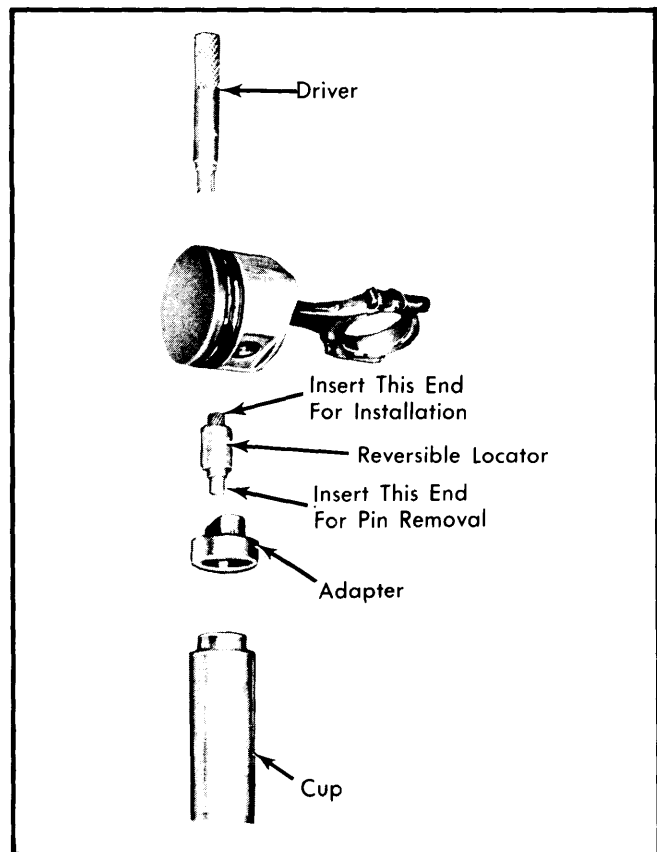

Fig. 5 Tool Set Up for Piston Pin Removal and Installation

## 2800 cc V6 (Cont.)

### CRANKSHAFT & ROD BEARINGS

#### MAIN & CONNECTING ROD BEARINGS

**NOTE** — Following procedures are with oil pan and oil pump removed.

**Connecting Rod Bearings** — After ensuring rod caps are marked for cylinder identification, remove rod caps. Use Plastigage method to check for proper bearing clearances. If not within specifications, new bearings must be installed. New bearings are available in .001" and .002" undersizes. Selective fitting is required on each connecting rod. A standard bearing may be used in combination with a .001" undersize, or a .002" undersize in combination with a .001" undersize.

**NOTE** — Always replace bearings in pairs. Never use a new bearing in combination with a used bearing. Coat bearing surfaces with oil, install rod cap and tighten nuts.

**Main Bearings** — 1) Position jack under counterweight adjoining bearing being checked so weight of crankshaft will not compress Plastigage and provide an erroneous reading. With all bearing caps (other than one being checked) tight, check clearances using Plastigage method.

2) If clearances are excessive, a .001" or .002" undersize bearing may be used in combination with a standard bearing. If .002" undersize bearings are used on more than one journal, they must be positioned in cylinder block rather than bearing cap. **NOTE** — Always replace bearings in pairs. Never use a new bearing in combination with a used bearing. If standard and .002" undersize combination do not bring bearing clearance within specified limits, crankshaft will have to be refinished and undersized bearings installed.

3) Remove all upper main bearings (except rear main) by inserting suitable tool in oil hole of crankshaft journal and rotating crankshaft clockwise to roll bearing from engine. Oil new upper bearing and insert plain (unnotched) end between crankshaft and indented (or notched) side of block. Rotate bearing into place. Install all main bearing caps with arrows pointing to front of engine. **NOTE** — If rear main bearing is to be replaced, engine must be removed from vehicle.

#### THRUST BEARING ALIGNMENT

Install all bearing caps except thrust bearing cap and tighten. Install thrust bearing cap with bolts finger tight. Pry crankshaft to front of engine and hold forward while prying thrust bearing cap to rear. Hold crankshaft forward and tighten bolts on thrust bearing cap. Check crankshaft endplay.

#### REAR MAIN BEARING OIL SEAL

**Removal** — Remove transmission, clutch pressure plate and disc (if equipped), flywheel, flywheel housing and rear plate. Remove old seal using two sheet metal screws.

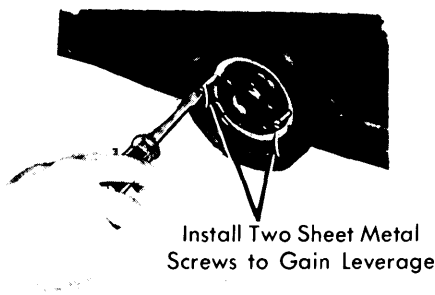

Fig. 6 Rear Main Oil Seal Removal

**Installation** — Coat seal to cylinder block surface of oil seal with oil. Coat seal contact surface of oil seal and crankshaft with Lubriplate. Start seal in recess and install with suitable tool (T72C-6165). Drive seal into position until firmly seated.

### CAMSHAFT

#### ENGINE FRONT COVER

**Removal** — Drain cooling system and crankcase. Remove radiator, fan shroud and oil pan. Remove A/C compressor and bracket (if equipped), alternator, drive belts, fan and water pump. Remove drive pulley from crankshaft. Remove front cover bolts and cover. If front cover plate gasket needs replacement, remove two screws and plate. Remove guide sleeves from cylinder block (if necessary).

**Installation** — 1) Clean all gasket mating surfaces. Apply suitable sealing compound to block and back side of front cover plate. Position gasket and front cover plate on cylinder block.

2) Temporarily install four front cover screws to position gasket and cover plate, then install and tighten two cover plate attaching screws. Remove alignment bolts and fit new seal rings to guide sleeves (no sealer used).

3) Insert sleeves in block with chamfered side of sleeve toward front cover. Apply suitable sealer to front cover gasket, then position gasket and front cover on block. Use suitable tool (T74P-6019A) inserted in front cover oil seal to align cover. Install bolts and tighten.

4) Coat new seal with lubriplate. Slide suitable tool (T74P-6700A) and seal onto crankshaft. Drive seal in until tool butts against front cover.

#### FRONT COVER OIL SEAL

Seal may be replaced with front cover installed on vehicle. Proceed as follows:

1) Drain cooling system and remove radiator, crankshaft pulley and water pump drive belt. Use suitable puller (1175-AB) to remove seal.

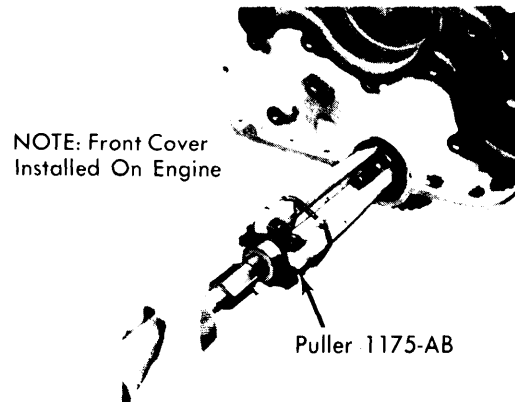

Fig. 7 Front Cover Oil Seal Removal

2) Coat new seal with Lubriplate. Slide suitable tool (T74P-6700A) and seal onto crankshaft. Drive seal in until tool seats against front cover.

## 2800 cc V6 (Cont.)

### TIMING GEARS

Using a dial indicator, check that backlash between camshaft gear and crankshaft gear is .006-.010". If backlash exceeds specification, replace BOTH gears as follows:

**Removal** — Drain cooling system and crankcase. Remove radiator, oil pan and engine front cover. Remove camshaft gear retaining bolt and slide gear off camshaft. Use suitable gear puller and remove crankshaft gear.

**Installation** — Turn camshaft and crankshaft as necessary to align timing marks. See Fig. 2. Install camshaft gear. Install crankshaft gear keyway up. Recheck timing marks to make sure they are still aligned.

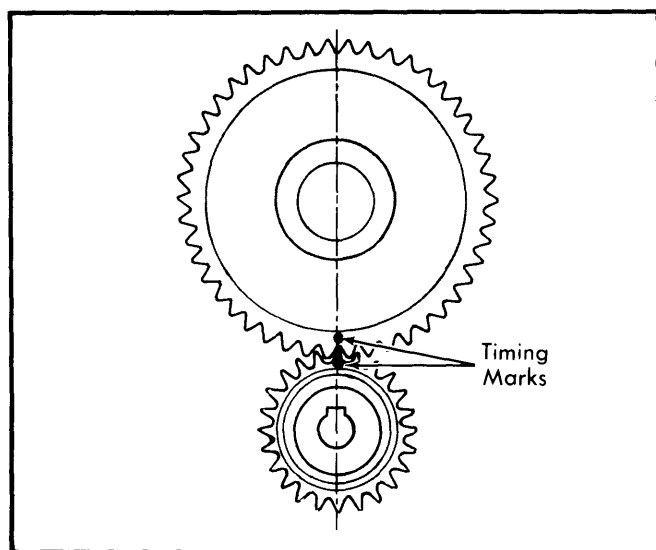

Fig. 8 Timing Gear Marks Aligned with Crankshaft Keyway Facing Up

### CAMSHAFT

**Removal** — Remove engine front cover, intake manifold and alternator. Remove rocker arm shaft and push rods, marking push rods for installation in original location. Remove camshaft gear bolt and slide gear from camshaft. Remove thrust plate and screws. Remove valve lifters using a magnet. Carefully remove camshaft from block.

**Installation** — Oil camshaft journals with engine oil and apply Lubriplate to cam lobes. Carefully install camshaft in engine. Install spacer ring (chamfered side toward camshaft), camshaft key and thrust plate (covering main oil gallery). Reverse removal procedure for remaining parts.

### CAMSHAFT BEARINGS

**Removal** — With engine removed from vehicle, remove flywheel, camshaft and rear bearing bore plug. Use suitable collet and back-up nut assembled on expanding mandrel to remove bearings.

**Installation** — Position new bearings at bearing bores and press into place using correct size expanding collet being sure to center pulling plate and puller screw to avoid damage to bearing. Align oil holes in cylinder block when bearings are installed. Front edge of No. 1 bearing must be installed .040-.060" below front face of cylinder block.

### CAMSHAFT END THRUST

Rocker arm shaft assembly must be loosened sufficiently to free camshaft. Push camshaft toward rear of engine and install dial indicator so point is on camshaft sprocket bolt. Zero indicator. Position screwdriver between camshaft gear and block, pull camshaft forward and release. If endplay is excessive, replace thrust plate. **CAUTION** — Do not attempt to pry camshaft back and forth with valve train load on camshaft.

### CAM LOBE LIFT

Check lift of each camshaft lobe in consecutive order as follows:

1) Remove rocker arm shaft assembly and make sure each push rod is in valve lifter socket. Install dial indicator so ball socket adapter of indicator rests on end of push rod and in same plane as push rod movement. With an auxiliary starter switch connected to starter solenoid and ignition switch "OFF", bump crankshaft until tappet is on base circle of camshaft lobe (push rods lowest point).

2) Zero dial indicator and continue to rotate crankshaft until push rod is in fully raised position (highest indicator reading). Compare total lift from indicator readings with specifications. If lift on any lobe is .005" less than specifications, valve lifters are operating on worn lobes.

## ENGINE OILING

**Crankcase Capacity** — 5 quarts which includes ½ quart with filter replacement.

**Oil Filter** — Change filter at first oil change and at alternate oil changes after that.

**Normal Oil Pressure (Hot)** — 40-60 psi @ 2000 RPM.

**Pressure Regulator Valve** — In pump body, not adjustable.

### ENGINE OILING SYSTEM

The V6 engine is pressure fed by a rotor type oil pump, which filters all oil through a full flow filter before entering engine. An oil gallery supplies oil to crankshaft main bearings, from there through slanted passages in crankshaft to connecting rod journals. Connecting rod big ends have a squirt hole which sprays oil on thrust side of cylinder bores. Oil from the oil gallery also feeds camshaft main bearings, which have grooves 180° of their circumference. From these grooves, passages lead to distributor drive gear and rocker arm shafts.

### OIL PUMP

**Disassembly** — Remove pick-up tube and screen assembly from pump housing. Remove cover and lift out two-piece rotor assembly. Drill a small hole and insert self-threading sheet metal screw into oil pressure relief valve plug and remove plug. Remove spring and valve.

**Reassembly** — Clean, inspect (see specifications) and oil all parts. Install relief valve, spring and new plug in oil pump housing. Install plug with flat side pointing out and spread

# Ford Motor Co. V6 Engines

## 2800 cc V6 (Cont.)

plug in housing using a drift. Install inner and outer rotors and shaft assembly in housing with dot reference marks up. Install cover and pick-up tube assembly.

### Oil Pump Specifications

**Application**

**Specification**

Outer Race-to-Housing Clearance.....	.001-.013"
Rotor Endplay .....	.004" Max.
Shaft-to-Housing Clearance.....	.0015-.0030"
Relief Valve-to-Bore Clearance .....	.0015-.0030"
Relief Valve Spring Pressure .....	13.6-14.7 Lbs. @ 1.39"

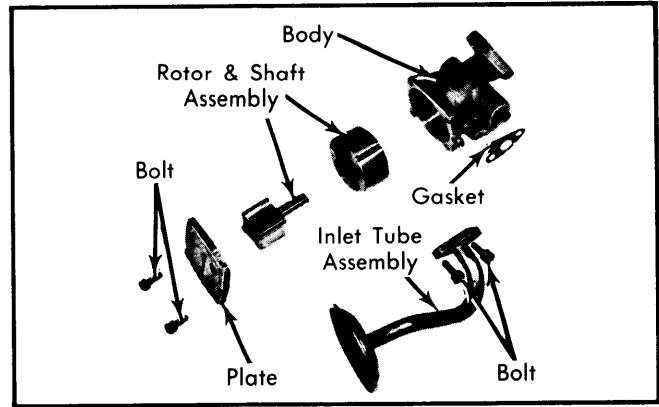

Fig. 9 Exploded View of Oil Pump Assembly

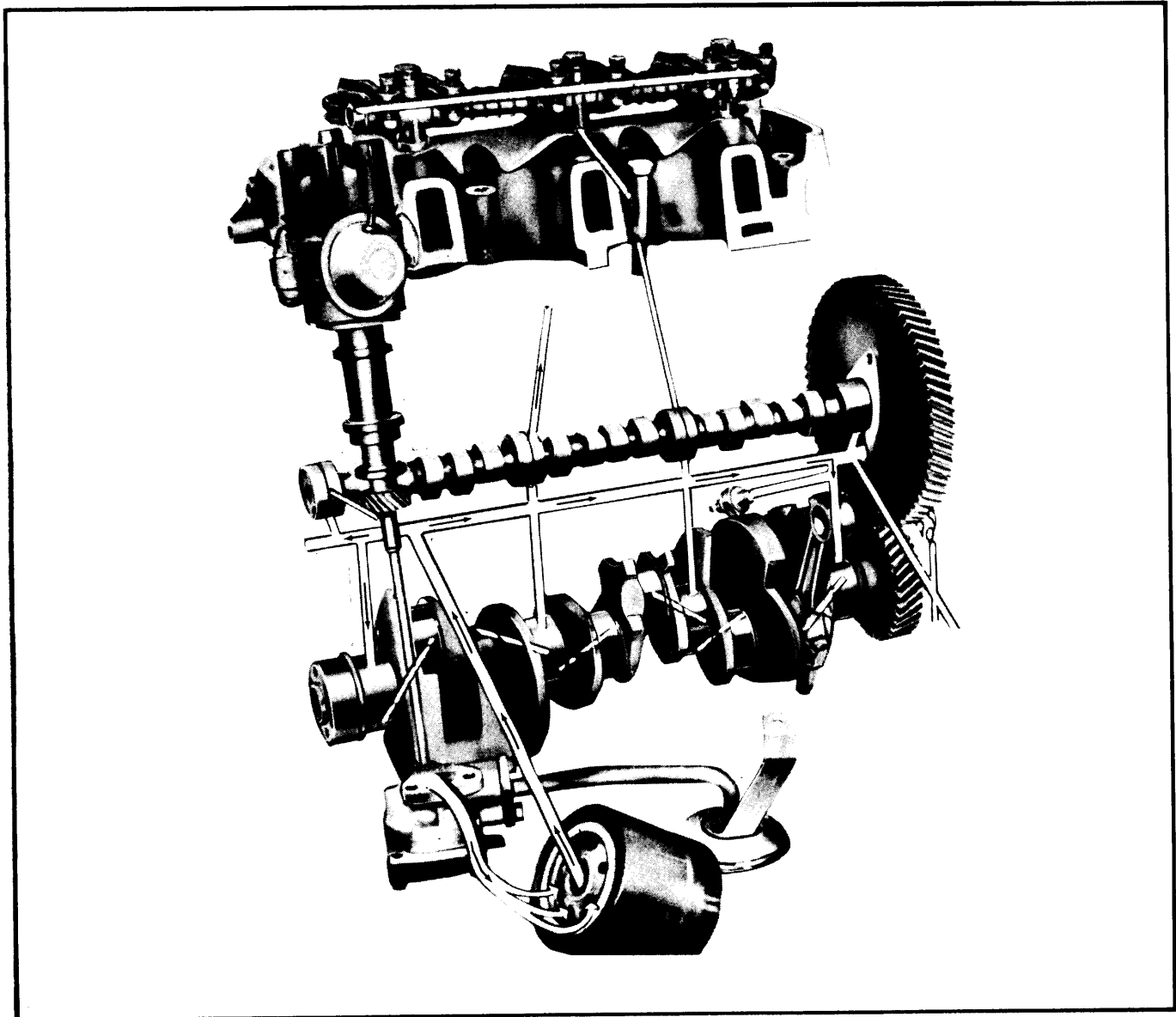

Fig. 10 Engine Oiling System

## 2800 cc V6 (Cont.) ENGINE SPECIFICATIONS

GENERAL SPECIFICATIONS						
Engine	Net HP At RPM	Torque (Ft. Lbs. at RPM)	Compr. Ratio	Bore	Stroke	Displ. Cu. Ins.
2800 cc	90@4200	143@2200	8.7-1	3.66"	2.70"	170.8

VALVES							
Engine & Valve	Head Diam.	Face Angle	Seat Angle	Seat Width	Stem Diameter ①	Stem Clearance	Valve Lift
2800 cc							
Int.	1.570"	44°	45°	.060-.079"	.3159-.3167"	.0008-.0025"	.373"
Exh.	1.269"	44°	45°	.060-.079"	.3153"	.0018-.0035"	.373"

① Available in .008", .016" and .032" Oversize

VALVE SPRINGS			
Engine	Free Length	PRESSURE (LBS.)	
		Valve Closed	Valve Open
2800 cc	1.9"	60-68@1.585"	138-149@1.222"

CAMSHAFT			
Engine	Journal Diam.	Clearance ①	Lobe Lift
2800 cc			
No. 1	1.6501"	.0010-.0026"	.2555"
No. 2	1.6351"		
No. 3	1.6201"		
No. 4	1.6051"		

① — End play is .0008-.004".

PISTONS, PINS, RINGS						
Engine	PISTONS		PINS		RINGS	
	Clearance	Piston Fit	Rod Fit	Rings	End Gap	Side Clearance
2800 cc	.0011-.0019"	.0003-.0006"	Press Fit	Comp. Oil	.015-.023" .015-.055"	.0020-.0033" Snug

CRANKSHAFT MAIN & CONNECTING ROD BEARINGS							
Engine	MAIN BEARINGS				CONNECTING ROD BEARINGS		
	Journal Diam.	Clearance	Thrust Bearing	Crankshaft Endplay	Journal Diam.	Clearance	Sideplay
2800 cc	2.2433-2.2441"	.0008-.0015"	No. 3	.004-.008"	2.1252-2.1260"	.0006-.0015"	.004-.011"

TIGHTENING SPECIFICATIONS			
Application	Ft. Lbs.	Application	Ft. Lbs.
Camshaft Gear.....	30-36	Main Bearing Cap.....	65-75
Camshaft Thrust Plate.....	12-15	Oil Pan.....	5-7
Connecting Rod Cap.....	21-25	Water Pump.....	6-9
Crankshaft Damper.....	92-103	Engine Front Cover.....	12-15
Cylinder Head..... ①		Oil Pump.....	12-15
Exhaust Manifold.....	20-30	Rocker Arm Shaft.....	43-49
Flywheel.....	47-51	① — Step one 40 ft. lbs., step two 50 ft. lbs., step three 65-80 ft. lbs.	
Fuel Pump.....	12-15	② — Step one 6 ft. lbs., step two 11 ft. lbs., step three 16 ft. lbs., step four 15-18 ft. lbs. Retorque to final value after engine has been operated.	
Intake Manifold			
Bolt or Nut..... ②			
Stud.....	10-12		