

2300 cc 4 CYLINDER

IDENTIFICATION CODING

ENGINE IDENTIFICATION

Engine may be identified from the official Vehicle Identification Number. Number is stamped on a metal tab fastened to instrument panel close to windshield on drivers side of car and visible from outside. The Identification number contains eleven digits. Example: 8S10Y100001. The first digit establishes model year and fifth digit engine identification.

Engine	Engine Code
2300 cc.....Y	

ENGINE REMOVAL

See *Engine Removal* at end of *ENGINE* Section.

CYLINDER HEAD & MANIFOLDS

INTAKE MANIFOLD

Removal — Remove air cleaner and disconnect fuel line from carburetor. Disconnect vacuum lines and crankcase ventilation hose at intake manifold. Remove attaching nuts and lift manifold, carburetor and decel valve off as an assembly.

Installation — Clean gasket material from cylinder head and manifold. Install new gasket on cylinder head and install manifold. Tighten nuts to specification in sequence shown in illustration.

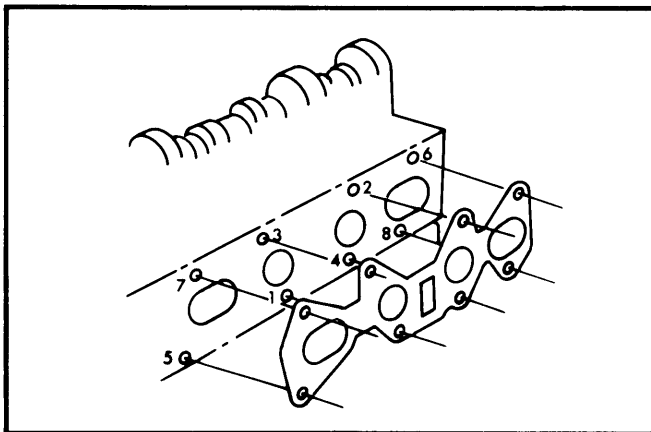

Fig. 1 2300 cc Intake Manifold Tightening Sequence

EXHAUST MANIFOLD

Removal — Remove air cleaner and two attaching nuts from top of exhaust manifold shroud. Remove attaching nuts from muffler inlet pipe and manifold and remove exhaust manifold.

Installation — Apply light film of graphite grease on exhaust manifold and install manifold. Tighten nuts to specification in sequence shown in illustration.

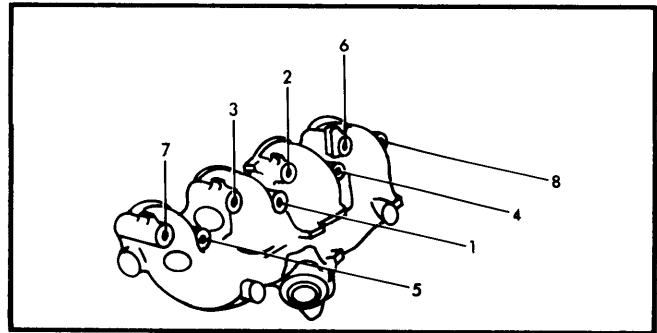
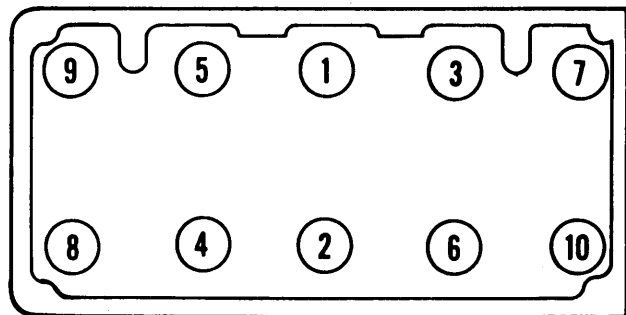

Fig. 2 2300 cc Exhaust Manifold Tightening Sequence

CYLINDER HEAD

Removal — Drain cooling system, remove air cleaner and rocker arm cover. Remove exhaust manifold, intake manifold, carburetor and decel valve. Remove camshaft drive belt cover. Loosen drive belt tensioner and remove belt. Remove water outlet elbow from cylinder head. Remove bolt from inner cover to cylinder head. Remove bolts and lift head and camshaft assembly from engine.

Installation — Clean gasket material from cylinder head and block. Install new gasket on block. Place cylinder head assembly on block and install head bolts. Tighten bolts in two steps in sequence (see illustration).



← Front

Fig. 3 2300 cc Cylinder Head Tightening Sequence

VALVES

VALVE ARRANGEMENT

E-I-E-I-E-I-E-I

VALVE GUIDES

If valve guides become worn they may be reamed to install a new valve with oversize stem. When going from a standard size stem to oversize, always use reamers in sequence to obtain final desired bore. Valve seat must be refaced after guide has been reamed, and a suitable tool used to break sharp corner (ID) of guide.

2300 cc 4 CYLINDER (Cont.)

VALVE STEM OIL SEALS

With valve in head, place plastic installation cap over end of valve stem. Start stem seal carefully over cap and push seal down until jacket touches top of valve guide. Remove plastic cap and bottom seal on valve guide.

VALVE SPRINGS

Removal — Remove exhaust manifold shroud and valve rocker arm cover. Remove both rocker arms (cam followers) from cylinder being serviced. Remove spark plug from cylinder and install air line and adapter to cylinder with a minimum of 140 psi line pressure. **NOTE** — If air pressure does not hold valve shut, remove cylinder head for inspection. Use suitable tool to compress valve spring and remove retainer locks, spring retainer valve spring. Remove and discard valve stem seal. **CAUTION** — Do not remove air pressure.

Installation — Install new valve stem oil seal, valve spring and retainer. Compress spring and install valve spring retainer locks. **CAUTION** — Do not compress spring more than is necessary to install locks. Remove compressor tool, turn off air and remove adapter. Apply Lubriplate to all contact surfaces of rocker arms and install in position.

NOTE — Make sure that the hydraulic lifters have been collapsed and released before rotating camshaft.

VALVE SPRING INSTALLED HEIGHT

Measure assembled height of valve spring from surface of spring pad to underside of spring retainer. If height is not within specifications, install .030" spacer(s) between spring and pad to obtain recommended height. Do not install spacers unless necessary, as excess use of spacers will result in overstressing valve springs and overloading camshaft lobe.

Spring Height Specifications

Engine	Installed Height
2300 cc.....	1 $\frac{17}{32}$ "-1 $\frac{1}{32}$ "

HYDRAULIC LIFTER ASSEMBLY

Two types of hydraulic lash adjusters are used in 2300 cc engines. Clean and inspect all parts of assembly. Replace the entire assembly if plunger is not free in body. Assemble lifter assembly and check free operation by pressing down on cap. Lifters may also be checked with hydraulic tester to check leak down rate.

HYDRAULIC LIFTER ADJUSTMENT

Position camshaft so high point of cam lobe is facing away from valve (valve closed) to be checked. Remove coil spring holding cam follower arm to lash adjuster (if equipped). Use suitable tool (T74P-6565-B) to slowly apply pressure to cam follower until lash adjuster is completely collapsed. Hold in this position and check clearance between follower and cam. If not within specifications (.035"-.055") inspect cam follower, valve spring installed height, and cam.

PISTONS, PINS & RINGS

OIL PAN

See Oil Pan Removal at end of ENGINE Section.

PISTON & ROD ASSEMBLY

Removal — Remove ridge at top of cylinder bores using suitable ridge reamer before removing pistons from block. **NOTE** — Keep tops of pistons covered during this procedure. Rotate crankshaft and inspect connecting rods and rod caps for cylinder identification. Identify them if necessary. Remove rod cap and push each piston and rod assembly out top of cylinder bore. **NOTE** — Be careful not to nick crankshaft journals. Install rod caps on mating rods.

Installation — 1) Oil piston rings and cylinder walls with light engine oil. Ensure that ring gaps are properly spaced on piston. See Fig. 4. Install ring compressor on piston.

2) Insert rod and piston assembly into cylinder bore and guide rod over crankshaft journal. **NOTE** — Notch or arrow on piston head should be towards front of engine. Tap piston into cylinder bore using a wooden handle, install rod cap and tighten. Repeat procedure for each piston assembly.

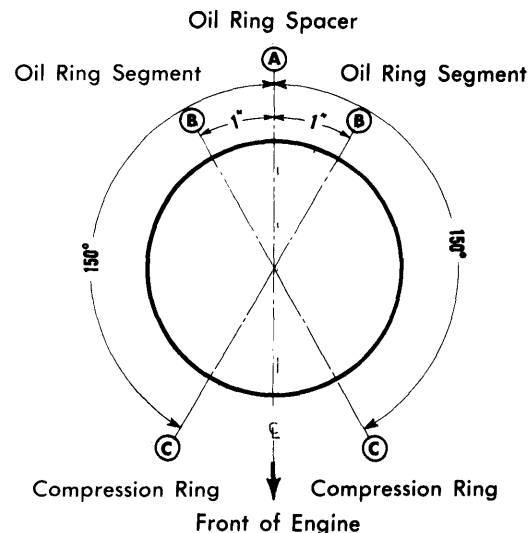

Fig. 4 Piston Ring Gap Spacing

FITTING PISTONS

Check piston to cylinder bore clearance by measuring the piston and bore diameters. Measure outer diameter of piston at centerline of piston pin bore and at 90° to pin bore axis. Oversize pistons are available.

PISTON PINS

Removal — Remove bearing inserts from connecting rod and cap. Mark pistons and pins to assure assembly with same rod. Press piston pin from piston and connecting rod.

Installation — Apply light coat of engine oil to all parts. Assemble piston to connecting rod with oil squirt hole (in connecting rod), and arrow or notch (on top of piston), positioned as shown in illustration. Start piston pin in piston and connecting rod and press pin through piston and connecting rod until pin is centered in piston.

2300 cc 4 CYLINDER (Cont.)

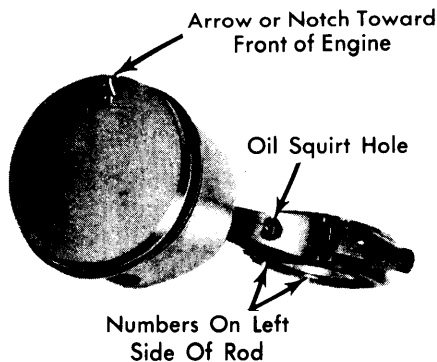

Fig. 5 Instructions for Piston-to-Rod Assembly

CRANKSHAFT & ROD BEARINGS

MAIN & CONNECTING ROD BEARINGS

NOTE — Following procedures are with oil pan and oil pump removed.

Connecting Rod Bearings — After ensuring rod caps are marked for cylinder identification, remove rod caps. Use Plastigage method to check for proper bearing clearances. If not within specifications, new bearings must be installed. New bearings are available in .001" and .002" undersizes. Selective fitting is required on each connecting rod. A standard bearing may be used in combination with a .001" undersize, or a .002" undersize in combination with a .001" undersize. **NOTE** — Always replace bearings in pairs. Never use a new bearing in combination with a used bearing. Coat bearing surfaces with oil, install rod cap and tighten nuts.

Main Bearings — 1) Position jack under counterweight adjoining bearing being checked so weight of crankshaft will not compress Plastigage and provide an erroneous reading. With all bearing caps (other than one being checked) tight, check clearances using Plastigage method.

2) If clearances are excessive, a .001" or .002" undersize bearing may be used in combination with a standard bearing. If .002" undersize bearings are used on more than one journal, they must be positioned in cylinder block rather than bearing cap. **NOTE** — Always replace bearings in pairs. Never use a new bearing in combination with a used bearing. If standard and .002" undersize combination do not bring bearing clearance within specified limits, crankshaft will have to be refinished and undersized bearings installed.

3) Remove all upper main bearings by inserting suitable tool in oil hole of crankshaft journal and rotating crankshaft clockwise to roll bearing from engine. Oil new upper bearing and insert plain (unnotched) end between crankshaft and indented (or notched) side of block. Rotate bearing into place. Install all main bearing caps with arrows pointing to front of engine.

REAR MAIN BEARING OIL SEAL

Removal & Installation — 1) Split lip type seal is provided for service replacement. Loosen all main bearing cap bolts, allowing crankshaft to drop (not more than $\frac{1}{32}$ ") and remove rear main bearing cap. Remove oil seal from cap and clean oil seal groove. Remove upper seal half from block using seal removal tool or small metal screw in end of seal. **CAUTION** —

Extreme care should be taken not to scratch or mar crankshaft seal surface.

2) Dip new split lip type seal halves in clean engine oil. Carefully install upper seal into its groove with undercut side of seal toward front of engine, by rotating it on seal journal of crankshaft until approximately $\frac{3}{8}$ " protrudes below parting surface. **CAUTION** — Be sure no rubber has been shaved from outside diameter of seal. Tighten remaining bearing caps. Install lower seal in rear main bearing cap with undercut side of seal toward front of engine. Allow seal to protrude approximately $\frac{3}{8}$ " above parting surface to mate with upper seal. **NOTE** — Locating tab must face rear of engine. Apply suitable sealer to rear main bearing cap mating surfaces, taking care to not permit sealer on seal, install main bearing cap and tighten.

FRONT CRANKSHAFT OIL SEAL

Removal & Installation — Remove alternator belt and crankshaft pulley. Remove camshaft drive belt (see Camshaft Drive Belt). Remove drive belt sprocket and belt guide from crankshaft (if equipped). Use suitable tool (T74P-6150-A or T-74P-6700-B) to remove and replace oil seal.

CAMSHAFT

CAMSHAFT DRIVE BELT

Removal & Installation — See Camshaft Timing.

CAMSHAFT

Removal — With cylinder head removed from engine, remove rocker arms. **NOTE** — Keep rocker arms in order for reinstallation in original position. Remove camshaft sprocket attaching bolt. Slide sprocket and belt guide plate from camshaft. Remove camshaft thrust plate from rear of cylinder head and carefully slide camshaft out.

Installation — Oil camshaft with engine oil and apply Lubriplate to valve stem tips. Oil rocker arms and carefully install camshaft in cylinder head. Install thrust plate, bolts and tighten. Check camshaft endplay and replace thrust plate if endplay not within specifications. **NOTE** — Use new camshaft attaching bolt or use new Teflon tape on threads of old bolt.

CAMSHAFT BEARINGS

Removal & Installation — Use suitable tool (71P-6250A) to remove and install bearings. **NOTE** — Lube hole in bearing must be aligned with oil hole in journal.

CAMSHAFT END THRUST

With camshaft drive belt cover removed, push camshaft toward rear of engine. Install dial indicator so indicator point is on camshaft sprocket attaching screw or gear hub and zero dial indicator. Using a large screwdriver between camshaft sprocket or gear and cylinder head, pull the camshaft forward and release it. Read dial indicator and if end play is not within specifications, replace thrust plate at rear of cylinder head.

CAM LOBE LIFT

Measure distance between major and minor diameters of each cam lobe with a micrometer. Difference in readings is lobe lift. If readings vary, or do not meet specifications, replace camshaft.

2300 cc 4 CYLINDER (Cont.)

CAMSHAFT TIMING

Checking Timing — Remove access plug from belt cover and position crankshaft to TDC by aligning pointer on cover with "O" mark on crankshaft damper. **CAUTION** — Turn engine in direction of normal rotation only. Look through access hole and check that timing mark on camshaft drive sprocket is aligned with pointer on inner belt cover. Remove distributor cap and check that rotor is facing number one position on cap.

Adjusting Timing — 1) If timing is incorrect or it is necessary to remove belt, remove timing belt outer cover and loosen belt tensioner adjustment screw. Position tension adjusting tool on tension spring roll pin and release belt tensioner. Tighten adjustment screw to hold tensioner in released position. Remove crankshaft damper, belt guide and drive belt.

2) Position crankshaft sprocket and camshaft sprocket as shown in Fig 6. Remove distributor cap and set rotor to No. 1 firing position by turning auxiliary shaft. Install drive belt over crankshaft sprocket and then counterclockwise over auxiliary and camshaft sprockets. Align belt in middle of sprockets.

3) Loosen tensioner adjustment screw and allow tensioner to move against drive belt. Remove spark plugs and rotate crankshaft two complete turns in direction of normal rotation to remove slack from belt. Tighten tensioner adjustment and pivot bolts. Recheck timing mark alignment.

AUXILIARY SHAFT

Removal — Remove drive belt cover, drive belt and auxiliary sprocket retaining bolt and washer. Slide sprocket from auxiliary shaft. Remove distributor, fuel pump and auxiliary shaft

cover. Remove thrust plate and carefully remove shaft from cylinder block. Remove bearing from block, if worn or damaged, using suitable tool.

Installation — Align oil holes in bearing with those in block and drive bearing into place using a suitable tool. Oil shaft with engine oil and slide into cylinder block. **CAUTION** — Do not allow gear and fuel pump eccentric to touch bearing surfaces during installation. Install thrust plate, gasket and shaft cover, fuel pump, distributor and sprocket. Install and adjust drive belt. Install drive belt cover.

ENGINE OILING

Crankcase Capacity — 4 quarts. Add 1 quart with filter change.

Oil Filter — Replace at first oil change and every second oil change after that.

Normal Oil Pressure (Hot) — 40-60 psi at 2000 RPM.

Pressure Regulator Valve — In pump body. Not adjustable.

ENGINE OILING SYSTEM

Oiling system is force feed type using a full flow oil filter. Oil enters main oil gallery from the oil filter and flows to main bearings and camshaft bearings. Connecting rod bearings are supplied from front and rear main bearings via inclined passages. A squirt hole in each rod bearing end supplies oil to piston thrust side of a cylinder. The auxiliary shaft is connected with the main oil gallery.

The distributor shaft receives oil from a passage drilled in the auxiliary shaft. Cam and cam follower arms are supplied from camshaft bearings and valve lash adjusters are oiled from drilled oil passages in cylinder head.

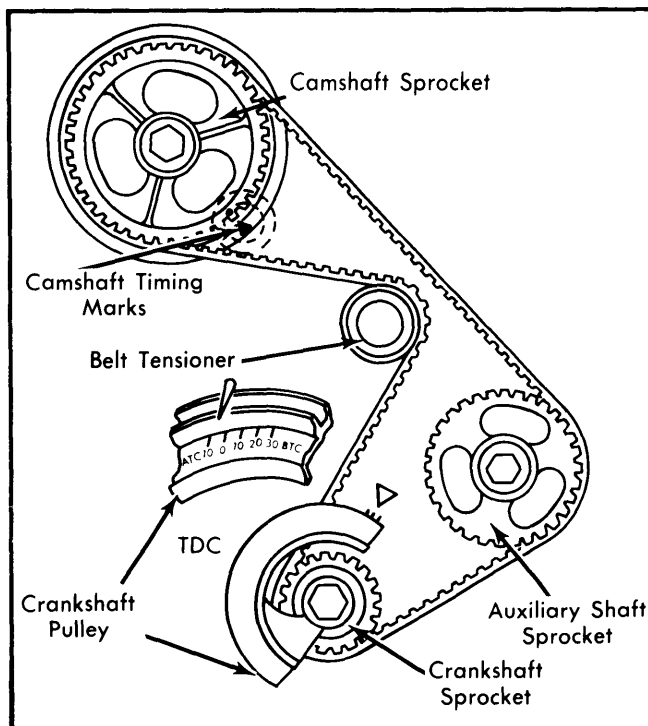

Fig. 6 Camshaft Belt Sprocket Alignment

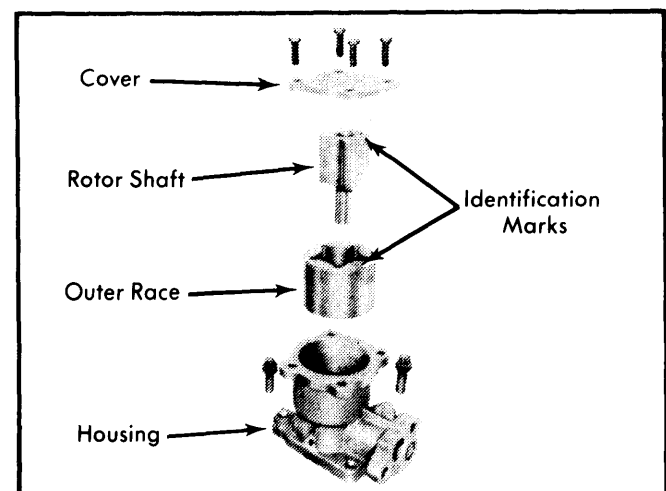

Fig. 7 Disassembled View of 4 Bolt Oil Pump

2300 cc 4 CYLINDER (Cont.)

OIL PUMP

NOTE — Under no circumstances should the oil pump be disassembled if it is the three bolt type where the outboard bearing is in the cover. If found to be out of specification, replace as a unit. A four bolt oil pump is also used, and this pump may be serviced.

Removal — Remove oil pan and separate pick-up tube and screen from body of pump. Remove oil pump attaching screws and remove pump.

Disassembly (4 Bolt Pump Only) — Remove pick-up tube gasket and cover attaching screws. Remove cover, inner rotor and shaft assembly, then remove outer race. Drill a small hole and insert sheet metal screw into oil pressure relief valve chamber cap and pull cap. Remove spring and plunger.

Reassembly (4 Bolt Pump Only) — Oil parts thoroughly and install oil pressure relief valve plunger, spring and a new cap. Install outer race and inner rotor and shaft assembly.

NOTE — Make sure identification mark (dimple) on outer race is facing outward and on same side as mark on rotor. Rotor assembly and race are serviced as an assembly only. Install cover and tighten attaching screws.

Installation — To install, reverse removal procedure and use a new pick-up tube gasket.

Oil Pump Specifications

Application	Specification
Drive Shaft-to-Bearing0015-.0030"
Rotor Assembly End Clearances004" Max.
Outer Rotor-to-Housing001-.013"
Relief Valve Spring	
Tension	15.2-17.2 lbs. @1.20"
Clearance0015-.0030"

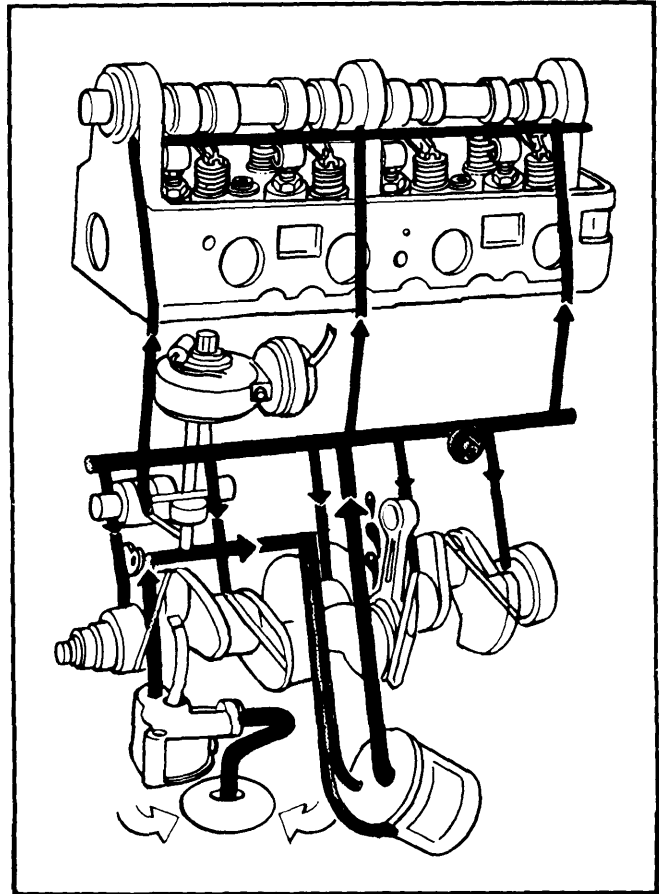

Fig. 8 Engine Oiling Circuit Shown

ENGINE SPECIFICATIONS

GENERAL SPECIFICATIONS						
Engine	Net HP At RPM	Torque (Ft. Lbs. at RPM)	Compr. Ratio	Bore	Stroke	Displ. Cu. Ins.
2300 cc	88@4800	118@2800	9.0-1	3.78"	3.126"	140.0

VALVES							
Engine & Valve	Head Diam.	Face Angle	Seat Angle	Seat Width	Stem Diameter	Stem Clearance	Valve Lift
2300 cc Int.	1.736"	44°	45°	.060-.080"	.3416-.3423"	.0010-.0027"	.3997"
Exh.	1.500"	44°	45°	.070-.090"	.3411-.3418"	.0015-.0032"	.3997"

PISTONS, PINS, RINGS						
Engine	PISTONS		PINS		RINGS	
	Clearance	Piston Fit	Rod Fit	Rings	End Gap	Side Clearance
2300 cc	.0014-.0022"	.0002-.0004"	Press Fit	1 & 2 3	.010-.020" .015-.055"	.002-.004" Snug

2300 cc 4 CYLINDER (Cont.)

ENGINE SPECIFICATIONS (Cont.)

CRANKSHAFT MAIN & CONNECTING ROD BEARINGS							
Engine	MAIN BEARINGS				CONNECTING ROD BEARINGS		
	Journal Diam.	Clearance	Thrust Bearing	Crankshaft Endplay	Journal Diam.	Clearance	Sideplay
2300 cc	2.3982-2.3990"	.0008-.0015"	No. 3	.004-.008"	2.0464-2.0472"	.0008-.0015"	.0035-.0105"

VALVE SPRINGS			
Engine	Free Length	PRESSURE (LBS.)	
		Valve Closed	Valve Open
2300 cc	1.82"	71-79 @ 1.56	180-198 @ 1.16

CAMSHAFT			
Engine	Journal Diam.	Clearance	Lobe Lift
2300 cc	1.7713-1.7720"	.001-.003"	.2437"

TIGHTENING SPECIFICATIONS

Application	Ft. Lbs.
Auxiliary Shaft Sprocket	28-40
Auxiliary Shaft Thrust Plate	6-9
Belt Tensioner Bolt	①28-40
Camshaft Sprocket	80-90
Camshaft Thrust Plate	6-9
Connecting Rod	④30-36
Crankshaft Pulley.....	100-120
Cylinder Head	②80-90
Exhaust Manifold	③16-23
Flywheel	54-64
Fuel Pump	14-21
Intake Manifold	③14-21
Main Bearing Caps	②80-90
Oil Pan	⑤6-8
Timing Belt Cover	6-9

① - Specification is for pivot bolt. Adjustment bolt torque is 14-21 ft. lbs.
 ② - Tighten in two steps as follows: Step 1 - 60 ft. lbs., Step 2 - 80-90 ft. lbs.
 ③ - Tighten in two steps as follows: Step 1 - 5-7 ft. lbs., Step 2 - 14-21 lbs.
 ④ - Tighten in two steps as follows: Step 1 - 25-30 ft. lbs., Step 2 - 30-36 ft. lbs.
 ⑤ - Specification is for 6 mm bolt. For 8 mm bolts, tighten to 8-10 ft. lbs.