

225" 6 CYLINDER

IDENTIFICATION CODING

ENGINE IDENTIFICATION

Engine serial number is stamped on right side of block below number 6 spark plug. This number can contain as many as fifteen characters and digits.

8225R21017A

1st Digit – Model Year (8-1978)

2nd,3rd,&4th Digit – Engine Displacement

5th Letter – Engine Usage[Ⓛ]

6th Digit – Build Shift

7th,8th,9th&10th Digit – Build Date

Last Letter – Oversize Cylinder Bore

Ⓛ – Two letters may be used to decode usage.

SPECIAL ENGINE MARKS

Information identifying undersize crankshaft, oversized tappets, low compression, oversized cylinder bores, engine built that day and shift are stamped at various locations on block.

M – (**M-2-3** ..) Indicate .001" undersize No. 2 & 3 Main bearing journals.

R – (**R-1-4** ..) Indicate .001" undersize No. 1 & 4 Connecting rod journals.

M-10 – Indicate .010" undersize ALL main bearing journals.

R-10 – Indicates .010" undersize all connecting rod journals. These codes are stamped on center crankshaft counterweight.

A – Indicates .020" oversize cylinder bores. Located top of front pad right side of block.

♦ – Indicates .008" oversize tappets. Located top of front pad right side of block.

O/S – Indicates .005" oversize valve stems. Located front of head on thermostat boss.

E – Indicates cast iron crankshaft. Located on identification pad below No. 6 spark plug.

ENGINE REMOVAL

See *Engine Removal* at end of *ENGINE* Section.

CYLINDER HEAD & MANIFOLDS

MANIFOLD ASSEMBLY

Removal – Disconnect all hoses and lines from air cleaner and remove air cleaner. Remove carburetor air heater and disconnect all lines and linkage to carburetor and remove carburetor. Disconnect exhaust pipe at manifold. Remove nuts and washers securing manifold assembly to cylinder head and remove manifold. Remove three screws securing intake manifold to exhaust manifold and separate manifolds.

Installation – Install new gasket between intake and exhaust manifold and install three screws securing manifolds together. Do not tighten screws at this time. Position manifold assembly on cylinder head using a new gasket. Install washers with cup side against manifold and snug all nuts. Tighten three intake to exhaust screws starting with inner screw. Start at center of manifold assembly and work outward, tightening manifold nuts. Reinstall carburetor, linkage, hoses and air cleaner.

CYLINDER HEAD

Removal – Drain cooling system and disconnect necessary wires, hoses and linkage. Remove manifold and carburetor as an assembly. Remove rocker arm and shaft assembly. Remove push rods and identify to insure installation in original location. Remove cylinder head bolts, cylinder head and gasket.

Installation – Coat gasket with suitable sealer. Install gasket and head on cylinder block. Install bolts and tighten in two steps to specifications. Use tightening sequence shown in illustration.

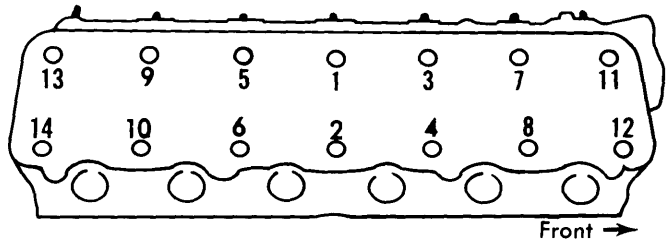

Fig. 1 Cylinder Head Tightening Sequence

VALVES

VALVE ARRANGEMENT

E-I-E-I-E-I-E-I-E-I-E

VALVE GUIDE SERVICING

Wear Check – Remove valve springs and install suitable sleeve (C-3973) over valve stem and install valve. Attach suitable dial indicator to cylinder head and set it at right angle to valve stem being measured. Total sideplay should not exceed .017". If dial reading is excessive or stems are scuffed or scored, ream guides for installation of valves with oversize stems.

Servicing – Ream guides to next oversize valve stem. Oversize valve stems are available in .005", .015" and .030" sizes.

NOTE – Do not attempt to ream guides from standard diameter to .030" oversize in one step. Use step procedure to obtain the .030".

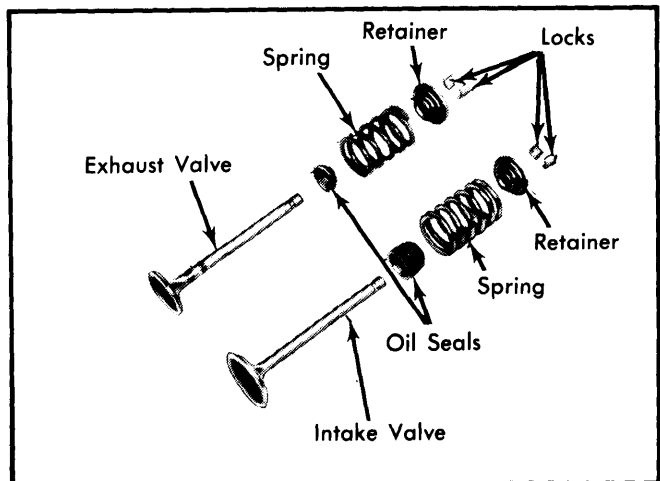

Fig. 2 Exploded View of Intake and Exhaust Valve Assembly

VALVE SPRINGS

Removal – With cylinder head removed, compress valve springs using suitable tool (C-3422A). Remove valve retaining locks, retainers and valve springs.

VALVE STEM OIL SEALS

Cup type used on all valves. Long seal used on intake valve and short seal used on exhaust valve.

225" 6 CYLINDER (Cont.)

Installation — Reverse removal procedure and only compress spring enough to install the locks. Check valve spring height.

VALVE SPRING INSTALLED HEIGHT

Valve springs must be square within $\frac{1}{16}$ ". Installed height of spring (measured from spring contact area on head to underside of spring retainer) should not exceed $1\frac{3}{64}$ ". If height is greater than maximum allowable, install $\frac{1}{16}$ " spacer(s) to bring height back to normal ($1\frac{5}{8}$ " to $1\frac{1}{16}$ ").

ROCKER ARM ASSEMBLY

See illustration for assembly of parts, noting the following: The assembly must be installed with oil hole upward and toward front of engine. Be sure that shaft retainers are seated on rocker shaft and not on extended bushing of rocker arm. Install long retainer at center position and special shaft bolt at rear of engine. Tighten bolts.

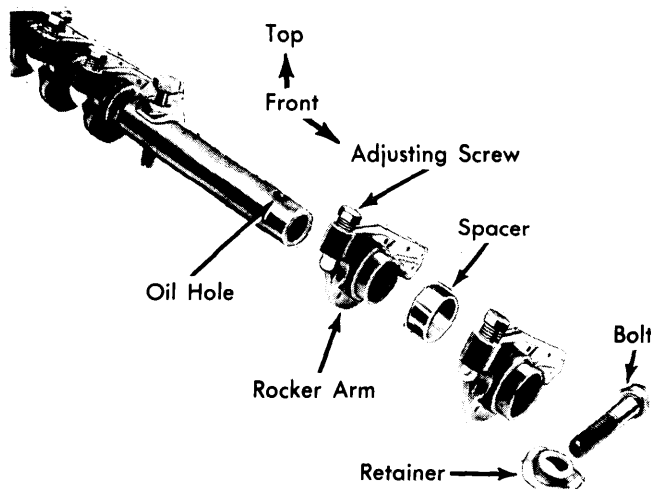

Fig. 3 Partially Disassembled View of Rocker Arm Shaft Assembly

MECHANICAL VALVE LIFTER ADJUSTMENT

Temporarily set intake to .012" and exhaust to .028" with engine cold. Operate engine until normal operating temperature is reached (approximately 195°F water temperature). Allow engine to idle at 550 RPM at operating temperature for five minutes. Adjust intake to .010" and exhaust to .020" with engine at operating temperature.

PISTONS, PINS & RINGS**OIL PAN**

See *Oil Pan Removal at end of ENGINE Section.*

PISTON & ROD ASSEMBLY

Removal — With cylinder head and oil pan removed, use a suitable ridge cutter (C-3012) to remove any ridge or deposits on upper end of cylinder bore. **NOTE** — Piston must be at bottom of stroke and covered with cloth to collect cutting. Inspect connecting rods and caps for cylinder identification and mark as necessary. Remove rod cap and push piston and rod assembly out top of cylinder block, taking care not to nick crankshaft journal or cylinder wall. Install rod caps on mating rods.

Installation — 1) Compression ring gaps must be located on piston so they will be on left side of engine and staggered about 60° apart. **NOTE** — Neither gap should line up with oil ring rail gaps. Rotate oil ring expander so gaps are at right side of engine and rotate steel rails so gaps are opposite (positioned above piston pin holes).

2) Lightly coat cylinder bores, pistons and rings with engine oil, slide suitable ring compressor C-385 (or equivalent) over piston and tighten. Install each piston and rod assembly (notch on piston head and oil hole in connecting rod facing toward front of engine) in its respective bore and guide connecting rod onto crankshaft journal. Tap piston head with hammer handle to seat connecting rod against crankshaft. Install rod caps, nuts and tighten.

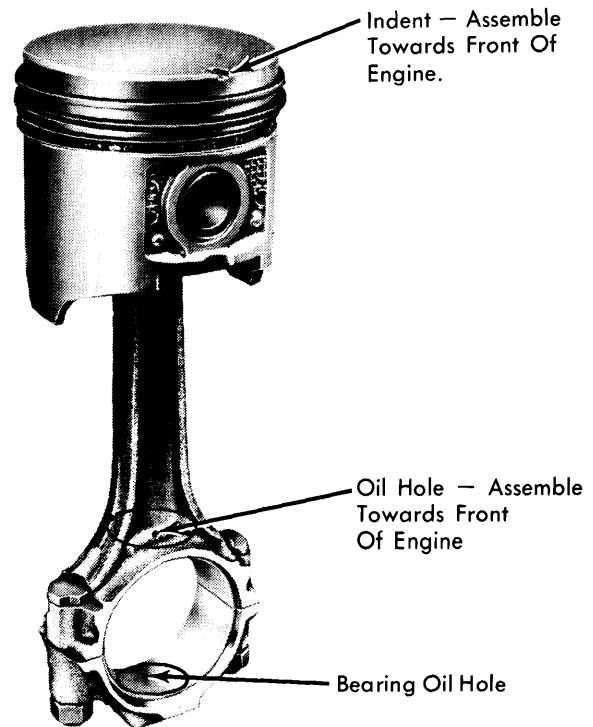

Fig. 4 Assemble Piston to Connecting Rod as Illustrated

FITTING PISTONS

With pistons and cylinder bores dry and clean, measure for piston-to-cylinder wall clearance (.005-.0015"). Measurements should be taken at room temperature (70°F). Measure piston diameter at top of skirt 90° to piston pin axis. Measure cylinder bore halfway down cylinder and 90° to crankshaft center line.

PISTON PINS

Removal — Use tool layout shown in Fig. 5 to press piston pin from bore.

Installation — Lubricate pin bore and use suitable tool (C-3724) and arbor press to install piston pin while noting following: Position piston head and connecting rod with notch and oil hole UP so oil hole will face front of engine upon installation. Press pin into position until pin bottoms on pilot tool.

225" 6 CYLINDER (Cont.)

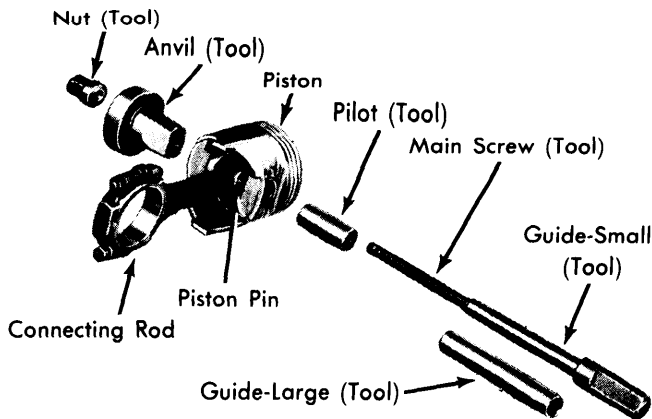

Fig. 5 Tool Arrangement for Piston Pin Removal

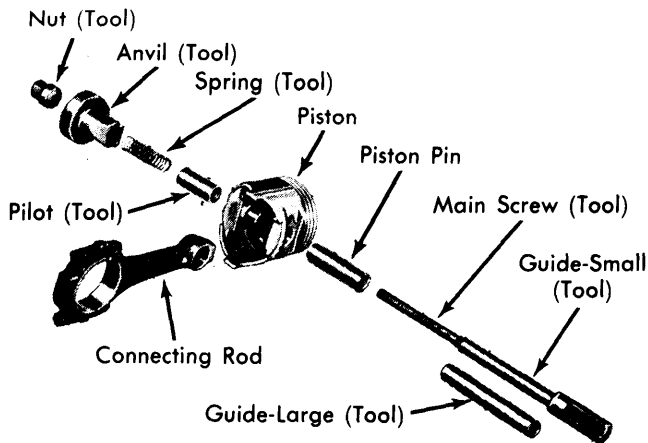

Fig. 6 Tool Arrangement for Installing Piston Pin

CRANKSHAFT & ROD BEARINGS

MAIN & CONNECTING ROD BEARINGS

NOTE — On engines manufactured after June 1, 1976, Engine may be equipped with either a cast or forged crankshaft. On engines equipped with automatic transmissions, the vibration damper and torque converter are interchangeable between the cast and forged crankshaft. On manual transmission equipped engines, the vibration dampers between cast and forged crankshafts are **NOT** interchangeable. The forged crankshaft engine requires that a crankshaft screw and washer be used and torqued to 135 ft. lbs.

Connecting Rod Bearings — 1) **NOTE** — Use either Shim Stock method or Plastigage method to check bearing clearance. After ensuring rod caps are marked for identification, remove rod caps. Using Shim Stock method, smooth edges of a $\frac{1}{2}$ " by $\frac{3}{4}$ " piece of brass shim stock .001" thick. Oil and place between bearing and connecting rod journal. Install bearing cap and tighten.

2) Rotate crankshaft $\frac{1}{4}$ turn in each direction. If a slight drag is felt, clearance is within limits. If no drag is felt, clearance is excessive. If crankshaft can not be rotated, clearance is not enough.

3) Using Plastigage method, insert a .001" to .003" (Green) piece of plastigage between bearing and connecting rod journal. Install bearing cap and tighten to correct torque specification.

4) Remove bearing cap and compare width of plastigage with scale on package. If plastigage width is within specifications, move on to next rod bearing. If it is not within specifications, the correct undersized bearings will have to be fitted.

5) New bearings are available in standard, .001", .002", .003", .010" and .012" undersize. Always install bearings in pairs. Do not use a new bearing with an old bearing. Install connecting rod bearings so formed tang fits into machined groove in connecting rod. Install rod caps and tighten nuts.

Main Bearings — 1) Using either Shim Stock method or Plastigage method, check main bearing clearances one at a time while all other main bearing caps are tight. New bearings are available in standard, .001", .002", .003", .010" and .012" undersize. A new .001" bearing half may be used in combination with a new standard bearing half or a .002" with a .001". **NOTE** — Always use smaller diameter bearing half as upper.

2) If bearing clearances are not within limits, remove bearing cap, insert suitable tool (C-3509) in oil hole journal and rotate crankshaft clockwise to remove upper bearing half. To install new upper bearing, lightly chamfer sharp edges from plain side and start bearing in place.

3) Insert tool and slowly rotate crankshaft counterclockwise, sliding bearing in place. Install main bearing cap with new bearing installed and tighten. **NOTE** — Upper main bearings are grooved and lower main bearings are plain. Upper and lower are not interchangeable.

4) Check crankshaft endplay and if it is not within the correct specifications, change number three main bearing. This bearing carries thrust load. Recheck crankshaft endplay.

REAR MAIN BEARING OIL SEAL

New split type rubber seals may be replaced without removing the crankshaft. New type seals must be installed as a pair and cannot be used or combined with old type rope seals.

Removal — Remove upper rope seal by turning suitable tool (C-4148) into end of seal and pulling seal out with tool, being careful not to mar crankshaft. Remove lower seal by carefully prying from the side with small screwdriver.

Installation — Oil upper seal lip lightly with engine oil. Hold seal (with paint stripe to rear) tightly against crankshaft with a thumb and rotate crankshaft while sliding seal into groove.

CAUTION — Sharp edge of groove in block may shave or nick the back of the seal. Care must be exercised not to damage the sealing lip. Install lower half of seal into lower seal retainer with paint stripe to the rear. Install main bearing cap and tighten. Install lower seal retainer and tighten. **NOTE** — Do not use sealer or cement on seal ends or lip.

225" 6 CYLINDER (Cont.)

CAMSHAFT

ENGINE FRONT COVER

Removal — Drain cooling system and remove radiator and fan. Use suitable puller (C-3732A) and remove vibration damper. Loosen oil pan bolts to provide clearance between pan and lower flange of cover. Remove cover bolts and cover.

Installation — Check that mating surfaces of chain case cover and cylinder block are clean and free from burrs. Install cover with new gasket and tighten bolts. Tighten oil pan bolts with gaskets in place. Install vibration damper, radiator and fan. Fill cooling system.

FRONT COVER OIL SEAL

Removal — With front cover removed, use a suitable tool behind the lip of the oil seal to pry outward, being careful not to damage crankshaft seal surface of cover.

Installation — Install new seal by installing the threaded shaft part of tool (C-4251) into threads of crankshaft. Place seal into opening with seal spring towards the inside of engine. Place installing adapter (C-4251-2) with the thrust bearing and nut on the shaft. Tighten nut until tool is flush with the timing chain cover.

TIMING CHAIN

Checking For Stretch — Place scale next to timing chain to measure any movement of the chain. Place torque wrench with socket over camshaft sprocket lock bolt and apply torque in direction of crankshaft rotation to take up slack. Torque should be 30 ft. lbs. with heads installed or 15 ft. lbs. with heads removed. Apply torque in reverse direction and measure amount of chain movement. If movement exceeds $\frac{1}{8}$ " , replace chain.

Removal & Installation — Remove camshaft sprocket attaching bolt and remove timing chain with camshaft sprocket. Turn crankshaft to line up centerline of camshaft and crankshaft with the timing mark on crankshaft sprocket. Install camshaft sprocket and timing chain. Line up timing marks on sprockets with centerline of crankshaft and camshaft. Tighten camshaft sprocket bolt.

CAMSHAFT

Removal — Remove tappets using suitable tool (C-4129). Remove timing chain sprockets, distributor, oil pump and fuel pump. Install a long bolt in front end of camshaft to facilitate careful removal. Remove camshaft, being careful not to damage cam bearings with the cam lobes.

Installation — Lubricate camshaft lobes and bearing journals. Carefully install camshaft in cylinder block. Install all components removed prior to camshaft removal.

CAMSHAFT BEARINGS

Removal — With camshaft removed, drive out rear cam bearing welch plug. Install proper size adaptors and horseshoe washers (C-3132A) at the back of each bearing and drive out all bearings.

Installation — Install new bearings using suitable tool by sliding new bearing over the proper adaptor. Position bearing on tool. Install horseshoe lock and drive the bearing into place.

NOTE — Camshaft bearing oil hole or holes must be in exact alignment with drilled oil passages from main bearings. Install number one camshaft bearing $\frac{3}{32}$ " inward from front face of cylinder block. Apply sealer to new welch plug and install at rear of camshaft. Be sure this plug does not leak.

VALVE TIMING

1) Turn crankshaft until No. 6 exhaust valve is closing and No. 6 intake is opening.

2) Turn No. 1 intake valve adjusting screw in one turn to remove lash. Install dial indicator so plunger contacts valve spring retainer at a 90° angle. Zero indicator.

3) Turn crankshaft clockwise until intake valve has lifted .029". Timing indicator on front pulley should read between 12° BTDC and TDC.

4) If front pulley marks are not within limits, inspect sprocket index marks, timing chain for wear or check accuracy of TDC mark on front pulley.

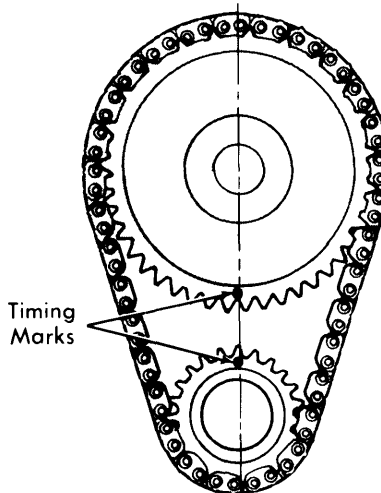

Fig. 7 Timing Chain and Crankshaft Sprocket Alignment

ENGINE OILING

Crankcase Capacity — 4 quarts. Add 1 quart with filter change.

Oil Filter — Replace every second oil change. Follow installation directions printed on case of new filter.

Normal Oil Pressure — 30-70 psi at 2000 RPM.

Pressure Regulator Valve — In oil pump body. Not adjustable.

ENGINE OILING SYSTEM

Refer to Fig. 8 and note the following:

Rocker Arms & Valves — Transverse channel in rear camshaft journal feeds oil from rear camshaft bearing up through channel in block and cylinder head to rear rocker arm shaft bracket (oil flows around rear bracket bolt into rocker shaft). Trough on upper surface of rocker arm lubricates pushrod seats and valve stems.

Crankshaft Bearings — All main bearings are lubricated as shown in Fig. 8. Connecting rod bearings are lubricated by holes drilled in crankshaft between main and rod journals.

225" 6 CYLINDER (Cont.)

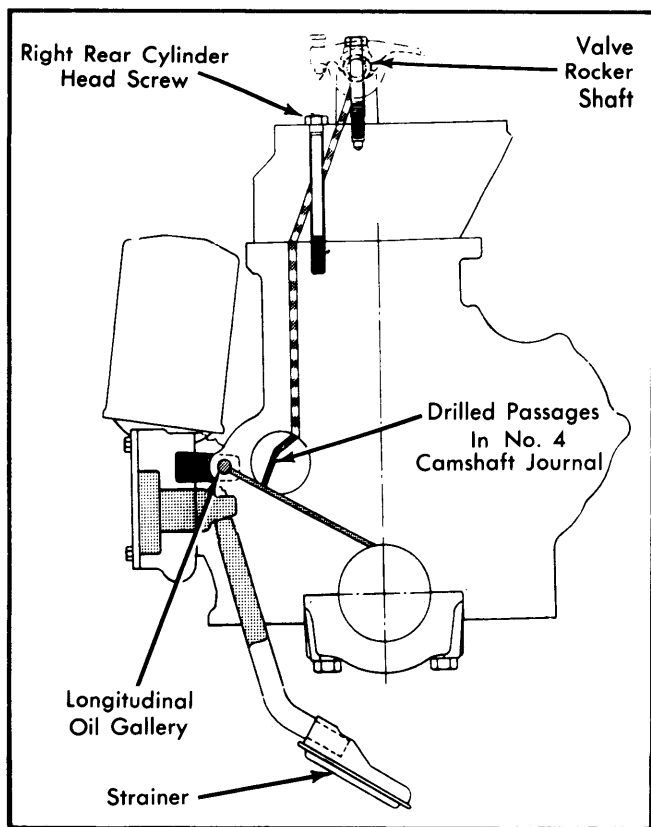

Fig. 8 Diagram of Engine Oiling Circuit

OIL PUMP

Disassembly — Remove pump cover and seal ring. Press off drive gear while supporting gear to eliminate load on aluminum body of pump. Remove outer rotor and inner rotor with shaft. Remove oil pressure relief valve plug, spring and valve.

Inspection — Clean and inspect all parts for damage. Measure all clearances indicated in Oil Pump Specifications table and replace as follows:

- 1) Replace entire pump assembly if pump cover wear, clearance over rotors or outer rotor-to-pump body clearance are not within specifications.
- 2) Replace both rotor assemblies if tip clearance between rotors, rotor thickness or rotor diameter are not within specifications.
- 3) Oil pressure relief valve must be free from scoring and operate freely in bore of pump body. Spring should have a free length of 2 ¼" and test between 22.3 and 23.3 lbs. when compressed to 1 1/32". Replace spring which does not meet specifications.

Assembly & Installation — Assemble pump in reverse order of disassembly using new parts as necessary. Prime oil pump before installation by filling rotor cavity with engine oil. Install pump on engine.

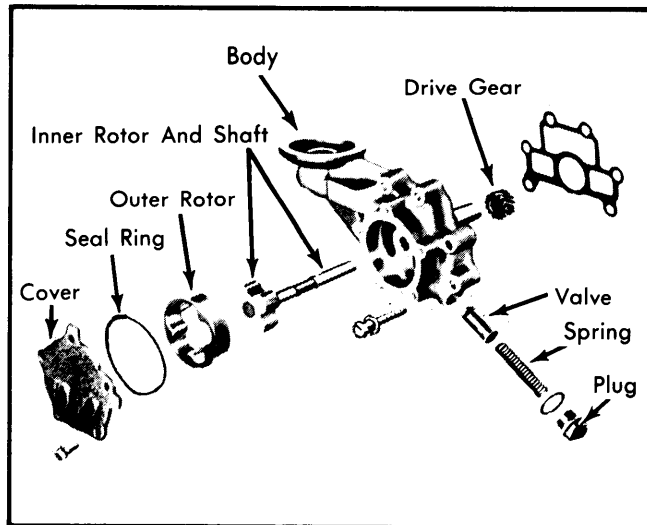

Fig. 9 Exploded View of Oil Pump Assembly

Oil Pump Specifications

Application	Specification
Pump Cover Wear.....	.0015" Max.
Inner & Outer Rotor Thickness.....	.649" Min.
Outer Rotor Diameter.....	2.469" Min.
Clearance Over Rotors.....	.004" Max.
Outer Rotor-to-Pump Body Clearance.....	.014" Max.
Tip Clearance Between Rotors.....	.010" Max.

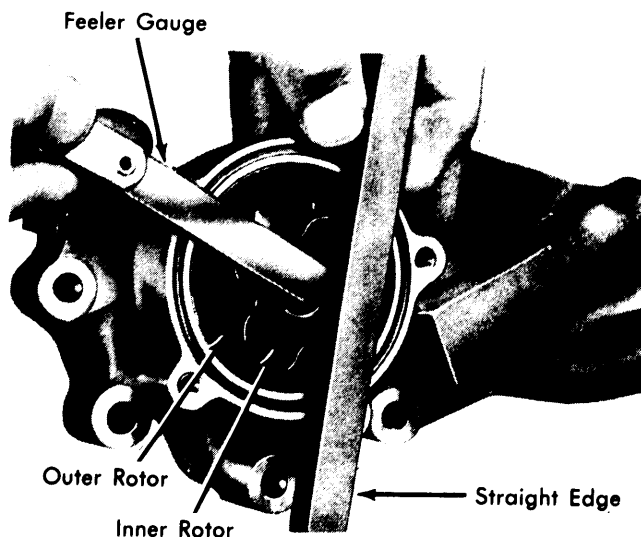

Fig. 10 Making Rotor Clearance Measurement with Feeler Gauge and Straightedge

Chrysler Corp. 6 Engines

225" 6 CYLINDER (Cont.)

ENGINE SPECIFICATIONS

GENERAL SPECIFICATIONS						
Engine	Net HP At RPM	Torque (Ft. Lbs. at RPM)	Compr. Ratio	Bore	Stroke	Displ. Cu. Ins.
225" 1-Bbl.	100@3600	170@1600	8.4-1	3.40"	4.12"	225
225" 2-Bbl.	110@3600	180@2000	8.4-1	3.40"	4.12"	225

VALVES							
Engine & Valve	Head Diam.	Face Angle	Seat Angle	Seat Width	Stem Diameter	Stem Clearance	Valve Lift
225" Int.	1.620"	43°	45°	.070-.090"	.372-.373"	.001-.003"	.406"
Exh.	1.360"	43°	45°	.040-.060"	.371-.372"	.002-.004"	.414"

VALVE SPRINGS			
Engine	Free Length	PRESSURE (LBS.)	
		Valve Closed	Valve Open
225"	1.92"	49-57 @ 1 1/16"	137-150 @ 1 5/16"

VALVE TIMING				
Engine	INTAKE		EXHAUST	
	Open (BTDC)	Close (ABDC)	Open (BBDC)	Close (ATDC)
225"	16°	48°	54°	10°

PISTONS, PINS, RINGS						
Engine	PISTONS Clearance	PINS		RINGS		
		Piston Fit	Rod Fit	Rings	End Gap	Side Clearance
225"	.0005-.0025"	.00035-.00085"	⊙.0007-.0017"	1	.010-.020"	.0015-.003"
				2	.010-.020"	.0015-.003"
				3	.015-.055"	.0002-.005"

⊙ — Interference fit.

CRANKSHAFT MAIN & CONNECTING ROD BEARINGS							
Engine	MAIN BEARINGS				CONNECTING ROD BEARINGS		
	Journal Diam.	Clearance	Thrust Bearing	Crankshaft End Play	Journal Diam.	Clearance	Side Play
225"	2.7495-2.7505"	.0005-.002"	No.3	.002-.009"	2.1865-2.1875"	.0005-.0025"	.006-.025"

225" 6 CYLINDER (Cont.)
ENGINE SPECIFICATIONS (Cont.)

CAMSHAFT			
Engine	Journal Diam.	Clearance	Lobe Lift
225"			
No.1	1.998-1.999"	.001-.003"
No.2	1.982-1.983"		
No.3	1.967-1.968"		
No.4	1.951-1.952"		

TIGHTENING SPECIFICATIONS	
Application	Ft. Lbs.
Cylinder Head	70
Manifold-to-Cylinder Head	10
Intake-to-Exhaust Manifold	①17
Oil Pan	17
Main Bearing Cap	85
Rear Main Bearing Seal Retainer	30
Connecting Rod Cap	45
Camshaft Sprocket	50
Rocker Shaft Support Bracket	24
Rocker Arm Cover	3
Oil Pump Cover	8
Engine Front Cover	17
Oil Pump Attaching Bolt	17
Water Pump	30
Oil Filter Stud	10
Front Mount-to-Frame	75
Front Mount-to-Engine	50

① — Tighten 3/8" Bolt to 20 Ft Lbs.