

232" & 258" 6-CYL.

IDENTIFICATION CODING

ENGINE IDENTIFICATION

Engine number is located on machined pad on cylinder block between number two and three cylinders. Letter contained in code number identifies engine by CID, carburetor type and compression ratio.

Code	CID	Carb.	Comp. Ratio
A	258	1-Bbl.	8.0-1
C	258	2-Bbl.	8.0-1
E	232	1-Bbl.	8.0-1

SPECIAL ENGINE MARKS

Some engines are produced with oversize or undersize components. These engines are identified by a letter code stamped on boss between ignition coil and distributor. Letters are decoded as follows:

- B - All cylinder bores .010" oversize.
- C - All camshaft bearing bores .010" oversize.
- M - All main bearing journals .010" undersize.
- P - All connecting rod journals .010" undersize.

ENGINE REMOVAL

See Engine Removal at end of ENGINE Section.

CYLINDER HEAD & MANIFOLDS

INTAKE & EXHAUST MANIFOLDS

Removal - 1) Remove air cleaner and carburetor. Disconnect accelerator cable from accelerator bellcrank. Disconnect PCV vacuum hose from intake manifold.

2) Remove spark CTO vacuum tubes and disconnect TCS solenoid vacuum valve wiring (if equipped). Take off Air Guard hoses at air pump and air injection manifold check valve.

3) Disconnect diverter valve with hoses if equipped. Remove air pump/power steering bracket, air pump and detach and set aside power steering pump if so equipped.

4) If equipped with air conditioning, remove drive belt idler assembly from cylinder head. Take off exhaust back pressure sensor and EGR valve.

5) Disconnect exhaust pipe from manifold flange and remove all attaching bolts, nuts and clamps and remove intake and exhaust manifold as an assembly. Separate manifolds at riser area.

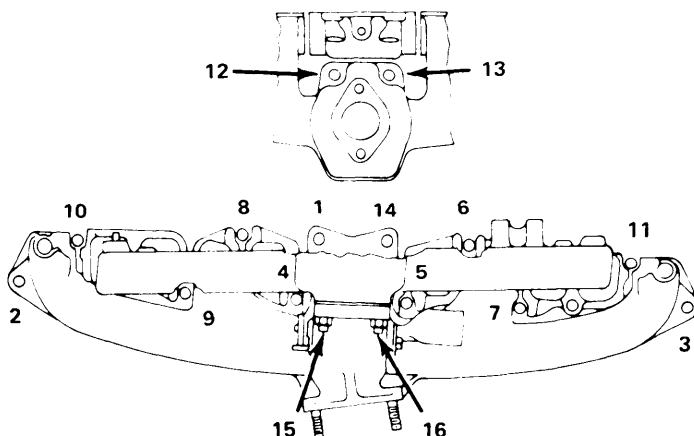

Fig. 1 Intake Manifold Tightening Sequence

Installation - 1) Clean all mating surfaces of manifold and cylinder head. Assemble manifolds and finger tighten heat riser retaining nuts.

2) Position new intake manifold gasket on cylinder head and install manifold assembly. Tighten manifold attaching bolts and nuts in sequence (see Fig. 1). To complete assembly, reverse removal procedure.

CYLINDER HEAD

Removal - 1) Drain cooling system and disconnect hoses at thermostat housing. Remove rocker arm cover, rocker arms and bridged pivot assembly (back off each screw one turn at a time to avoid breaking bridge).

2) Remove push rods. **NOTE** - Retain push rods, bridged pivots and rocker arms in same order as removed. Take off intake and exhaust manifold assembly.

3) If equipped with air conditioning, remove drive belt idler bracket from cylinder head. Loosen alternator drive belt, remove bolts from air compressor mounting bracket and set compressor aside. Remove spark plugs.

4) Take off temperature sending unit wire and battery ground cable. Remove ignition coil and bracket assembly, remove cylinder head bolts and lift off cylinder head.

Installation - 1) Clean and inspect all parts thoroughly. Transfer all attached components from original head not included with replacement head.

2) Clean block and cylinder head surfaces carefully, apply even coat of sealing compound to both sides of new head gasket and position on block assembly with word "TOP" facing upward.

3) Install cylinder head and tighten head bolts in sequence. (see Fig. 2). Reverse removal procedure to replace all remaining components.

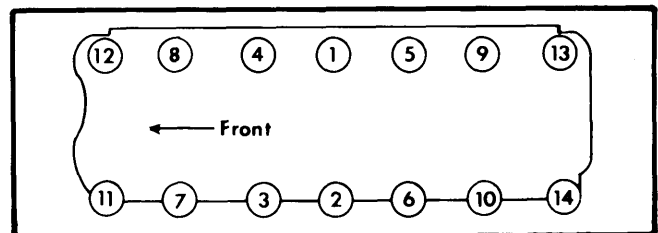

Fig. 2 Cylinder Head Tightening Sequence

VALVES

VALVE ARRANGEMENT

E-I-I-E-I-E-I-E-I-E-I-E-I-E (front to rear).

VALVE GUIDE SERVICING

Valve guides are integral with cylinder head. If valve stem-to-guide clearance is not within specifications, ream guide to install valve with oversize stem. Valves are available in .003", .015" and .030" oversize. **CAUTION** - Ream valve guides in steps, starting with .003" reamer and progressing to size required.

232" & 258" 6-CYL. (Cont.)

VALVE STEM OIL SEALS

Nylon oil deflectors are used on all valves. These oil deflectors should always be replaced whenever valve service is performed.

VALVE SPRINGS

Removal, Cylinder Head Installed — 1) Remove rocker arm cover, rocker arms and bridged pivot assemblies. Remove push rods and spark plug of cylinder to be worked on.

2) Install suitable air line adapter to spark plug hole and apply air pressure to hold valve in place.

3) Use spring compressor and collapse valve spring enough to remove locks. Remove spring and retainer.

Installation — 1) Install valve spring and retainer. Using same tools used for removal, compress valve spring, insert valve locks and release spring tension.

2) Tap spring from side to side to insure that spring is properly seated. Reverse removal procedure to complete installation.

ROCKER ARM ASSEMBLY

Rocker arm assemblies consist of stamped rocker arms, bridged pivot assembly and rocker arm cap screws. When removing or installing bridged pivot, loosen or tighten rocker arm cap screws only one turn at a time to avoid breaking bridge.

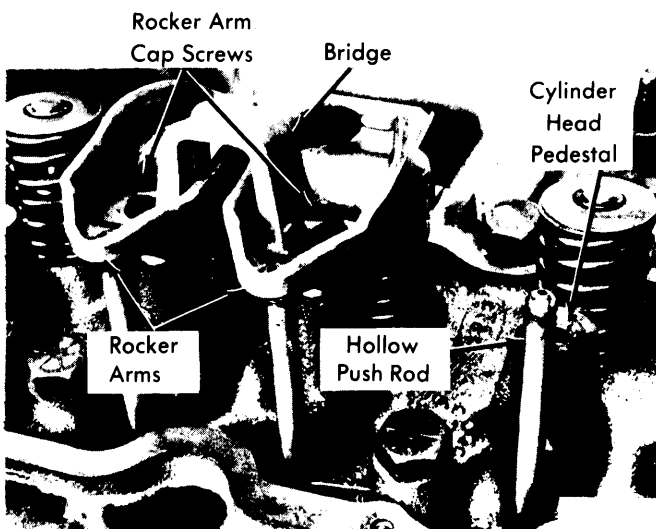

Fig. 3 Installed View of Bridged Pivot Assembly

HYDRAULIC LIFTER ASSEMBLY

Lifters are serviced as complete assemblies only and parts are not interchangeable between lifters. Inspect for signs of scuffing on barrel and face of lifter body. Inspect lifter face for signs of concave wear and if present, replace camshaft and lifters. If lifters are disassembled for cleaning and inspection, after reassembly (see Fig. 4), they should be tested using leak-down tester according to manufacturer's instructions. Discard lifters not within specifications. **NOTE** — Do not fill lifter assemblies with engine oil prior to installation as they will charge themselves with 3 to 8 minutes of engine operation.

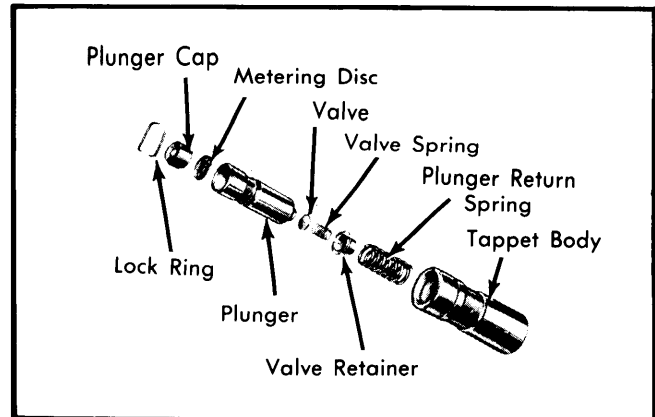

Fig. 4 Exploded View of Hydraulic Lifter Assembly

PISTONS, PINS & RINGS

OIL PAN

See Oil Pan Removal at end of ENGINE Section.

PISTON & ROD ASSEMBLY

NOTE — New pistons must be installed in same cylinders for which they were fitted, and used pistons in same cylinder from which they were removed.

Removal — 1) With cylinder head and oil pan removed, use a ridge reamer to remove any ridge or deposits on upper end of cylinder bore. **NOTE** — Piston must be at bottom of stroke and covered with cloth to collect cuttings.

2) Remove connecting rod bearing caps and retain in same order as removed. **NOTE** — Caps and rods are stamped with corresponding cylinder number. Install rubber hose over connecting rod studs to protect cylinder walls and push piston and rod assembly out of cylinder block.

Installation — 1) Position piston rings as follows: Oil control ring spacer expander gap on centerline within 20° of either skirt face. Oil control ring gaps 90° from expander gap and 30° apart. No. 2 compression ring gap 180° from top oil ring gap. No. 1 compression ring 180° from No. 2 ring gap. Upper and lower compression ring markings indicate top side of ring.

2) Lightly coat pistons, rings and cylinder walls with engine oil. Install suitable ring compressor on pistons ensuring that ring gap positions do not change. With connecting rod studs covered for cylinder wall protection, install each piston and rod assembly ensuring that notch on piston dome faces front of engine and that each piston is fitted to appropriate bore. **NOTE** — Oil holes in connecting rods must face toward camshaft.

3) Guide connecting rod onto crankshaft journal while tapping down on piston using suitable tool. Carefully seat connecting rod against crankshaft and install mating rod cap. Tighten connecting rod nuts to specified torque.

FITTING PISTONS

Measure cylinder bore diameter 2 5/16" below top of cylinder bore. Measure piston at right angles to piston pin at centerline of pin.

232" & 258" 6-CYL. (Cont.)

PISTON PINS

Removal — Place piston on suitable support and using suitable tool (J-21872) press pin from piston and rod with arbor press. Note position of pin through gauge window of remover support.

Installation — Using suitable pilot, driver and support (J-21872) press piston pin through connecting rod and piston until pin pilot indexes with mark on support. Pin should be centered in rod plus or minus $\frac{1}{32}$ ". **NOTE** — Never reuse a piston pin once it has been removed from piston and rod assembly. If little effort is required to install new piston pin in connecting rod, or if rod moves along pin, a new connecting rod is required. Check piston for freedom of movement on pin.

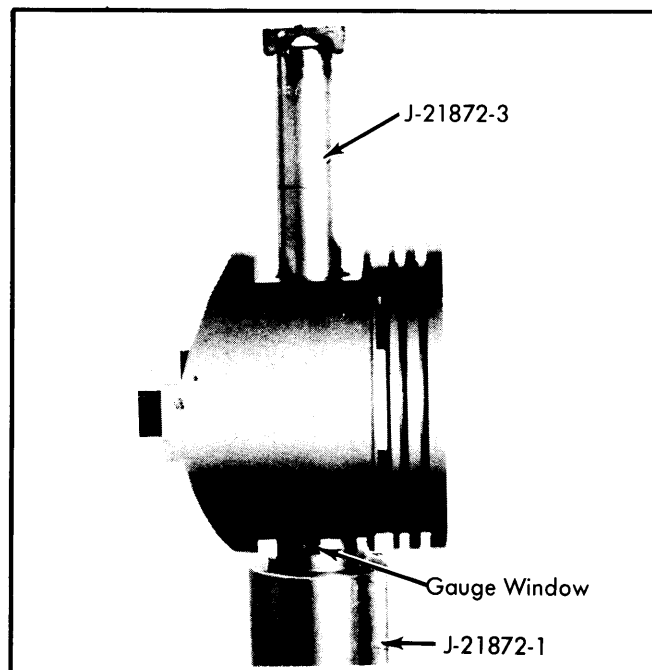

Fig. 5 Removing and Installing Piston Pin Using Special Tools Shown

CRANKSHAFT & ROD BEARINGS

MAIN & CONNECTING ROD BEARINGS

Connecting Rod Bearings — After ensuring rod caps are marked for cylinder identification, remove rod caps. Use Plastigage method to check for proper bearing clearances. If not within specifications, new bearings must be installed. New bearings are available in .001", .002", .010" and .012" undersize. Selective fitting is required on each connecting rod. A standard bearing may be used in combination with a .001" undersize or a .002" undersize in combination with a .001" undersize. **NOTE** — Never use a new bearing with a used bearing. Never use a pair of bearings with more than .001" difference in size on same journal. Coat bearing surfaces with oil, install rod cap and tighten nuts.

Main Bearings — 1) Support crankshaft at counterweight adjacent to main bearing being checked and ensure that all bearing caps other than one being checked are tight. Starting with rear main bearing cap and working forward, remove one cap at a time and check bearing clearances using Plastigage method.

2) If clearances are not within specifications, bearings are available in .001", .002", .010" and .012" undersize. A standard bearing may be used in combination with a .001" undersize or a .002" undersize in combination with a .001" undersize. **NOTE** — Never use a new bearing with a used bearing. Never use a pair of bearings with more than .001" difference in size on same journal.

3) Remove all upper bearings by inserting suitable tool in oil hole of crankshaft journal and rotating crankshaft clockwise to roll bearing from engine. Oil new bearing and rotate crankshaft so bearing will rotate in direction of its locating tang. Install bearing cap with lower bearing and tighten bolts.

THRUST BEARING ALIGNMENT

When replacing thrust bearings (located at No. 3 main bearing journal), crankshaft should be moved fore and aft to align thrust faces of bearings.

REAR MAIN BEARING OIL SEAL

Removal — Remove oil pan and rear main bearing cap. Loosen all remaining main bearing bolts. Using a brass drift, tap upper seal until seal is protruding enough to permit pulling it out completely. Remove lower seal from bearing cap.

Installation — Reverse removal procedure while noting following: Lip of seal must face toward front of engine. Ensure seal is firmly seated in bearing cap recess. Use suitable sealer and apply as indicated in illustration.

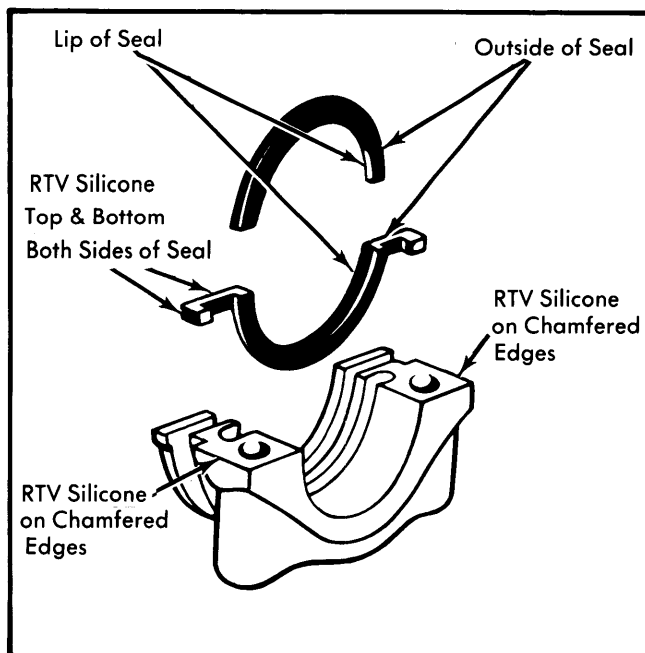

Fig. 6 Rear Main Oil Seal Installation Instructions (Note Where RTV Silicone Should be Applied)

CAMSHAFT

ENGINE FRONT COVER

Removal — 1) Remove drive belt(s), fan and hub assembly, accessory pulley (if equipped) and vibration damper. Remove oil pan-to-timing chain cover screws and cover-to-block screws.

232" & 258" 6-CYL. (Cont.)

2) Raise cover enough to detach retaining tips of oil pan seal from bottom side of cover. Remove cover and gasket from engine. Cut off oil pan seal end tabs flush with front face of cylinder block and remove seal.

Installation – 1) Clean all gasket mounting surfaces. Apply suitable sealing compound to both sides of cover gasket and position on cylinder block.

2) Cut end tabs of a new oil pan seal as described under removal and position seal on cover after using suitable sealer on seal end tabs. Position engine front cover on cylinder block.

3) Use proper tool to align front cover and install cover-to-block screws and oil pan-to-cover screws. Tighten all screws. Remove alignment tool and install vibration damper, pulley, fan and hub assembly and drive belt(s).

FRONT COVER OIL SEAL

Removal & Installation – Remove drive belt(s), accessory drive pulley and vibration damper. Remove oil seal using suitable tool (J-9256) or equivalent. To install new seal, apply light film of proper sealer on outside diameter of seal and position on cover with seal lip facing outward. Use suitable tools (J-9163 & J-22248) or equivalent to press seal into cover until it bottoms. Apply light film of engine oil on seal lip and install vibration damper, accessory drive pulley and drive belt(s).

TIMING CHAIN

Removal – Remove engine front cover. Remove camshaft sprocket retaining bolt and washer. Rotate crankshaft until timing mark on sprocket is aligned with camshaft sprocket timing mark. See Fig. 7. Remove sprockets and timing chain as an assembly.

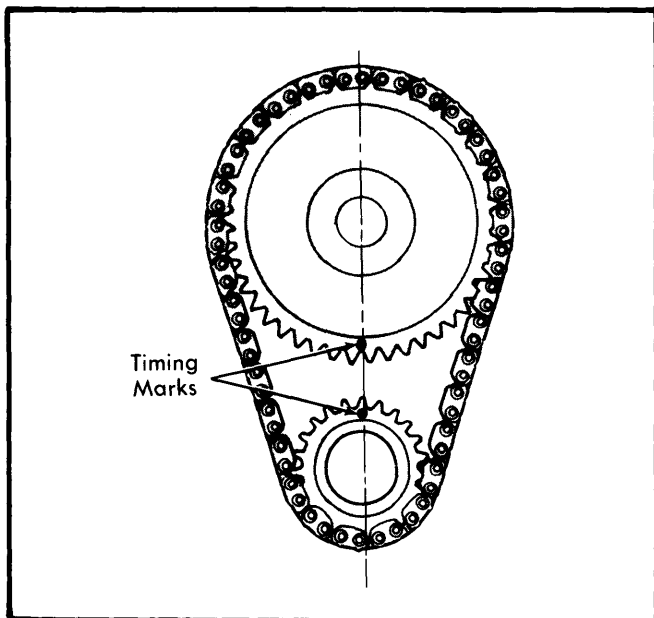

Fig. 7 Timing Chain Sprocket Alignment

Installation – Assemble timing chain, crankshaft sprocket and camshaft sprocket with timing marks aligned (see il-

lustration). Install assembly to crankshaft and camshaft. Install camshaft sprocket retaining bolt and washer, then tighten.

NOTE – If the timing chain deflects more than 1/2 inch it should be replaced.

CAMSHAFT

Removal – 1) Drain cooling system and remove radiator. Remove hood (Pacer only). Lift off air conditioning condenser and receiver assembly as a charged unit (if equipped). Remove rocker arm cover and valve assembly components.

2) Lift off cylinder head and remove hydraulic lifters. Remove drive belt(s), fan and hub assembly, damper drive pulley (if equipped). Remove timing case cover and fuel pump, and distributor with wiring.

3) Rotate crankshaft until 0° timing mark on crankshaft is closest to and in centerline with timing pointer of camshaft sprocket. Remove crankshaft sprocket, camshaft sprocket and timing chain as an assembly.

4) On Pacer only, support front of engine with lifting device and disconnect front support cushions from crossmember. Lift engine enough to allow camshaft removal. On all other models, remove bumper and grille as required and remove camshaft.

Installation – Reverse removal procedure while noting following: Lubricate camshaft with suitable oil supplement and install camshaft carefully to avoid damage to camshaft lobes.

CAMSHAFT BEARINGS

Removal & Installation – With camshaft removed, remove bearings using suitable bearing remover. Bearing bores are step-bored (largest at front, smallest at rear). Install bearings using suitable bearing installer and install camshaft.

CAM LOBE LIFT

Remove rocker arm cover, rocker arm assembly and spark plugs. Proceed as follows:

1) Using suitable clamping or mounting fixture, attach dial indicator to cylinder head so indicator probe rests on top of push rod with indicator and probe in a vertical position over push rod.

2) Rotate crankshaft slowly until valve lifter is on heel of cam lobe. At this point, push rod will be at its lowest point.
CAUTION – If using an auxiliary starter switch, distributor primary lead must be disconnected from negative post of coil.

3) With push rod at lowest position, zero dial indicator and rotate engine until push rod is in fully raised position. Compare total lift recorded with specifications. If less than specifications, camshaft is defective. Check all remaining lobes of camshaft in same manner.

VALVE TIMING

Remove spark plugs and rocker arm cover. Rotate crankshaft until No. 6 piston is at TDC on compression stroke. Rotate crankshaft counterclockwise 90°. Install dial indicator with indicator point touching No. 1 cylinder intake rocker arm at push rod end and set dial indicator to zero. Rotate crankshaft

232" & 258" 6-CYL. (Cont.)

clockwise until dial indicator shows .016" lift. Timing mark on vibration damper should index with TDC mark on engine front cover. If timing mark is more than 1/2" off TDC in either direction, valve timing is incorrect.

ENGINE OILING

Crankcase Capacity — 4 quarts. Add 1 quart with filter change.

Oil Filter — Replace every 7,500 miles or 7 months, whichever comes first.

Normal Oil Pressure — 13 psi minimum at 600 RPM and 37-75 psi maximum at 1600+ RPM.

Pressure Regulator Valve — Located in pump body. Not adjustable.

ENGINE OILING SYSTEM

Oil under pressure is directed from oil pump to a full-flow oil filter. In case filter becomes clogged and restricts full flow of oil, a by-pass valve is located in filter mounting base. From oil filter, oil flow is directed as follows:

Crankshaft & Camshaft Bearings — Main and camshaft bearings receive oil from main oil gallery. From main bearings oil passes through passage in crankshaft to connecting rod bearings. Oil throw-off from each connecting rod bearing lubricates cylinder walls, piston pins, camshaft lobes and distributor drive gear.

Hydraulic Valve Tappets — Lubricated directly from main oil gallery.

Timing Chain & Sprockets — Oil is received from front camshaft bearing and returns to crankcase through cavity under front main bearing cap.

Rocker Arms & Bridged Pivot Assemblies — Oil is supplied to rocker arms from hydraulic valve lifters through hollow push rods to rocker arm assemblies. Oil from rocker arms lubricate valve train components, then passes down through push rod guides and into oil pan.

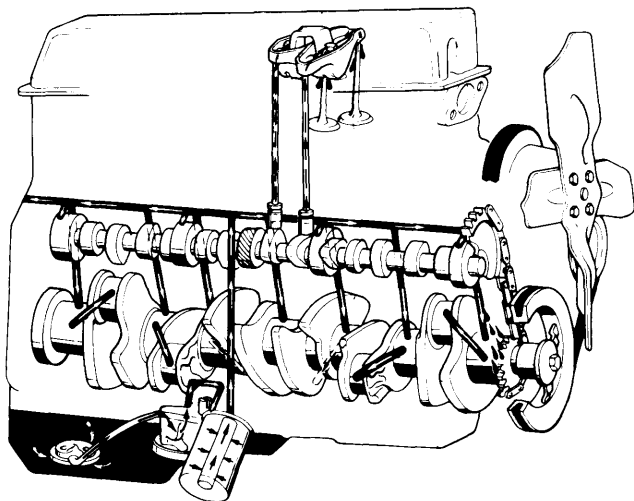

Fig. 8 Engine Oil Circuit Diagram

OIL PUMP

Oil pump is driven by distributor drive shaft. Removal of oil pump will not affect ignition timing, as distributor gear remains meshed with camshaft gear. Remove pump cover and gasket. Measure end clearance of pump gears. Place suitable straightedge across gears and pump body. Pass feeler gauge between straightedge and gears. Correct clearance is .004-.008" with .007" preferred. Oil pump gear-to-body clearance should be .0005-.0025" with .0005" desired. Measure between gears and wall of cavity opposite point of gear mesh. Pump must be filled with petroleum jelly or equivalent prior to installation of oil pump cover.

CAUTION — Oil inlet tube position must be changed to allow removal of relief valve. Pickup tube assembly must be replaced at installation using suitable sealer.

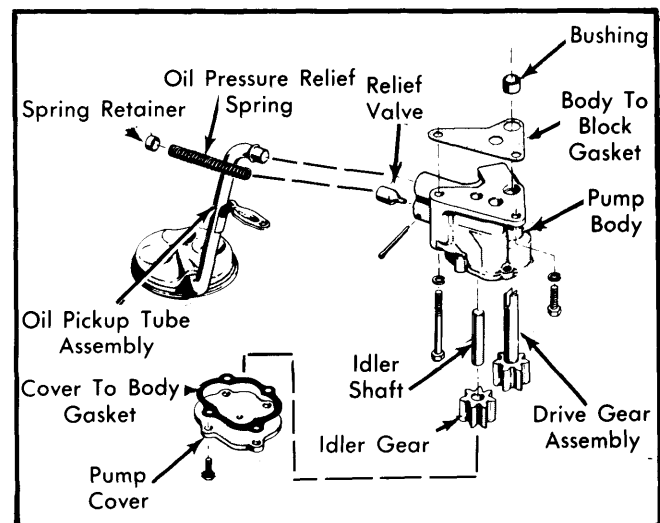

Fig. 9 Exploded View of Oil Pump Assembly

TIGHTENING SPECIFICATIONS

Application	Ft. Lbs.
Camshaft Sprocket	50
Clutch Housing-to-Block	
Top	27
Bottom	43
Connecting Rod Nuts	33
Cylinder Head	105
Drive Plate-to-Converter	22
Engine Front Cover	5
Exhaust Manifold	23
Flywheel-to-Crankshaft	105
Fuel Pump	16
Intake Manifold	23
Main Bearing Caps	80
Oil Pan	
1/4"	7
5/16"	11
Oil Pump Cover	6
Oil Pump Screw	
Short	10
Long	17
Thermostat Housing	13
Vibration Damper	(Lubricated) 80
Water Pump	13

American Motors 6 Engines

232" & 258" 6-CYL. (Cont.)

ENGINE SPECIFICATIONS

GENERAL SPECIFICATIONS						
Engine	Net HP At RPM	Torque (Ft. Lbs. at RPM)	Compr. Ratio	Bore	Stroke	Displ. Cu. Ins.
232" 1-Bbl.	90@3400	168@1600	8.0-1	3.75"	3.50"	232
258" 1-Bbl.	100@3400	200@1600	8.0-1	3.75"	3.895"	258
258" 2-Bbl.	120@3600	201@1800	8.0-1	3.75"	3.895"	258

VALVES							
Engine & Valve	Head Diam.	Face Angle	Seat Angle	Seat Width	Stem Diameter	Stem Clearance	Valve Lift
All Engines Int.	1.787"	29°	30°	.040-.060"	.3715-.3725"	.001-.003"
Exh.	1.406"	44°	44°	.040-.060"	.3715-.3725"	.001-.003"

VALVE SPRINGS			
Engine	Free Length	PRESSURE (LBS.)	
		Valve Closed	Valve Open
All Engines	1.99"	64-72@ $1\frac{25}{32}$ "	188-202@ $1\frac{13}{32}$ "

VALVE TIMING				
Engine	INTAKE		EXHAUST	
	Open (BTDC)	Close (ALDC)	Open (BLDC)	Close (ATDC)
232" & 258" 1-Bbl.	12°	65°	53°	24°
258" 2-Bbl.	15°	69°	56°	28°

PISTONS, PINS, RINGS						
Engine	PISTONS	PINS		RINGS		
	Clearance	Piston Fit	Rod Fit	Rings	End Gap	Side Clearance
All Engines	.0009-.0017"	.0003-.0005"	Press Fit	1 2 3	.010-.020" .010-.020" .010-.025"	.0015-.003" .0015-.003" .001-.008"

CRANKSHAFT MAIN & CONNECTING ROD BEARINGS							
Engine	MAIN BEARINGS				CONNECTING ROD BEARINGS		
	Journal Diam.	Clearance	Thrust Bearing	Crankshaft End Play	Journal Diam.	Clearance	Side Play
All Engines	2.4994"	.001-.003"	3	.0015-.0065"	2.0944"	.001-.003"	.005-.014"

CAMSHAFT			
Engine	Journal Diam.	Clearance	Lobe Lift
No. 1	2.029-2.030"	.001-.003"	① .232"
No. 2	2.019-2.020"		② .248"
No. 3	2.009-2.010"		
No. 4	1.999-2.000"		

- ① — 232" & 258" engines w/1-Bbl. Carburetor.
 ② — 258" engine w/2-Bbl. Carburetor.