

121" 4-CYL.

IDENTIFICATION CODING

ENGINE IDENTIFICATION

Engine number is located on machined flange at left rear of block adjacent to oil level indicator. Letter contained in code number identifies engine by CID, carburetor type and compression ratio.

Application	Code
121" 2-Bbl.	G

SPECIAL ENGINE MARKS

Oversize or undersize components are not used in this engine.

ENGINE REMOVAL

See *Engine Removal at end of ENGINE Section.*

CYLINDER HEAD & MANIFOLDS

INTAKE MANIFOLD

Removal – 1) Drain cooling system. Remove air cleaner and disconnect EGR tube from exhaust manifold. Disconnect all wires, lines, linkage and hoses from intake manifold.

2) Remove fuel pump. Remove lower manifold bracket screw, manifold nuts and lift brackets. Remove manifold and gasket.

Installation – 1) Clean all mating surfaces of manifold and cylinder head. Install manifold, lift bracket and nuts. Do not tighten.

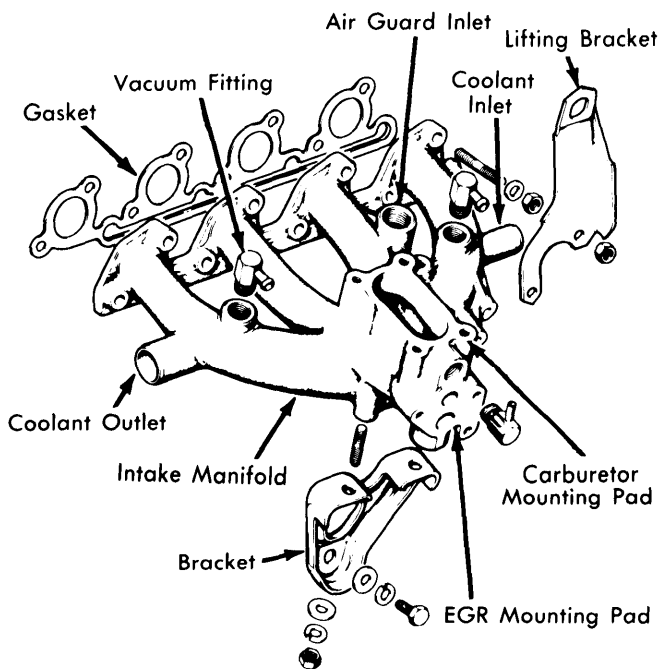

Fig. 1 Top View of Intake Manifold Showing Relationship of Manifold to Other Components

2) Connect EGR tube to exhaust manifold. Tighten intake manifold nuts to 18 ft. lbs. Install lower bracket screw and torque to 30 ft. lbs.

3) Install fuel pump using new gasket. Reverse removal procedure to complete assembly.

4) Refill cooling system, run engine until warm and check for leaks.

EXHAUST MANIFOLD

Removal – 1) Remove TAC cold air induction manifold, valve assembly and vacuum motor. Disconnect vacuum line and EGR tube. Disconnect exhaust pipe from manifold.

2) Remove exhaust manifold nuts and washers. Remove manifold and gasket.

Installation – 1) Install replacement gasket to studs on head. Install manifold and finger tighten nuts and washers.

2) Install EGR tube to manifold and tighten manifold nuts to 18 ft. lbs.

3) Reinstall exhaust pipe to manifold. Reverse removal procedure to complete installation.

CYLINDER HEAD

Removal – 1) Drain cooling system and remove air cleaner. Remove TAC vacuum motor, flexible hoses and valve assembly. Remove drive belts.

2) Disconnect cooling system hoses. Remove camshaft drive belt guard and drive belt. Remove air pump belt.

3) Remove engine fan assembly, air pump and pump bracket. Disconnect exhaust pipe from manifold. Disconnect air and heater hoses.

4) Disconnect all wires and hoses to intake and exhaust manifolds and cylinder head. Disconnect fuel line and accelerator cable.

5) Remove cylinder head cover. Remove cylinder head bolts. **NOTE** – Follow reverse order of cylinder head tightening sequence (see Fig. 2).

6) Remove cylinder head, intake and exhaust manifolds and carburetor as an assembly. **NOTE** – Do not mill or grind cylinder head.

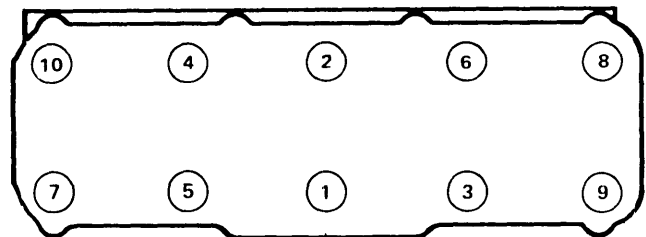

Fig. 2 Cylinder Head Tightening Sequence

Installation – 1) Install locating dowels, if removed, in cylinder head. Install new head gasket. Install cylinder head to block and tighten bolts in sequence (see Fig. 2). Torque to 65 ft. lbs.

121" 4-CYL. (Cont.)

- 2) To complete installation, reverse removal procedure.
- 3) Start engine and run for five minutes until at operating temperature. Retorque cylinder head bolts.

Cylinder Head Retorque – 1) Remove cylinder head cover. Follow cylinder head bolt tightening sequence (see Fig. 2). Loosen each bolt $\frac{1}{8}$ turn before retightening to 80 ft. lbs.

- 2) Reinstall cylinder head cover. Reverse removal procedure to complete installation.

VALVES

VALVE ARRANGEMENT

I-E-I-E-I-E-I-E (front to rear)

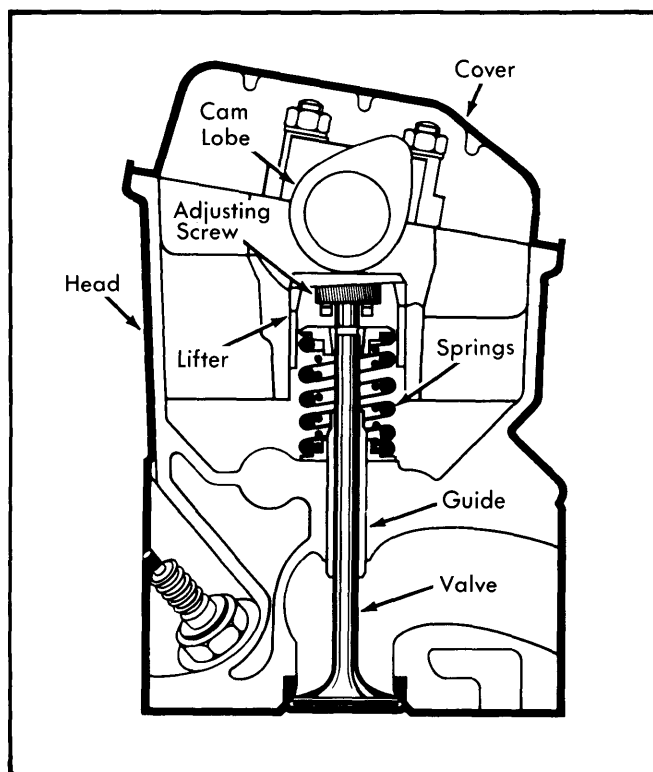

Fig. 3 Cut Away View of Installed Valve in Relation to Camshaft and Cylinder Head

VALVES

Removal – 1) With cylinder head removed, build wooden fixture as shown in Fig. 4. Mount fixture to bottom of head with $\frac{3}{8}$ X $4\frac{3}{4}$ " bolts to hold valves against seats during valve spring removal.

- 2) Remove valve locks, retainers, springs and oil seals. Remove wooden fixture and remove valves. **NOTE** – Retain valves in same order as removed for reinstallation in original location. **CAUTION** – When servicing valves, only INTAKE valves may be refaced. Intake valve face width must not exceed .1378" (3.5 mm) after refacing. If exhaust valves are damaged or worn, they must be replaced.

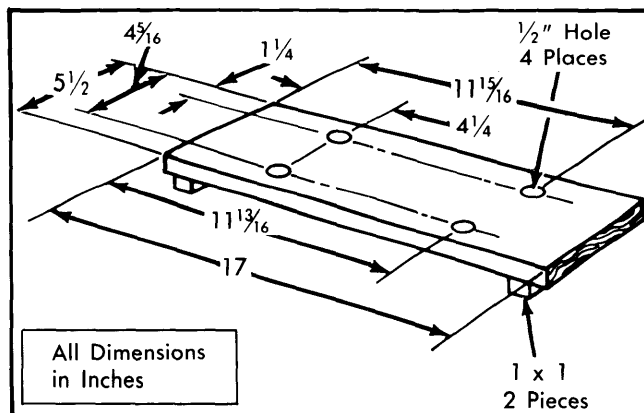

Fig. 4 Dimensions for Construction of Wooden Holding Fixture

VALVE SPRINGS

Removal – 1) Remove cylinder head cover. Remove camshaft. See Camshaft Removal in this section. Remove lifters.

- 2) Install nut loosely to one stud adjacent to each bearing. Remove TAC vacuum motor and valve assembly.

3) Remove spark plugs in cylinders to be serviced. Install suitable air line adapter to spark plug port and apply at least 90 psi to cylinder.

- 4) Using suitable valve spring compressor (J-26809), collapse spring enough to remove valve locks.

5) Remove retainer and valve spring. Extract oil seal using special tool J-26854 (or equivalent).

- 6) Place valve spring in tester. Compress spring and compare to specifications. Replace any spring not within specifications.

Installation – 1) Replace valve stem oil seals using suitable tool (J-26811). With seal installed properly, $\frac{1}{16}$ " of bevel should be visible. (See Fig. 5).

- 2) Install springs and retainers. Compress valve spring and install valve locks. Release spring tension ensuring valve locks seat properly in retainer. Reverse removal procedure to complete assembly.

VALVE STEM OIL SEALS

Valve stem oil seals are used on each valve. Seals should be replaced whenever valve service is being performed or when seals are defective.

121" 4-CYL. (Cont.)

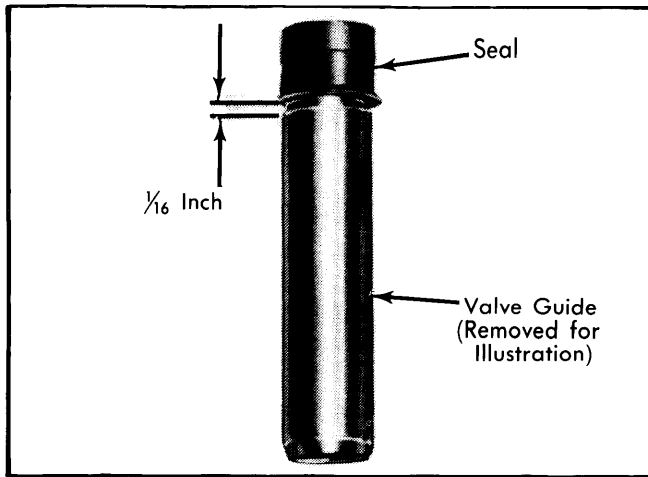

Fig. 5 Valve Stem Oil Seal Positions

ROCKER ARM ASSEMBLY

This engine contains no rocker arms or pushrods.

MECHANICAL VALVE LIFTER ASSEMBLY

Engine is equipped with mechanical valve lifters only. Inspect for signs of wear on lifter face and sides. If present, replace lifters and camshaft as necessary. Whenever camshaft and/or lifters are replaced, lubricate new parts with suitable Engine Oil Supplement. Add remainder of EOS to crankcase and leave in engine for at least 1000 miles.

MECHANICAL VALVE LIFTER ADJUSTMENT

- 1) Lifters must be adjusted any time camshaft or lifters have been removed.
- 2) Remove TAC flexible hose. Disconnect ignition wires from spark plugs. Remove cap from distributor and set aside.
- 3) Remove cylinder head cover. Rotate crankshaft to place No. 1 cylinder to TDC of power stroke.
- 4) Check clearance of exhaust valves in cylinders 1 and 3. Check clearance of intake valves in cylinders 1 and 2.

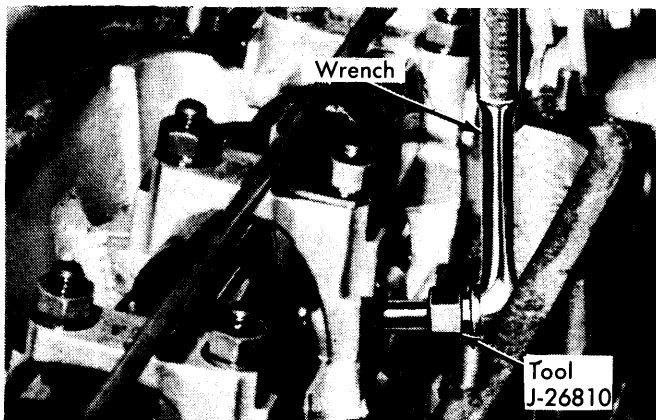

Fig. 6 Adjusting Valve Clearance

5) If not within specifications, use suitable tool (J-26810) to tighten adjusting screw. Turn screw one turn until it clicks. Each turn changes clearance by .002".

6) With clearance within specifications, check adjusting screw position in lifter. Using suitable tool (J-26860) or equivalent, ensure that outside edge of lifter falls within band on tool. If adjusting screw is turned too far into lifter to obtain proper clearance, next thicker screw must be installed. Lifter must be removed from head to replace adjusting screw.

7) Rotate crankshaft 360° to TDC position. Check clearance of exhaust valves in cylinders 2 and 4. Check clearance of intake valves in cylinders 3 and 4.

8) With all valves properly adjusted, reverse removal procedure to reassemble engine.

PISTONS, PINS & RINGS

OIL PAN

See *Oil Pan Removal* at end of ENGINE Section.

PISTON & ROD ASSEMBLY

NOTE — Connecting rods are serviced in balanced sets of four. If one rod must be replaced, all rods must be replaced.

Removal — 1) Remove cylinder head. Using suitable ridge reamer, remove any ridge or deposits from top of cylinder bore. **NOTE** — Piston should be at bottom of stroke and covered with cloth to collect cuttings.

2) Remove oil pan. Mark connecting rods and bearing caps with corresponding cylinder number and remove caps.

3) Remove connecting rod and piston assemblies from top of cylinder bore. **NOTE** — Piston and rod assemblies must be replaced in same cylinders from which removed.

Installation — 1) Position piston rings as follows: install oil control ring expander and one piece oil control ring. Install No. 2 compression ring in corresponding groove. Ensure that ring gap is not above piston pin axis. Install No. 1 compression ring with ring gap 180° from No. 2 ring gap. Markings indicate top side of rings.

2) Lightly coat pistons, rings and cylinder walls with engine oil. Install suitable ring compressor on pistons ensuring that ring gap positions do not change.

3) With connecting rod studs covered for cylinder wall and crankshaft journal protection, install piston and rod assembly.

4) Install bearing caps and bearings. Ensure number on rods and caps corresponds to cylinder. Reverse removal procedure to complete assembly.

FITTING PISTONS

Measure cylinder bore 2 $\frac{1}{16}$ " down from top of bore. Measure piston $\frac{3}{64}$ " from bottom of piston, at right angles to pin axis. Difference is piston-to-bore clearance.

121" 4-CYL. (Cont.)

PISTON PINS

Piston pins are free-floating in rods and pistons. Remove pin by removing spring clips in piston at each end of pin bore. Piston pin should slide freely through rod and piston. If pin jams in pin bore, replace pin and piston.

CRANKSHAFT & ROD BEARINGS

MAIN & CONNECTING ROD BEARINGS

Connecting Rod Bearings – 1) Ensure that rod caps are marked for cylinder identification. Remove rod caps. Use Plastigage method or micrometer to check for proper clearance. If not within specifications, new bearings must be installed. Selective fitting of bearings is not possible between rods. Undersize bearings are available as follows: .0098" (.25 mm), .0196" (.50 mm) and .0294" (.75 mm).

2) Lubricate bearing surface of each insert with engine oil and install. Reverse removal procedure to complete assembly.

Main Bearings – 1) Selective fitting of main bearings is not possible. Undersize bearings are available as follows: standard, .0098" (.25 mm), .0196" (.50 mm) and .0294" (.75 mm).

2) Remove main bearing caps one at a time. Check main bearing clearances using Plastigage method. Remove upper main bearing shell using suitable tool. Loosen all main caps when removing upper main bearings.

3) Inspect all bearings for wear and proper clearances. Replace as necessary.

4) Lubricate surface of each bearing with engine oil. Loosen main bearing caps and install main bearing upper inserts. Install lower main bearing inserts with main bearing caps.

5) Apply Loctite or equivalent to screw in bearing cap and install oil pickup tube. Reverse removal procedure to complete assembly.

THRUST BEARING ALIGNMENT

When replacing thrust bearing (located at No. 3 main bearing journal), crankshaft should be moved fore and aft to align bearing thrust faces.

REAR MAIN BEARING OIL SEAL

Removal & Installation – 1) Remove transmission. Remove pressure plate and flywheel, if equipped with manual transmission. Remove seal with suitable tool (J-26868).

2) Lightly coat tip of new seal with clean engine oil. Drive seal into position with suitable tool (J-26834), until seal bottoms. When properly installed, seal should be recessed $\frac{1}{32}$ " into block.

3) Reinstall flywheel, pressure plate and transmission.

FRONT CRANKSHAFT OIL SEAL

See *Oil Pump* in this section.

CAMSHAFT

CAMSHAFT DRIVE BELT

Removal – 1) Rotate engine until timing mark (notch) on crankshaft is pointing to zero. Camshaft sprocket timing mark should now be adjacent to pointer on cylinder head cover.

NOTE – Rotate engine by turning crankshaft. Do not turn engine by camshaft.

2) Loosen front pulley retaining screws. Remove alternator and power steering drive belts. Remove cam drive belt shield.

3) Loosen tensioner retaining screw and remove camshaft drive belt.

Installation – 1) Mount belt to crankshaft sprocket. Position belt in tensioning pulley groove and install belt to camshaft sprocket. **NOTE** – Use hands to install belt. Do not pry with tool.

2) Turn offset adjusting nut on tensioning pulley clockwise to tighten belt tension. When belt can be twisted 90° with thumb and forefinger, belt is properly tensioned. **CAUTION** – Excessive tension may cause tensioning pulley to fail.

3) Reverse removal procedure to complete installation.

CAMSHAFT

No bearing inserts are used in this engine to support camshaft. Five split bearings support camshaft. Upper bearings bolt to head and are removable. Lower bearing is integral with head and is not replaceable. No. 5 camshaft bearing determines camshaft end play.

Removal – 1) Remove TAC flexible hose, ignition wires and distributor cap. Remove alternator, camshaft drive belt guard and drive belt.

2) Remove camshaft sprocket, distributor housing and distributor. Remove cylinder head cover. Remove oil pipe above bearing caps and remove bearing caps. **NOTE** – Maintain bearing caps in order for installation in original location. Remove camshaft.

Installation – 1) Inspect for wear or rough finish on camshaft journals and bearings. Replace bearing caps, head or camshaft as needed. Inspect camshaft and lifters for wear and replace as necessary. Remove distributor drive gear and install on replacement camshaft, if required.

121" 4-CYL. (Cont.)

2) Lightly coat camshaft with engine oil and install in head. Oil bearing caps and install in original order. Install replacement seal on camshaft.

3) Reverse removal procedure for reassembly. **NOTE**— *Lifters must be adjusted for proper clearance. Start engine and adjust timing.*

CAM LOBE LIFT

1) Remove cylinder head cover and spark plugs. Install dial indicator so that plunger is directly above cam lobe. Turn crankshaft until lobe depresses lifter completely and zero indicator.

2) Rotate crankshaft until cam lobe reaches maximum lift. Compare dial indicator readings with specifications.

ENGINE OILING

Crankcase Capacity — 3½ quarts. Add 1 quart with filter change.

Oil Filter — Replace every 5000 miles or 5 months, whichever comes first.

Normal Oil Pressure — 28.5 psi @ 2000 RPM.

Pressure Regulator Valve — Set at 113 psi maximum. Located in pump body. Not adjustable.

ENGINE OILING SYSTEM

Positive displacement oil pump mounted on front end of crankshaft directs oil under pressure to passage on left side of block. Oil is then routed to inlet side of full flow oil filter and then to main oil gallery running full length of block. From main gallery, oil is directed as follows:

Crankshaft & Camshaft Bearings — Main and camshaft bearings receive oil from passages leading off main gallery.

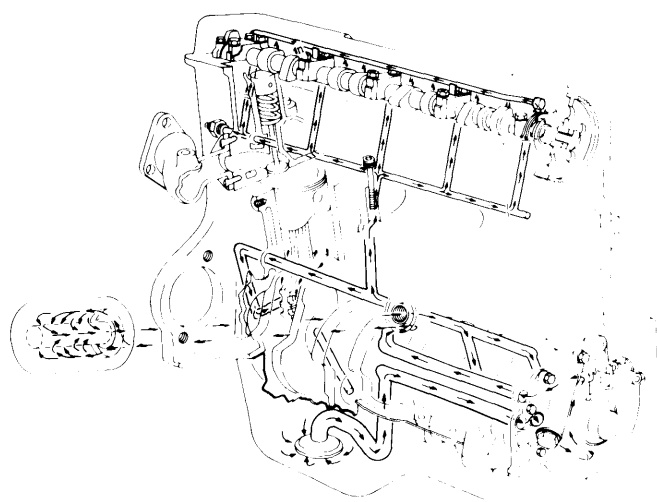

Fig. 7 Diagram for Engine Oiling Circuit

Oil is directed through drilled passages in crankshaft to rod bearings. Oil throw-off from each connecting rod lubricates cylinder walls and piston pins. No. 3 (center main) bearing is not drilled.

Camshaft and Valve Lifters — Oil gallery extends up center of engine block into head. Camshaft bearings receive oil from passage running length of head. No. 1 camshaft journal supplies oil to oil pipe above camshaft. Holes in oil pipe spray oil to camshaft lobes, lifters, fuel pump eccentric and distributor drive gear. Oil returns to pan through drains in head.

OIL PUMP

Oil pump is driven directly by crankshaft and consists of two gears, one with internal teeth and one with external teeth. Inner gear is driven by crankshaft and in turn drives outer gear. Front crankshaft oil seal is located in oil pump housing.

Oil Pump Removal — 1) Remove fan shroud. Raise car and support with safety stands. Loosen crankshaft pulley screws. Remove power steering and alternator belts.

2) Remove crankshaft pulley and attach suitable tool (J-26867) to crankshaft sprocket using all pulley screws. Remove crankshaft screw and remove sprocket.

3) Remove front oil pan screws and oil pump screws. Remove oil pump, gasket and crankshaft seal.

Installation — 1) Trim edges on gasket and install. Cut off oil pan gasket flush with block.

2) Apply suitable sealing compound to pump and oil pan and carefully tap oil pump into position. **NOTE** — *Oil pump gears must mesh correctly with lugs on crankshaft.*

3) Install new crankshaft front seal using suitable tool (J-26877) or equivalent. Install crankshaft sprocket, ensuring that pin aligns with hole. Reverse removal procedure to complete installation.

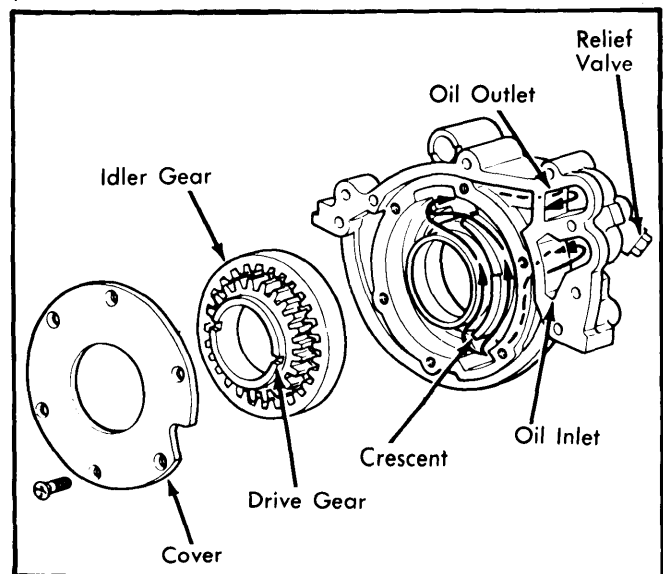

Fig. 8 Disassembled View of Oil Pump

121" 4-CYL. (Cont.)

FRONT CRANKSHAFT OIL SEAL

Removal – 1) Remove drive belts, drive belt guard and pulley. Remove crankshaft sprocket using suitable tool (J-26867) or equivalent, and pry front oil seal from oil pump recess using proper tool.

2) Clean recess prior to installation of new seal. Ensure that rim of recess is not damaged during seal removal.

Installation – 1) Lightly coat lip of new seal with engine oil. Using suitable tool (J-26877) or equivalent, drive seal into oil pump recess until seal bottoms.

2) Install crankshaft sprocket ensuring that pin in crankshaft aligns with hole in pulley. Install accessory drive pulley ensuring that pin in drive belt sprocket aligns with hole in pulley.

3) Reverse removal procedure to complete installation.

TIGHTENING SPECIFICATIONS

Application	Ft. Lbs.
Camshaft Bearing Caps	13
Camshaft Belt Tensioning Idler Screw	29
Crankshaft Sprocket Screw	181
Camshaft Rear Bearing Cap Screw	7
Camshaft Sprocket Screw	58
Connecting Rod Cap-to-Rod	41
Main Bearing Cap (Hex Head)	58
Rear Main Bearing Cap (Socket Head)	47
Cylinder Head-to-Block (cold)	65
Cylinder Head-to-Block (warm)	80
Drive Plate-to-Converter	26
Drive Plate-to-Crankshaft	65
Flywheel-to-Crankshaft	65
Intake Manifold-to-Head	18
Intake Manifold Support	30
Oil Pan Screw – Side	6
Oil Pan Screw – Front & Rear	8
Water Pump Screw – Small	7
Water Pump Screw – Large	16

ENGINE SPECIFICATIONS

GENERAL SPECIFICATIONS

Engine	Net HP At RPM	Torque (Ft. Lbs. at RPM)	Compr. Ratio	Bore	Stroke	Displ. Cu. Ins.
121" 2-Bbl.	80@5000	105@2800	8.2-1	3.41"	3.32"	121

VALVES

Engine & Valve	Head Diam.	Face Angle	Seat Angle	Seat Width	Stem Diameter	Stem Clearance	Valve Lift
121" Int.	1.490"	45°	45°	.079"	.3526-.3531"	.031"	.402"
Exh.	1.293"	45°	45°	.094"	.3522-.3528"	.039"	.382"

PISTONS, PINS, RINGS

Engine	PISTONS	PINS		RINGS		
	Clearance	Piston Fit	Rod Fit	Rings	End Gap	Side Clearance
121"	.0007-.0017"	.0001-.0003"	Full Floating	1	.010-.018"	.0012-.0024"
				2	.012-.024"	.0012-.0024"
				3	.012-.024"	.0012-.0024"

American Motors 4 Engines

121" 4-CYL. (Cont.) ENGINE SPECIFICATIONS (Cont.)

VALVE TIMING				
Engine	INTAKE		EXHAUST	
	Open (BTDC)	Close (ALDC)	Open (BLDC)	Close (ATDC)
121"	42°	78°	75°	63°

CAMSHAFT			
Engine	Journal Diam.	Clearance	Lobe Lift
121" No. 1	1.2569-1.2579"	.002-.004"	.040"①
2,3,4,5	1.021-1.022"	.002-.003"	.038"②

① - Intake ② - Exhaust

CRANKSHAFT MAIN & CONNECTING ROD BEARINGS							
Engine	MAIN BEARINGS				CONNECTING ROD BEARINGS		
	Journal Diam.	Clearance	Thrust Bearing	Crankshaft End Play	Journal Diam.	Clearance	Side Play
121"	2.5181"	.0009-.0031"	3	.0039-.0075"	1.888"	.0007-.0024"	.001-.002"

VALVE SPRINGS			
Engine	Free Length	PRESSURE (LBS.)	
		Valve Closed	Valve Open
121" Int.	1.936"①	53@1.70"①	166@1.30"①
	1.998"②	18@1.49"②	39@1.09"②
Exh.	1.936"①	53@1.70"①	160@1.32"①
	1.998"②	18@1.49"②	37@1.11"②

① - Outer Spring ② - Inner Spring