

## 425" CADILLAC V8

### IDENTIFICATION CODING

#### ENGINE IDENTIFICATION

**Engine Numbers** – Two numbers are stamped on engine block, one number is an engine unit number and is located behind left cylinder head. The other is a V.I.N. derivative number and is located behind intake manifold and is decoded as follows:

**67Q10001**

- First Digit** – Indicates Cadillac Division.
- Second Digit** – Model Year.
- Third Digit** – Plant Designation.
- Remaining Digits** – Sequence Built Number.

#### SPECIAL ENGINE MARKS

The identification letter is stamped on cylinder head face of cylinder block. The letter is located directly below cylinder bore. Single letter denotes cylinder-piston size. If double letters (AA, BB) appear on cylinder head face of block just above the cylinder bore, it indicates that this particular cylinder has been bored to .010" over the diameter indicated by a single letter in chart below.

Letter	Cyl. Size	Piston Size
A .....	4.0820-4.0824"	4.0810-4.0814"
B .....	4.0824-4.0828"	4.0814-4.0818"
C .....	4.0828-4.0832"	4.0818-4.0822"
D .....	4.0832-4.0836"	4.0822-4.0826"
E .....	4.0836-4.0840"	4.0826-4.0830"

#### ENGINE REMOVAL

See Engine Removal at end of ENGINE Section.

### CYLINDER HEAD & MANIFOLDS

#### INTAKE MANIFOLD

**Removal (Carburetor Models)** – 1) Disconnect negative battery cable. Disconnect all hoses at air cleaner and remove air cleaner. Disconnect HEI connector. Disconnect carburetor and cruise control linkage at throttle adapter plate. Disconnect spark plug wires from spark plugs on right side of engine. Disconnect two orange wires from downshift switch and one white wire from choke.

2) Remove throttle return spring and downshift switch bracket. Disconnect power brake vacuum line and vacuum modulator line from rear of carburetor on all models except Eldorado. Position brake line out of way. Disconnect double connector from compressor clutch. Disconnect vacuum hoses at rear of manifold. Disconnect fuel line at carburetor.

3) Disconnect canister purge hose at carburetor and distributor vacuum advance hose at intake manifold. Remove air conditioning compressor without disconnecting hoses, and set aside. Disconnect PCV valve from right valve cover. Disconnect automatic level control vacuum hose (if equipped). Remove manifold bolts and nuts, and remove manifold. Remove sheet metal manifold shield and gasket. Remove front and rear manifold to cylinder block rubber seals.

**Installation** – Position rubber seals over rails at front and rear of cylinder block. Tabs on gasket should be positioned in holes in rails and beveled ends of gasket tucked into slot at mating of head and rail. Use suitable sealer and position sheet metal gasket and shield on engine. **NOTE** – Holes in gasket should engage dowel pins on cylinder heads. Install manifold and tighten nuts and bolts. To complete installation, reverse removal procedure.

**Removal (Fuel Injection Models)** – 1) Disconnect negative battery cable. Remove air cleaner and crankcase filter. Disconnect throttle cable and cruise control linkage at throttle body. Disconnect cable from bracket and position out of way. On left side of engine disconnect all electrical connections. Disconnect harness from fuel rail brackets and position out of way.

2) Disconnect vacuum hoses from carburetor. **CAUTION** – Fuel in fuel system may be under pressure, system must be bled before disconnecting fuel line from fuel rail. On models without pressure relief valve in rear fuel rail, cover fuel inlet line with a shop towel while loosening clamps. Models equipped with Schrader valve in rear fuel rail do not require bleeding of system. Disconnect fuel line from fuel rail.

3) On right side of engine, disconnect all electrical connections. Disconnect harness from fuel rail brackets and position harness out of way. Remove PCV valve from valve cover. Remove spark plug cables and remove distributor cap. Remove front fuel rail. Remove air compressor with out disconnecting lines and position out of way. Remove fuel return line from pressure regulator. Remove intake manifold bolts and nuts and remove intake manifold. Remove sheet metal shield gaskets.

**Installation** – Position rubber seals over rails at front and rear of cylinder block. Tabs on gasket should be positioned in holes in rails and beveled ends of gasket tucked into slot mating of head and rail. Use suitable sealer and position sheet metal gasket and shield on engine. **NOTE** – Holes in gasket should engage dowel pins on cylinder heads. Install manifold and tighten nuts and bolts. To complete installation, reverse removal procedure.

#### CYLINDER HEAD

**Removal** – Drain cooling system and remove intake and exhaust manifolds. Remove rocker arm covers. Disconnect electrical ground connections from cylinder heads. Partially remove power steering pump if working on left cylinder head. Remove heater hose from rear of right cylinder head. Remove alternator and A.I.R. pump. Remove rocker arm assemblies (must be installed in original positions) and push rods. Remove cylinder head bolts and lift heads from block.

**NOTE** – Bottom rear bolt is trapped due to clearance. Suspend the bolt to facilitate removal.

## 425" CADILLAC V8 (Cont.)

**Installation** — **NOTE** — Bottom rear bolt must be installed and suspended prior to positioning of cylinder head. Clean all gasket surfaces and position cylinder head and gasket over dowels on block. Install ten head bolts in locations as shown in Fig. 1 and table. Tighten head bolts, starting from center of head and working toward both ends.

Bolt Location	Length
A (Bolt)	4.36" (Medium)
B (Bolt)	4.77" (Long)
C (Bolt)	3.02" (Short)
D (Bolt/stud)	4.77" (Long)

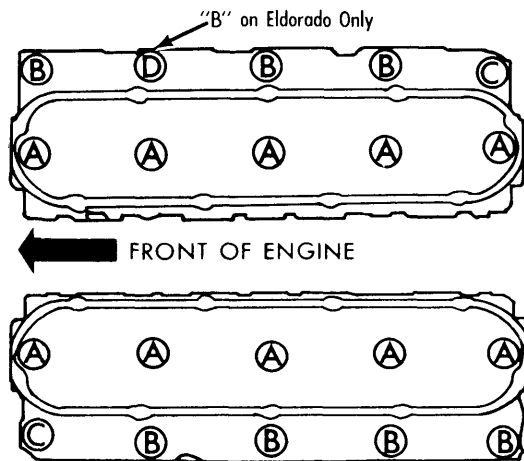

Fig. 1 Cylinder Head Bolt Location

## VALVES

## VALVE ARRANGEMENT

E-I-E-I-E-I-E-I (Right bank front to rear).  
I-E-I-E-I-E-I-E (Left bank front to rear).

## VALVE GUIDE SERVICING

If stem-to-guide clearance exceeds specifications, valve guide should be reamed to next oversize and valve with corresponding oversize stem installed. Service valves are available in standard .003", .006", and .013" oversize. Use suitable reamers to obtain correct clearance. **NOTE** — Valve guides and valves .003" oversized may be installed at factory and indicated by a "3" stamped on cylinder head gasket surface in line with oversize valve. Oversize valves are marked on valve head.

## VALVE STEM SEALS

A nylon oil shedder is used, which is part of valve spring retainer (see Fig. 2). Replace any time valve spring is removed.

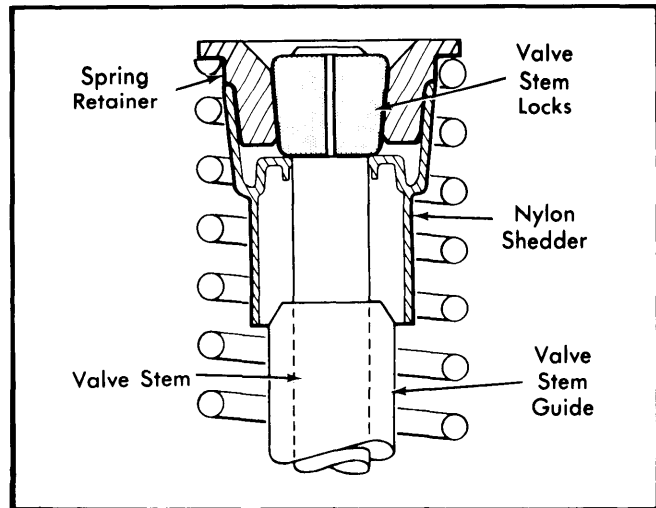

Fig. 2 Valve Spring Retainer &amp; Oil Shedder

## VALVE SPRINGS

**Removal** — Remove air cleaner, rocker arm cover, rocker arm assembly, push rods and spark plug on cylinder to be serviced. Install suitable adapter (J-22794) to spark plug port and supply air to cylinder. Install rocker arm support bolt and position suitable valve spring compressor (J-22765) over bolt. Compress valve spring, remove locks from valve stem and lift out spring retainer with nylon shedder, then remove spring.

**Installation** — Install valve spring and new retainer with nylon shedder. Use suitable valve spring compressor to compress spring and install locks.

## ROCKER ARM ASSEMBLY

Ensure that all parts are replaced in original order (see Fig. 3).

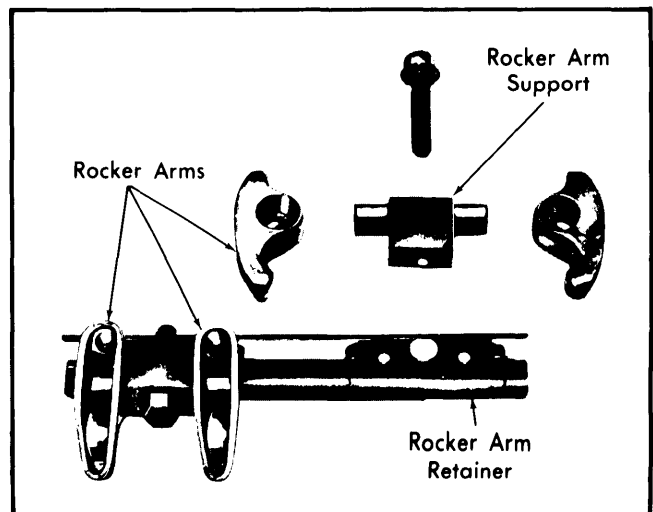

Fig. 3 Rocker Arm Assembly

## HYDRAULIC VALVE LIFTER ASSEMBLY

Valve plungers and bodies are matched sets and parts are not interchangeable. Replace any lifter found to be defective.

## 425" CADILLAC V8 (Cont.)

### HYDRAULIC VALVE LIFTER LEAKDOWN RATE CHECK

Use suitable leakdown rate tester (J-3074) to check for faulty lifters without disassembling engine. Tool uses a feeler gauge between rocker arm and valve stem which causes valve spring pressure to force oil out of lifters. When lifter has leaked down enough for valve to seat, a spring on tool which is compressed against valve spring retainer, ejects feeler gauge. Noisy lifter(s) will be those which have shortest leakdown rate. Run engine to allow lifters to fill up with oil and check lifters in following order: **NOTE** — Insert feeler gauge of tool quickly to avoid unnecessary leakdown.

1) With rotor at No. 1 firing position, check:

No. 1 Intake	No. 1 Exhaust
No. 2 Intake	No. 3 Exhaust
No. 5 Intake	No. 5 Exhaust
No. 7 Intake	No. 6 Exhaust
No. 8 Intake	No. 8 Exhaust

2) With rotor at No. 4 firing position, check:

No. 3 Intake	No. 2 Exhaust
No. 4 Intake	No. 4 Exhaust
No. 6 Intake	No. 7 Exhaust

### PISTONS, PINS & RINGS

#### OIL PAN

See Oil Pan Removal at end of ENGINE Section.

#### PISTON & ROD ASSEMBLY

**NOTE** — If working on Eldorado, remove engine from vehicle. See Engine Removal at end of ENGINE Section.

**Removal** — With cylinder heads, oil pan and oil pickup tube assembly removed, use a ridge reamer to remove any ridge or deposits on upper end of cylinder bore.

**NOTE** — Piston must be at bottom of stroke and covered with cloth to collect cuttings.

Remove rod cap and install rubber hose over connecting rod studs, to protect crankshaft. Push piston and rod assembly out the top of cylinder block.

**Installation** — Lightly coat pistons, rings and cylinder walls with engine oil. Ensure compression rings are installed with dimple on ring facing top of piston. Install suitable ring compressor on piston and connecting rod stud guides. Install piston and rod assembly in cylinder bore with notch on top of piston towards front of engine (letter "R" on piston toward rear). Guide connecting rod onto crankshaft journal while tapping piston head with hammer handle to seat connecting rod against crankshaft. Remove tool from connecting rod studs and install mating rod cap ensuring that numbered side of cap is on same side as numbered side of rod. **NOTE** — Numbered sides of connecting rods on Nos. 1,3,5,7 rods must be on right side of engine and Nos. 2,4,6,8 on left side of engine. Install rod cap nuts and tighten.

#### FITTING PISTONS

Measure pistons  $\frac{3}{16}$ " below upper cross slot or  $\frac{1}{4}$ " below oil ring groove. Measure cylinders  $1\frac{1}{8}$ " from top of bore, crosswise to cylinder block.

#### PISTON PINS

**Removal** — Using a suitable removal tool assembly (J-25270-90), position piston and connecting rod assembly on tool support with side of piston marked "R" upward. Press pin from assembly.

**NOTE** — Keep piston pins in order or marked to ensure that they are installed in original pistons and connecting rods.

**Installation** — Lubricate piston pin and pin holes in piston with engine oil. Position connecting rod in its respective piston so when assembly is installed in engine, side of piston stamped with "R" is toward rear of engine and number on lower end of rod is down. Press pin until it bottoms on spacer in support (see Fig. 4).

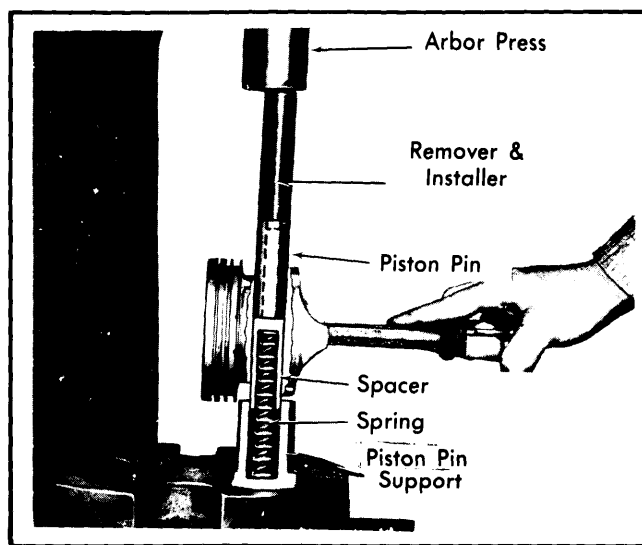

Fig. 4 Piston Pin Installation

### CRANKSHAFT & ROD BEARINGS

#### MAIN & CONNECTING ROD BEARINGS

**NOTE** — Following procedures are performed with oil pan and oil pickup tube assembly removed.

**Connecting Rod Bearings** — After ensuring rod caps are marked for cylinder identification, remove rod caps. Use Plastigage method for checking proper bearing clearances. If clearance is not within specifications, replace bearings. If new bearings (standard bearings only size available) do not bring clearances within specifications, crankshaft must be replaced.

**NOTE** — When installing bearings, tangs on bearings must match notches in rod and cap.

**Main Bearings** — 1) Check main bearing clearances one at a time using Plastigage method. If bearings are being checked with engine in vehicle, crankshaft must be supported to take up clearance between upper bearing half and crankshaft (place strip of .005" brass shim stock between lower bearing half and crankshaft bearing journal in bearing caps adjacent to bearing being checked). If clearance is not within specifications, replace bearings. If new bearings (standard bearings only size available) do not bring clearances within specifications, crankshaft must be replaced.

## 425" CADILLAC V8 (Cont.)

2) No. 1 upper and lower bearings are interchangeable and No. 2 and 4 upper bearings are interchangeable. No. 2 and 4 lower bearings are interchangeable. No. 3 and 5 bearings are not interchangeable and must be reinstalled in original positions.

3) To change main bearing upper halves, insert suitable tool in oil hole of crankshaft journal and rotate crankshaft clockwise to roll bearing from engine. Oil new upper bearing and with locating tang in correct position, rotate crankshaft counterclockwise to position bearing (with suitable tool in oil hole). **CAUTION** — Main bearing caps must be installed in same position they were removed from and facing same direction.

**THRUST BEARING ALIGNMENT**

With all main bearing cap bolts finger tight, tap crankshaft forward, then rearward several times to align (No. 3) thrust bearings. Tighten all main bearing cap bolts.

**REAR MAIN BEARING OIL SEAL**

**Removal** — Remove engine oil pan. Remove rear main bearing cap and discard lower seal half removed from bearing cap. Rotate upper seal half by pushing on one end with sharp object and remove seal half from cylinder block. Inspect grooves in bearing cap and cylinder block to ensure they are clean, dry and free from burrs.

**Installation** — 1) **NOTE** — Two seal halves are identical and pre-lubricated with a film of wax for break-in. Do not remove or damage this film. To install lower half of seal in bearing cap, slide end of seal into position at one end of cap and place suitable tool (see Fig. 5) made from shim stock in groove at other end of bearing cap. Lip of seal must face front of engine. Install seal half using tool as a "shoehorn" ensuring seal is flush on each side.

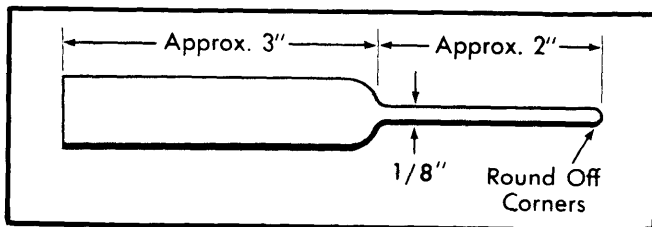
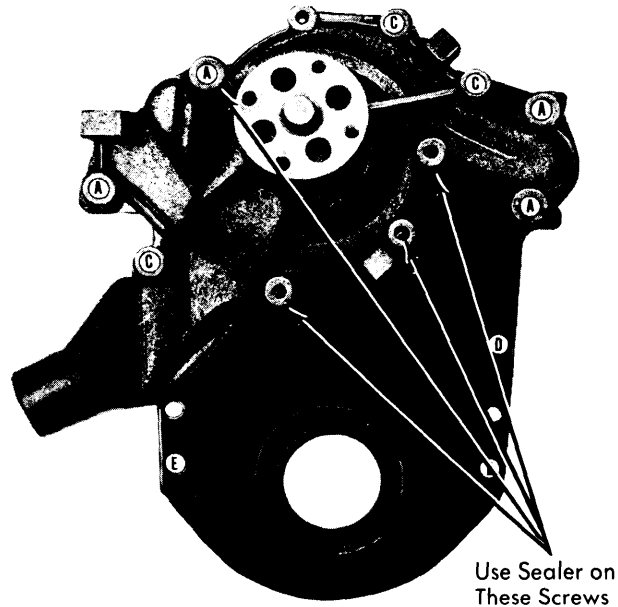

Fig. 5 Oil Seal Installing Tool

2) To install upper half of seal in cylinder block, position tool in groove of block. Lubricate seal with Lubriplate and start into groove in block with lip facing forward. Rotate seal into position using care not to distort it. Ensure that seal ends are flush at split line, install main bearing cap and tighten cap bolts.

**CAMSHAFT****ENGINE FRONT COVER**

**Removal** — **NOTE** — On Eldorado models, engine must be removed from vehicle. Remove crankshaft pulley and spacer. Loosen starter enough to gain access to oil pan bolts. Loosen oil pan bolts and lower front of oil pan. Remove lower radiator hose from water pump. Remove bolts securing front cover and lift off front cover and water pump as an assembly.



Key	(No.)	Size	Torque
A	(4)	3/8-16 x 1-3/8	22 Foot-Pounds
C	(3)	5/16-18 x 1-1/4	10 Foot-Pounds
D	(1)	5/16-18 x 5/8	10 Foot-Pounds
E	(2)	3/8-16 x 5/8	22 Foot-Pounds

Fig. 6 Engine Front Cover Bolt Locations & Torque Specifications

**Installation** — Clean all gasket surfaces and install new front cover gasket over locating dowels on cylinder block, using a small amount of sealer to hold gasket in place. Install front cover and water pump assembly over end of crankshaft, lining up dowel holes in cover with dowels on cylinder block. Install bolts and tighten (see Fig. 6 and table for location of bolts and specifications).

**FRONT COVER OIL SEAL**

**Removal & Installation** — Remove crankshaft pulley hub and spacer. Using a thin-bladed screwdriver, pry out front cover oil seal and discard. Lubricate new oil seal using wheel bearing grease. Position seal on end of crankshaft with spring side toward engine. Using suitable tool (J-22770) drive seal into front cover until it bottoms.

## 425" CADILLAC V8 (Cont.)

### CAMSHAFT

**Removal** — **NOTE** — On Eldorado models, engine must be removed from vehicle. Remove radiator, front cover, ignition distributor, oil pump and fuel pump. Remove oil slinger from crankshaft. Remove bolt securing fuel pump eccentric to camshaft and remove eccentric. Remove bolts securing camshaft sprocket to camshaft and remove camshaft sprocket with chain attached. Remove valve lifters and slide camshaft forward carefully until free from engine.

**Installation** — Apply a thin coat of rear axle lubricant to all camshaft lobes and bearing journals, and guide camshaft carefully into cylinder block. Reverse removal procedures while noting the following: Extreme care must be exercised to avoid nicking or scratching camshaft bearings. Install camshaft sprocket in timing chain with timing mark toward front. Place chain over crankshaft sprocket and line up timing marks on both sprockets (see Fig. 7). Index hole in camshaft must line up with index hole in sprocket.

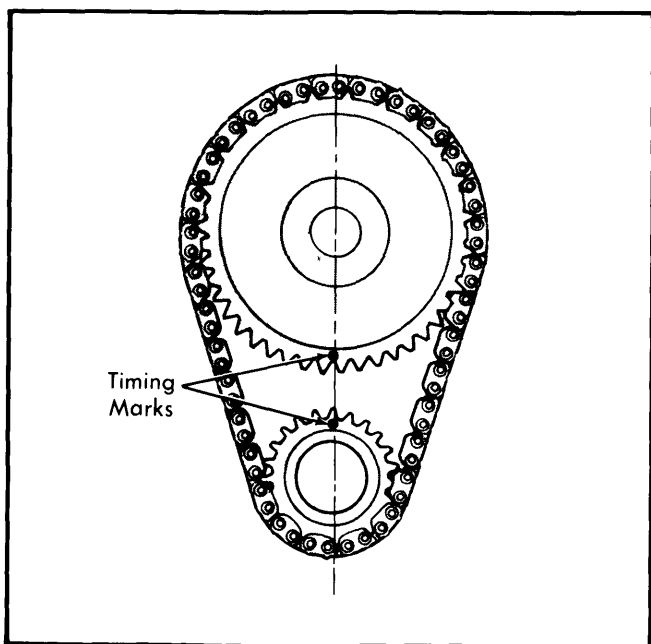

Fig. 7 Timing Chain Sprocket Alignment

### CAMSHAFT BEARINGS

**Removal** — Remove camshaft and use suitable tool (J-21054) to remove bearings. Drive No. 1 bearing through rear face of bearing bore and remove from tool. Remove remaining bearings in same manner. **NOTE** — When removing No. 5 bearing, drive out rear plug along with bearing.

**Installation** — Install new plug in rear of No. 5 bearing bore and seal plug with suitable sealer. Scribe a reference mark on front face of each bore to indicate position of center oil passage. Using suitable tool install bearings, lining up oil hole in bearing with scribe mark on front face of bore.

### ENGINE OILING

**Crankcase Capacity** — 4 quarts except Eldorado which is 5 quarts. Add one quart with filter change.

**Oil Filter** — Change at first oil change and every second oil change after that.

**Normal Oil Pressure** — 35-40 psi at 30 MPH. Average pressure at idle is 10 psi.

**Pressure Regulator Valve** — Not adjustable.

### ENGINE OILING SYSTEM

See *Engine Oiling System Illustration*. Right longitudinal header is fed through angular passage from oil filter and pump. Oil crosses to left longitudinal header through intersecting vertical passages above No. 2 camshaft bearing, continues up vertical header to oil pressure signal switch.

**Crankshaft, Camshaft & Connecting Rods** — Main bearings No. 2, 3 and 4 are lubricated from right longitudinal header through holes drilled in block. Main bearings No. 1 and 5 are lubricated in same manner from left header. Camshaft bearings are lubricated from corresponding main bearings through holes in block. Connecting rod bearings are lubricated from adjacent main bearing through holes in crankshaft.

**Lifters, Rocker Arms, Pistons & Pins** — Longitudinal headers feed hydraulic valve lifters under pressure through drilled passages. From lifters, oil flows through hollow push rods to rocker arms, controlled by metering disc in lifter. Oil comes through feed hole in rocker arm, flows onto arm, lubricating rocker arm pivot points, push rod tips, and valve tips. Pistons, pins and cylinder walls are lubricated by oil splashed up from crankcase. Oil drains from cylinder heads into valve lifter compartment, returns to crankcase through hole on bottom of compartment.

### OIL PUMP

Oil pump is mounted on right side near front of engine. Remove oil filter. Remove five bolts securing pump to engine, leaving bolt nearest pressure regulator until last. Clean and inspect all parts (see Oil Pump Specifications). Before reinstalling pump, pack with petrolatum.

### Oil Pump Specifications

Gear Backlash .....	.001-.013"
Gear-to-Body Clearance.....	⓪ .001-.004"
Reg. Valve-to-Bore Clearance.....	⓪ .0020-.0035"
Reg. Valve Spring	
Free Length .....	.257-.269"
Pressure @ 1.460" .....	9.3-10.5 Lbs.

⓪ — Wear limit .005".

# General Motors V8 Engines

## 425" CADILLAC V8 (Cont.)

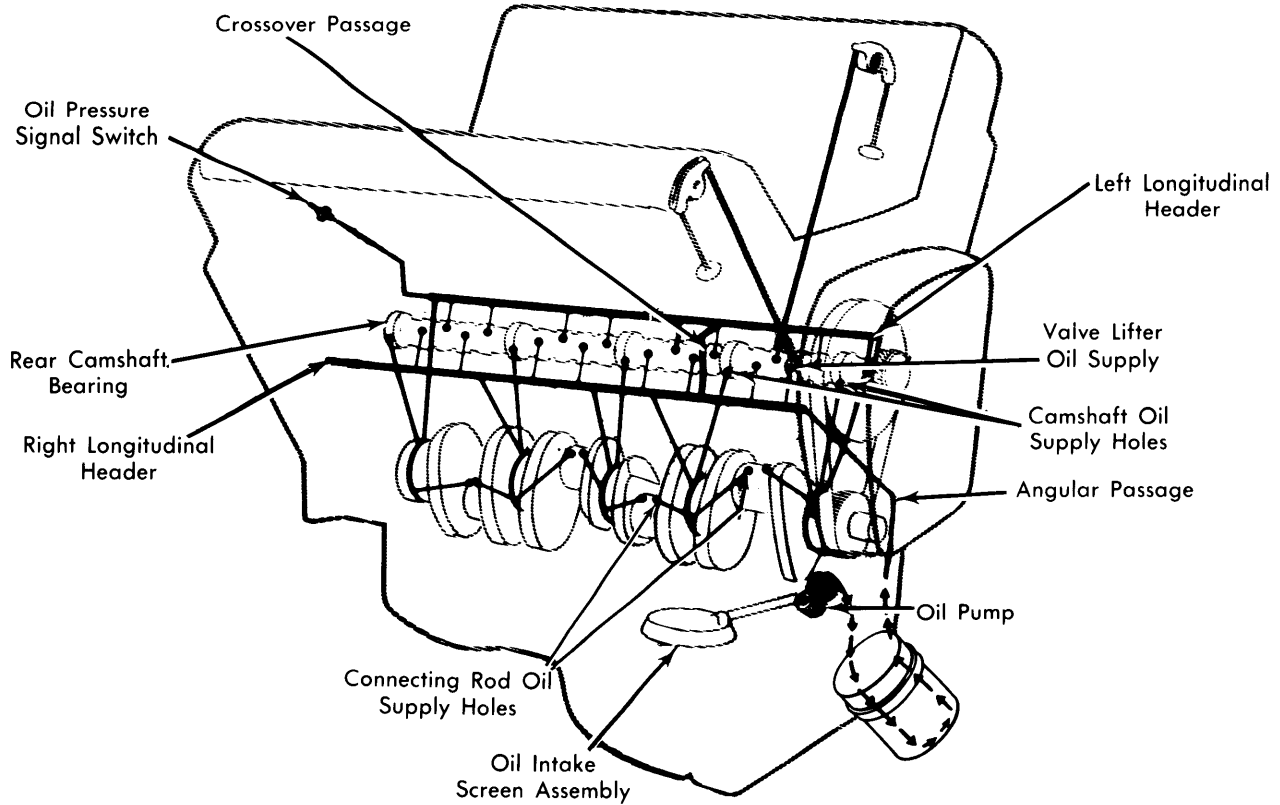

Fig. 8 Engine Oiling System

### ENGINE SPECIFICATIONS

GENERAL SPECIFICATIONS						
Engine	Net HP At RPM	Torque (Ft. Lbs. at RPM)	Compr. Ratio	Bore	Stroke	Displ. Cu. Ins.
425" (Carb. Models)	180 @4000	320 @2000	8.2:1	4.082"	4.060"	425"
425" (EFI Models)	195 @3800	320 @2400	8.2:1	4.082"	4.060"	425"

VALVES							
Engine & Valve	Head Diam.	Face Angle	Seat Angle	Seat Width	Stem Diameter	Stem Clearance	Valve Lift
425" Int.	2.000"	44°	45°	1/16"	.3413-.3420"	.001-.0027"	.457"
425" Exh.	1.625"	44°	45°	1/16"	.3413-.3420"	.001-.0027"	.473"

VALVE SPRINGS			
Engine	Free Length	PRESSURE (LBS.)	
		Valve Closed	Valve Open
425" Int. & Exh.	2.250"	60-65 @ 1.946"	155-165 @ 1.496"

VALVE TIMING				
Engine	INTAKE		EXHAUST	
	Open (BTDC)	Close (ALDC)	Open (BLDC)	Close (ATDC)
425"	21°	111°	73°	55°

# General Motors V8 Engines

## 425" CADILLAC V8 (Cont.)

### ENGINE SPECIFICATIONS (Cont.)

PISTONS, PINS, RINGS						
Engine	PISTONS	PINS			RINGS	
	Clearance	Piston Fit	Rod Fit	Rings	End Gap	Side Clearance
425"	.006-.0014"	.0002-.0004"	Press Fit	Comp. Oil	.013-.023" .015-.055"	.0017-.004" None

CRANKSHAFT MAIN & CONNECTING ROD BEARINGS							
Engine	MAIN BEARINGS				CONNECTING ROD BEARINGS		
	Journal Diam.	Clearance	Thrust Bearing	Crankshaft End Play	Journal Diam.	Clearance	① Side Play
425"	3.250"	② .0001-.0026"	No. 3	③ .002-.012"	2.500"	④ .0005-.0028"	.008-.020"

- ① - Total, 2 rods.
- ③ - Wear limit .015"
- ② - Wear limit .0045"
- ④ - Wear limit .0035"

CAMSHAFT			
Engine	Journal Diam.	Clearance	Lobe Lift
425"	.....	.001-.0022"	Int. .266" Exh. .275"

TIGHTENING SPECIFICATIONS	
Application	Ft. Lbs.
Camshaft Sprocket .....	18
Connecting Rod .....	40
Cylinder Head .....	95
Distributor Clamp .....	15
Exhaust Manifold .....	② 35
Flywheel-to-Converter .....	30
Flywheel-to-Crankshaft .....	75
Front Cover .....	①
Fuel Pump .....	12
Intake Manifold .....	30
Main Bearing .....	90
Oil Pan .....	10
Oil Pump .....	15
Rocker Arm Support Bolt .....	70
Thermostat Housing .....	10
Transmission Housing-to-Block .....	35
Water Pump .....	①

① - See Fig. 6.  
② - Torque short screw to 12 Ft. Lbs.